



ROCADA MED

MANUFACTURER & EXPORTER



MANUFACTURERS AND EXPORTER OF SINGLE USE & USABLE
SURGICAL INSTRUMENTS SETS / KITS / PACKS



SURGICAL
INSTRUMENTS
CATALOGUE

SURGICAL INSTRUMENTS



No. 3
13,0 cm, 5"
003-003-00



No. 3
13,0 cm, 5"
003-003-01



No. 3L
21,0 cm, 8¼"
003-003-02



No. 7
16,5 cm, 6½"
003-007-00



No. 7K
13,0 cm, 5"
003-007-01

Sterile Skalpellslingen, Skalpellsgriffe
Sterile Scalpel Blades, Scalpel Handles
Hojas de bisturíes estériles, Mangos de bisturíes
Lame per bisturi sterili, Manici per bisturi

ROCADA MED
MANUFACTURER & EXPORTER

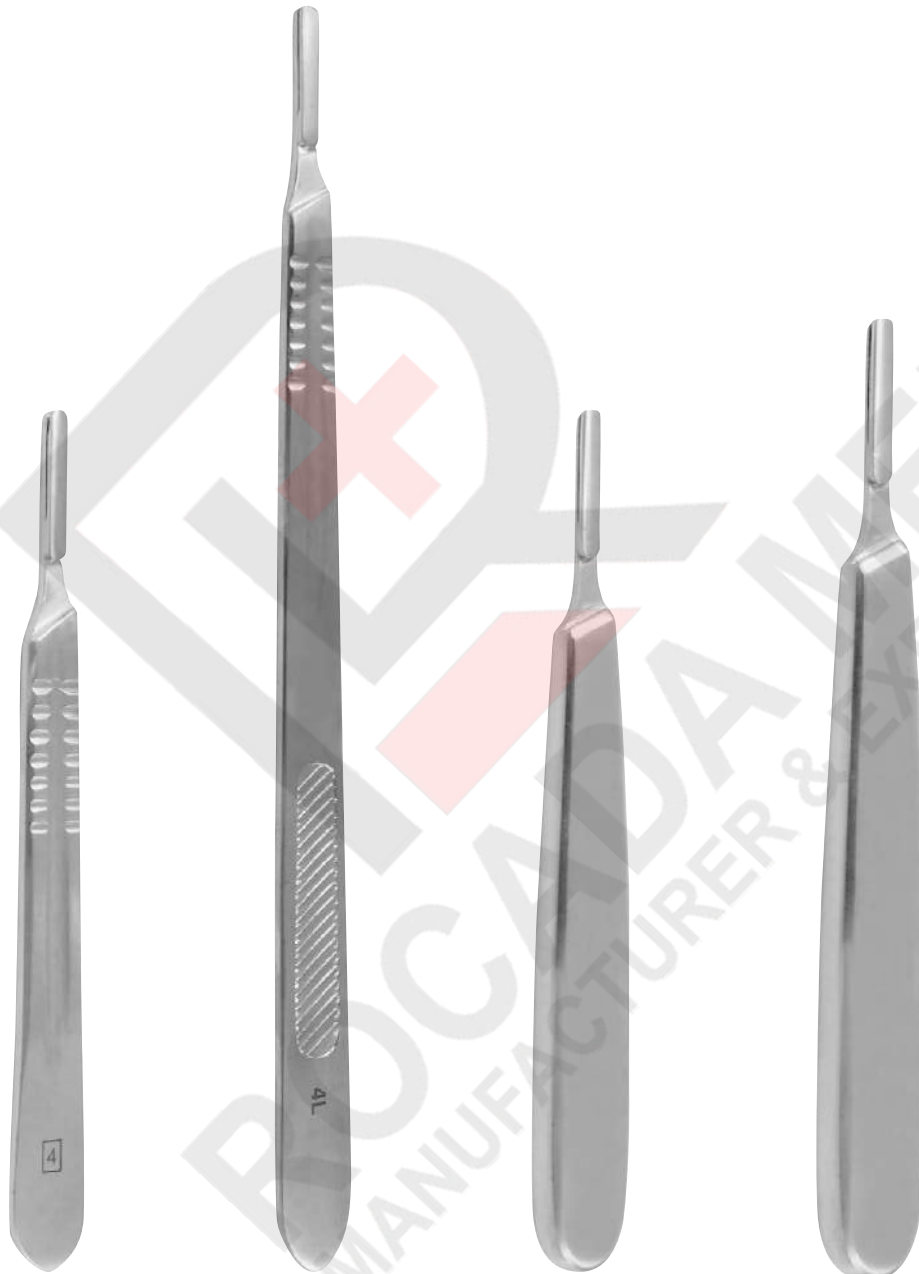

No. 4
13,5 cm, 5 / $\frac{3}{8}$
003-004-00

No. 4L
21,0 cm, 8 / $\frac{3}{8}$
003-004-01

No. 8
13,5 cm, 5 / $\frac{3}{8}$
003-008-00

No. 9
14,5 cm, 5 $\frac{1}{4}$ "
003-009-00

SURGICAL INSTRUMENTS

SURGICAL INSTRUMENTS



Fig. 10
003-050-10



Fig. 11
003-050-11



Fig. 11s
003-050-11S



Fig. 12
003-050-12



Fig. 12d
003-050-12D



Fig. 13
003-050-13



Fig. 15
003-050-15



Fig. 15c
003-050-15C



Fig. 18
003-050-18



Fig. 19
003-050-19



Fig. 20
003-050-20



Fig. 21
003-050-21



Fig. 22
003-050-22



Fig. 23
003-050-23



Fig. 24
003-050-24

SURGICAL INSTRUMENTS

SURGICAL INSTRUMENTS



OPERATION
17,0 cm, 6¼"



Fig. 10	003-060-10
Fig. 12	003-060-12
Fig. 14	003-060-14
Fig. 16	003-060-16
Fig. 18	003-060-18



COLLIN
16,0 cm, 6¼"



Fig. 1	003-066-01
Fig. 2	003-066-02
Fig. 3	003-066-03



Fig. 4	003-066-04
Fig. 5	003-066-05
Fig. 6	003-066-06



Fig. 1 003-070-01
Fig. 2 003-070-02
Fig. 3 003-070-03
Fig. 4 003-070-04
Fig. 5 003-070-05



Fig. 1 003-076-01
Fig. 2 003-076-02
Fig. 3 003-076-03
Fig. 4 003-076-04
Fig. 5 003-076-05



Fig. 15 003-078-15



DISSECTING
17,0 cm, 6¾"



Fig. 6 003-070-06
Fig. 7 003-070-07
Fig. 8 003-070-08
Fig. 9 003-070-09
Fig. 10 003-070-10



DIEFFENBACH
16,0 cm, 6¼"



Fig. 6 003-076-06
Fig. 7 003-076-07
Fig. 8 003-076-08
Fig. 9 003-076-09



Fig. 16 003-078-16

SURGICAL INSTRUMENTS

SURGICAL INSTRUMENTS

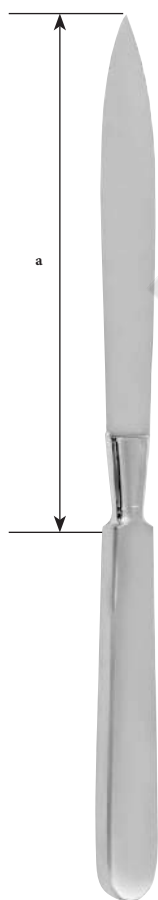

COLLIN

a	
13,0 cm, 5"	003-080-13
16,0 cm, 6 1/4"	003-080-16
19,0 cm, 7 1/2"	003-080-19
22,0 cm, 8 5/8"	003-080-22
28,0 cm, 11"	003-080-28

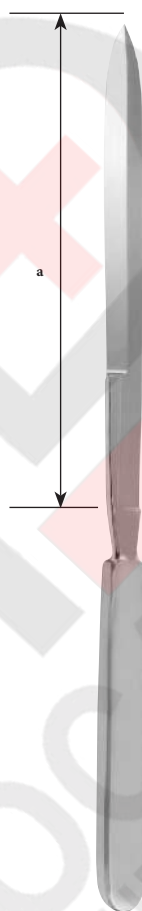

CATLIN

A	
16,0 cm, 6 1/4"	003-082-16
19,0 cm, 7 1/2"	003-082-19
22,0 cm, 8 5/8"	003-082-22



LISTON

A	
17,0 cm, 6 3/4"	003-250-17
20,0 cm, 8"	003-250-20
22,0 cm, 8 5/8"	003-250-22

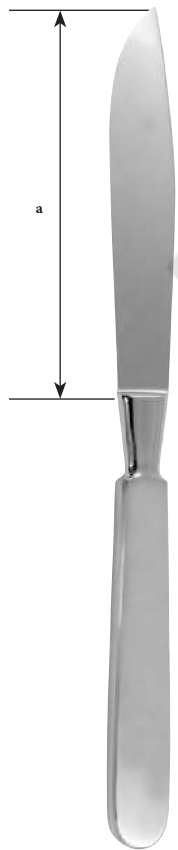

LANGENBECK
 003-280-12

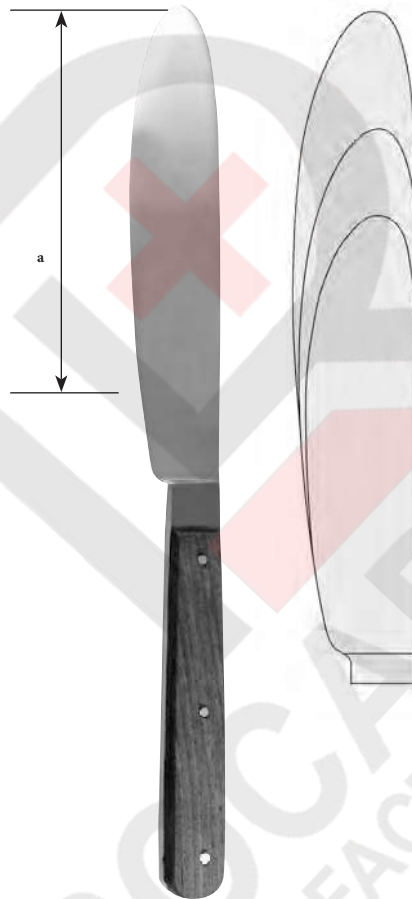

WALB

A		
11,0 cm, 4	$\frac{1}{2}$ "	003-150-11
14,0 cm, 5	$\frac{1}{2}$ "	003-150-14
17,0 cm, 6	$\frac{3}{4}$ "	003-150-17

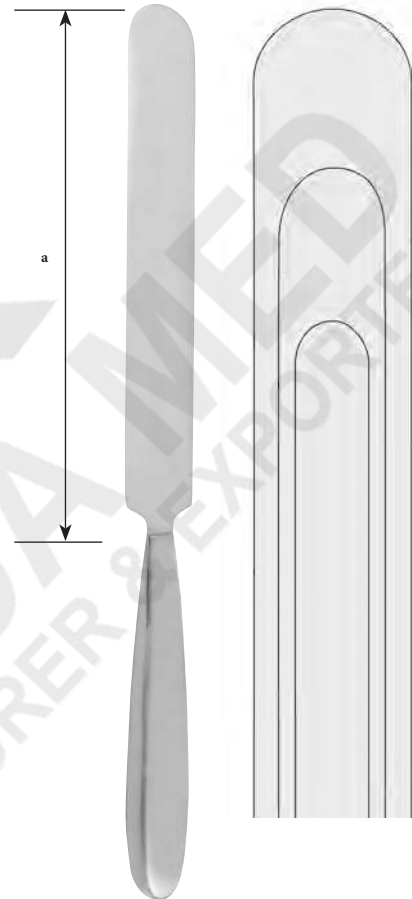

VIRCHOW

A		
16,0 cm, 6	$\frac{1}{4}$ "	003-180-16
20,0 cm, 8"		003-180-20
24,0 cm, 9	$\frac{1}{2}$ "	003-180-24

SURGICAL INSTRUMENTS

SURGICAL INSTRUMENTS



LANGENBECK
18,0 cm, 7"
003-105-55



mit Schaber
with raspatory
con periostótomo
con raschiatoio

CARTILAGE
17,5 cm, 6 / $\frac{5}{8}$
003-110-65

Haut-Spannplatten
Skin straightening plate
Placa para extender la piel
Placca per stendere la pelle



003-422-30

003-401-19
Ersatzklinge
Spare blade
Hoja de repuesto
Lama di ricambio



SILVER
19 cm, 7 1/2"
003-400-19

003-411-30
Ersatzklinge
Spare blade
Hoja de repuesto
Lama di ricambio



BRAITHWAITE
30,0 cm, 12"
003-410-30

003-413-35
Ersatzklinge
Spare blade
Hoja de repuesto
Lama di ricambio



HUMBY
35,0 cm, 14"
003-412-35

003-421-30
Ersatzklinge
Spare blade
Hoja de repuesto
Lama di ricambio



SCHINK
30,0 cm, 12"
003-420-30

SURGICAL INSTRUMENTS

SURGICAL INSTRUMENTS

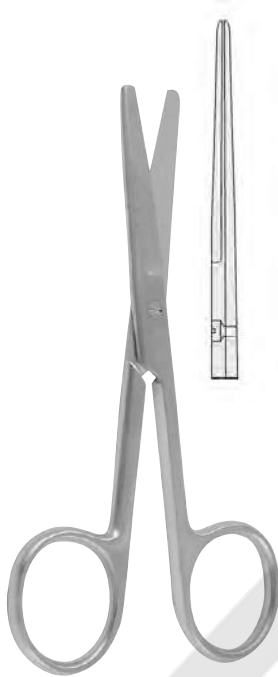

STANDARD		
10,5 cm, 4	1/4"	010-000-10
11,5 cm, 4	1/2"	010-000-11
13,0 cm, 5"		010-000-13
14,5 cm, 5	3/4"	010-000-14
15,5 cm, 6"		010-000-15
16,5 cm, 6	1/2"	010-000-16
17,5 cm, 6	5/8"	010-000-17
18,5 cm, 7	1/4"	010-000-18
20,0 cm, 8"		010-000-20

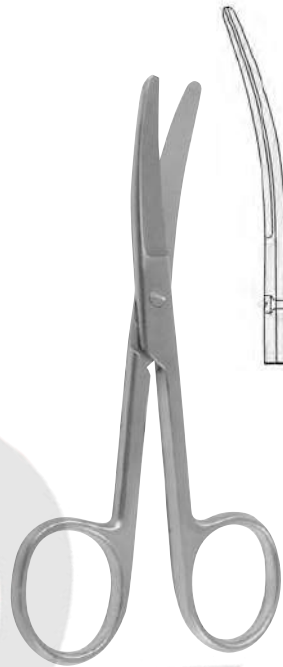

STANDARD		
10,5 cm, 4	1/4"	010-001-10
11,5 cm, 4	1/2"	010-001-11
13,0 cm, 5"		010-001-13
14,5 cm, 5	3/4"	010-001-14
15,5 cm, 6"		010-001-15
16,5 cm, 6	1/2"	010-001-16
17,5 cm, 6	5/8"	010-001-17
18,5 cm, 7	1/4"	010-001-18
20,0 cm, 8"		010-001-20



STANDARD		
10,5 cm, 4	1/4"	010-002-10
11,5 cm, 4	1/2"	010-002-11
13,0 cm, 5"		010-002-13
14,5 cm, 5	3/4"	010-002-14
15,5 cm, 6"		010-002-15
16,5 cm, 6	1/2"	010-002-16
17,5 cm, 6	5/8"	010-002-17
18,5 cm, 7	1/4"	010-002-18
20,0 cm, 8"		010-002-20

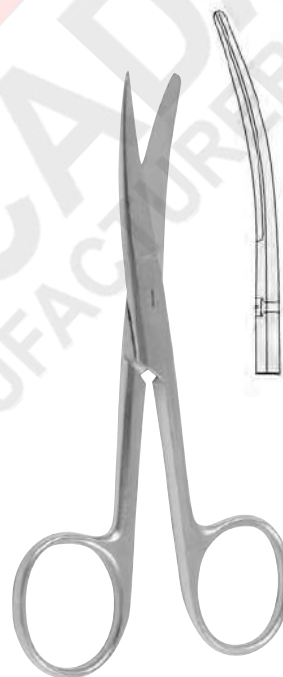

STANDARD		
10,5 cm, 4	1/4"	010-003-10
11,5 cm, 4	1/2"	010-003-11
13,0 cm, 5"		010-003-13
14,5 cm, 5	3/4"	010-003-14
15,5 cm, 6"		010-003-15
16,5 cm, 6	1/2"	010-003-16
17,5 cm, 6	5/8"	010-003-17
18,5 cm, 7	1/4"	010-003-18
20,0 cm, 8"		010-003-20

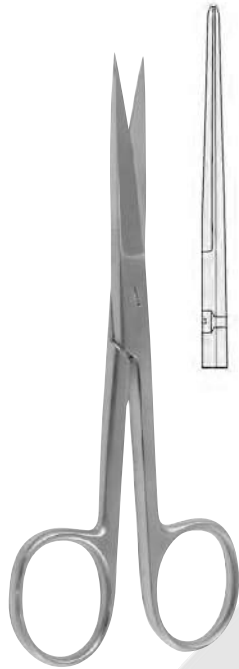

STANDARD		
10,5 cm, 4	1/4"	010-004-10
11,5 cm, 4	1/2"	010-004-11
13,0 cm, 5"		010-004-13
14,5 cm, 5	3/4"	010-004-14
15,5 cm, 6"		010-004-15
16,5 cm, 6	1/2"	010-004-16
17,5 cm, 6	5/8"	010-004-17
18,5 cm, 7	1/4"	010-004-18
20,0 cm, 8"		010-004-20

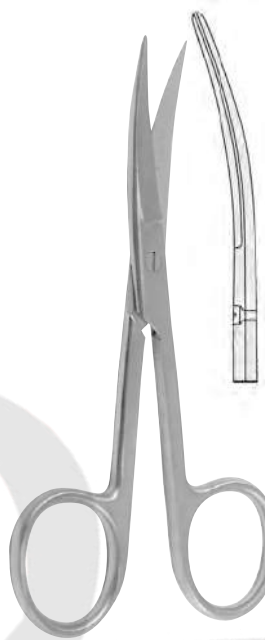

STANDARD		
10,5 cm, 4	1/4"	010-005-10
11,5 cm, 4	1/2"	010-005-11
13,0 cm, 5"		010-005-13
14,5 cm, 5	3/4"	010-005-14
15,5 cm, 6"		010-005-15
16,5 cm, 6	1/2"	010-005-16
17,5 cm, 6	5/8"	010-005-17
18,5 cm, 7	1/4"	010-005-18
20,0 cm, 8"		010-005-20



DEAVER		
12,0 cm, 4	3/4"	010-050-12
13,0 cm, 5"		010-050-13
14,5 cm, 5	3/4"	010-050-14

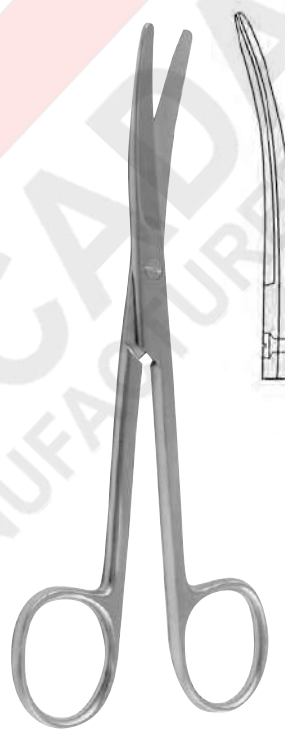

DEAVER		
12,0 cm, 4	3/4"	010-051-12
13,0 cm, 5"		010-051-13
14,5 cm, 5	3/4"	010-051-14

SURGICAL INSTRUMENTS

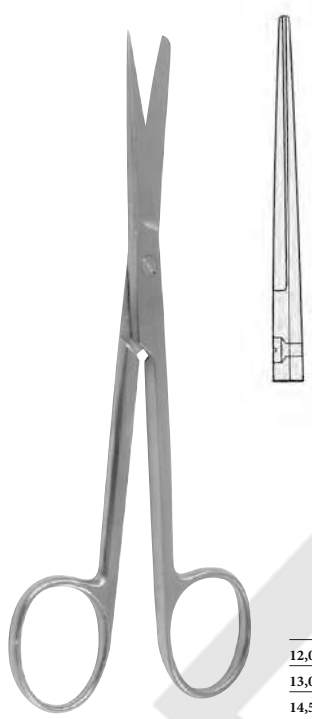

DEAVER			
12,0 cm, 4	$\frac{3}{4}$ "	010-052-12	
13,0 cm, 5"		010-052-13	
14,5 cm, 5	$\frac{3}{4}$ "	010-052-14	

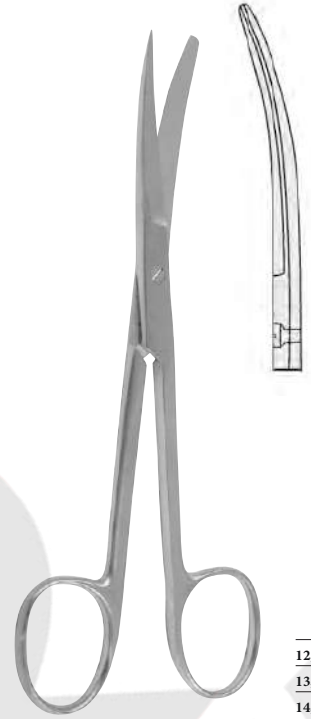

DEAVER			
12,0 cm, 4	$\frac{3}{4}$ "	010-053-12	
13,0 cm, 5"		010-053-13	
14,5 cm, 5	$\frac{3}{4}$ "	010-053-14	

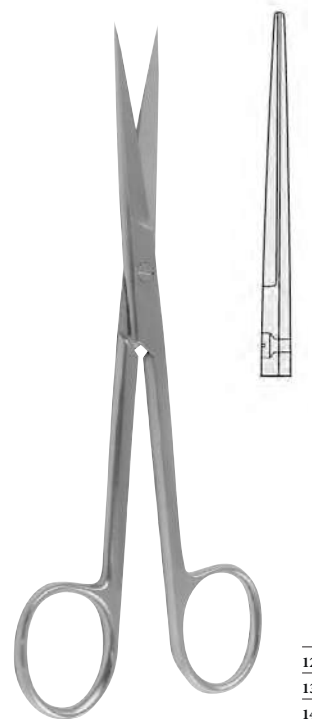

DEAVER			
12,0 cm, 4	$\frac{3}{4}$ "	010-054-12	
13,0 cm, 5"		010-054-13	
14,5 cm, 5	$\frac{3}{4}$ "	010-054-14	

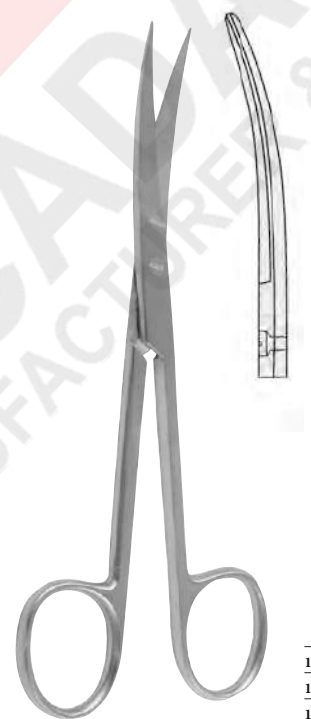

DEAVER			
12,0 cm, 4	$\frac{3}{4}$ "	010-055-12	
13,0 cm, 5"		010-055-13	
14,5 cm, 5	$\frac{3}{4}$ "	010-055-14	

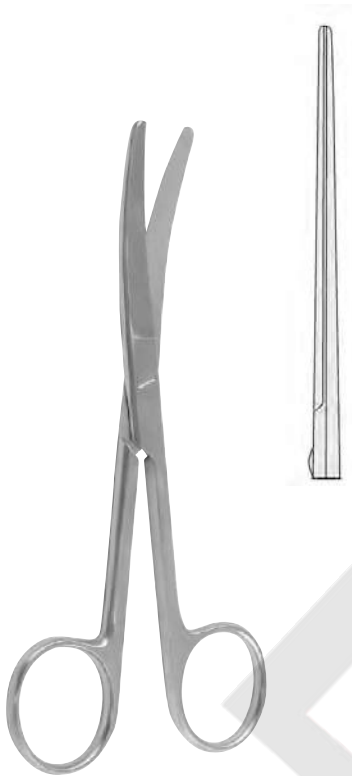

GRAZIL

13,0 cm, 5"	010-070-13
14,5 cm, 5 ³ / ₄ "	010-070-14

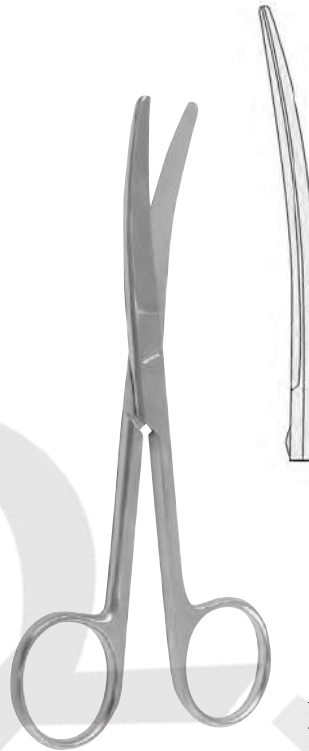

GRAZIL

13,0 cm, 5"	010-071-13
14,5 cm, 5 ³ / ₄ "	010-071-14

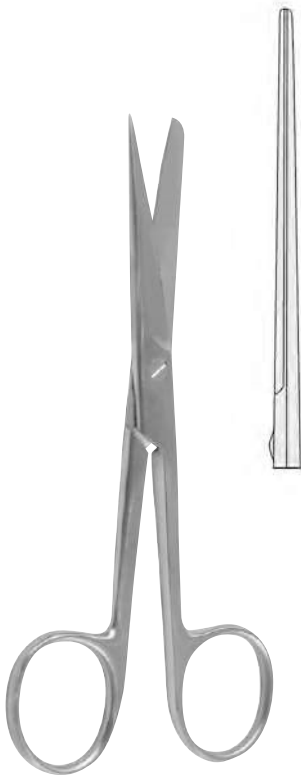

GRAZIL

13,0 cm, 5"	010-072-13
14,5 cm, 5 ³ / ₄ "	010-072-14

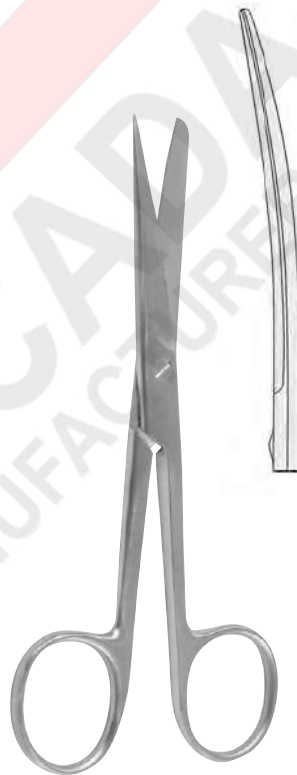

GRAZIL

13,0 cm, 5"	010-073-13
14,5 cm, 5 ³ / ₄ "	010-073-14

SURGICAL INSTRUMENTS

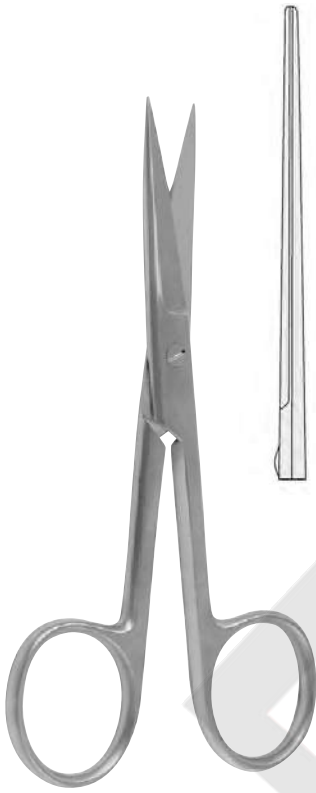

GRAZIL

13,0 cm, 5"	010-074-13
14,5 cm, 5 3/4"	010-074-14

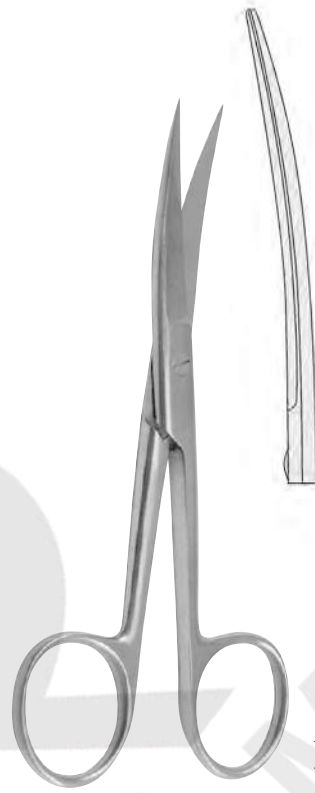

GRAZIL

13,0 cm, 5"	010-075-13
14,5 cm, 5 3/4"	010-075-14

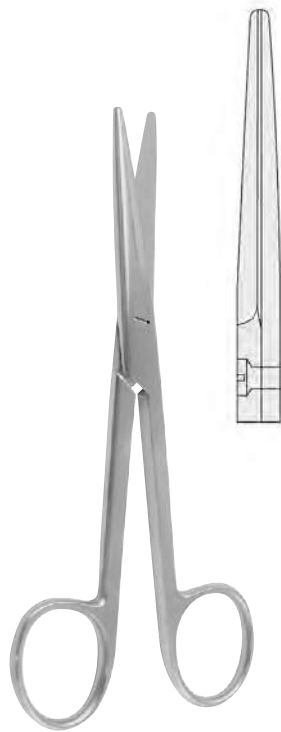

MAYO

14,5 cm, 5 3/4"	010-100-14
17,0 cm, 6 3/4"	010-100-17
23,0 cm, 9"	010-100-23
28,0 cm, 11"	010-100-28

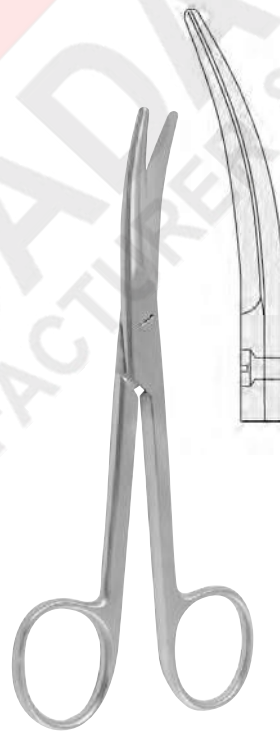

MAYO

14,5 cm, 5 3/4"	010-101-14
17,0 cm, 6 3/4"	010-101-17
23,0 cm, 9"	010-101-23
28,0 cm, 11"	010-101-28



MAYO-STILE

15,0 cm, 6"	010-102-15
17,0 cm, 6 3/4"	010-102-17
19,5 cm, 7 3/4"	010-102-19
21,0 cm, 8 1/4"	010-102-21

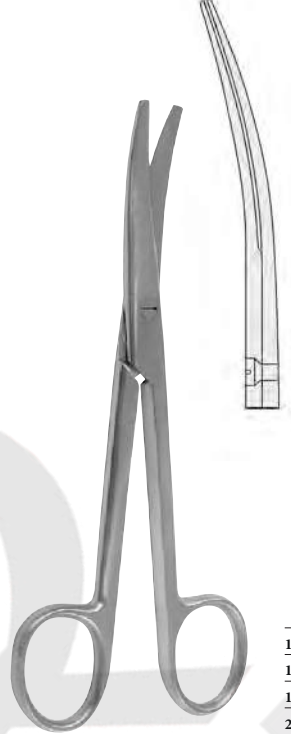

MAYO-STILE

15,0 cm, 6"	010-103-15
17,0 cm, 6 3/4"	010-103-17
19,5 cm, 7 3/4"	010-103-19
21,0 cm, 8 1/4"	010-103-21



MAYO-NOBLE

17,0 cm, 6 3/4"



010-104-17

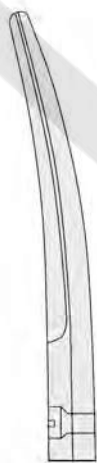

010-105-17

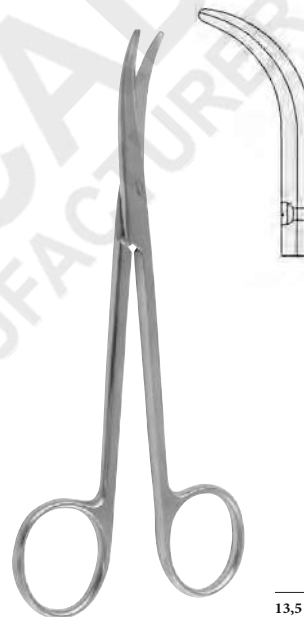

FOMON

13,5 cm, 5 3/8" 010-009-13

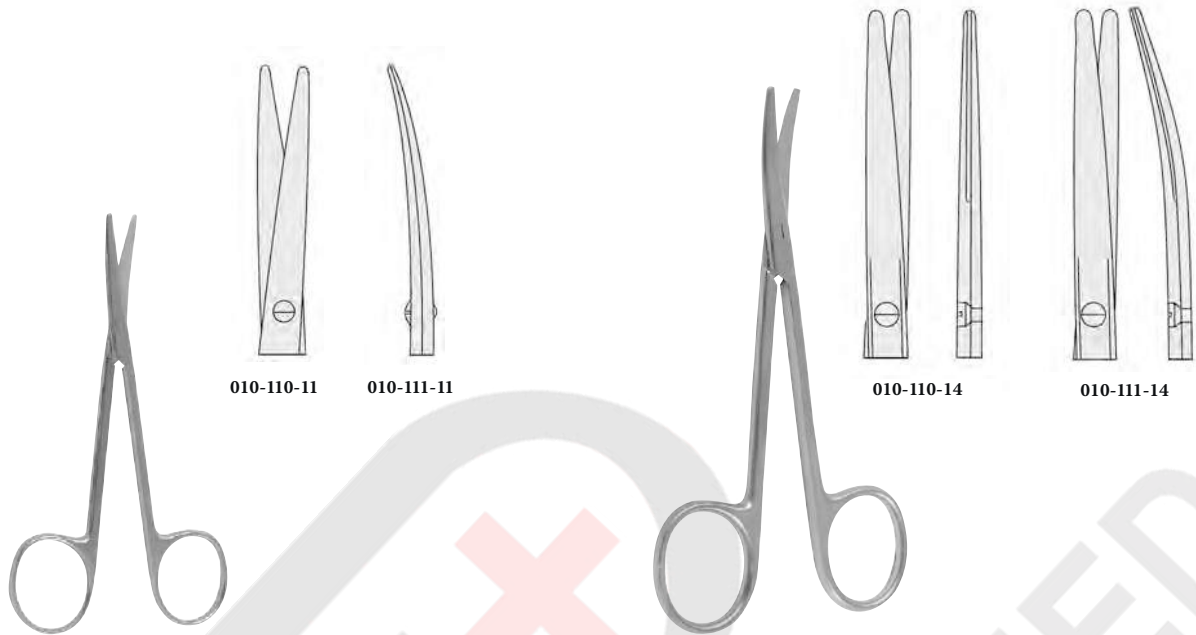

BABY-METZENBAUM
11,5 cm, 4 1/2"

METZENBAUM
14,5 cm, 5 3/4"

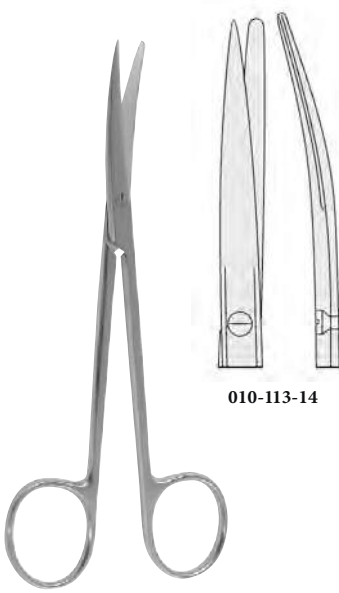

METZENBAUM
14,5 cm, 5 3/4"

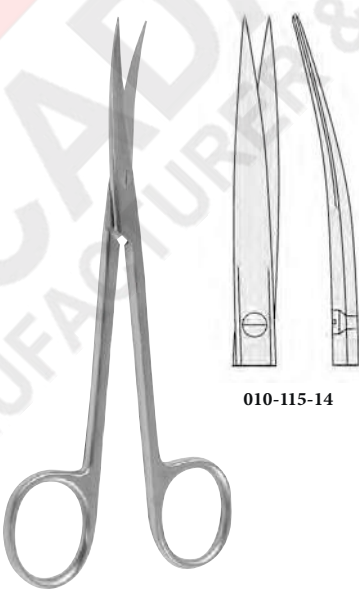

METZENBAUM
14,5 cm, 5 3/4"

SURGICAL INSTRUMENTS

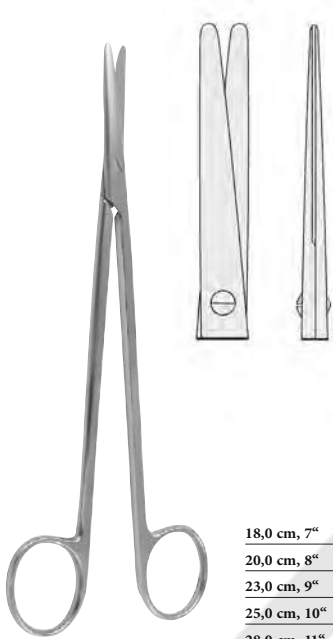

METZENBAUM

18,0 cm, 7"	010-110-18
20,0 cm, 8"	010-110-20
23,0 cm, 9"	010-110-23
25,0 cm, 10"	010-110-25
28,0 cm, 11"	010-110-28
30,0 cm, 12"	010-110-30

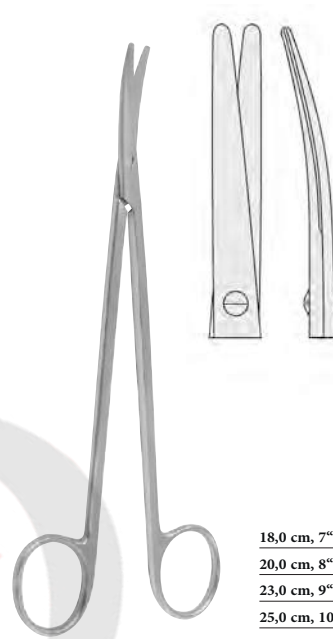

METZENBAUM

18,0 cm, 7"	010-111-18
20,0 cm, 8"	010-111-20
23,0 cm, 9"	010-111-23
25,0 cm, 10"	010-111-25
28,0 cm, 11"	010-111-28
30,0 cm, 12"	010-111-30

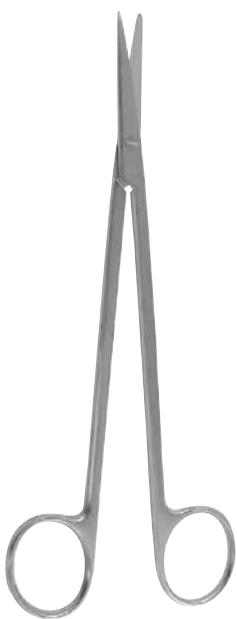

METZENBAUM

18,0 cm, 7"	010-112-18
20,0 cm, 8"	010-112-20
23,0 cm, 9"	010-112-23
25,0 cm, 10"	010-112-25
28,0 cm, 11"	010-112-28
30,0 cm, 12"	010-112-30



METZENBAUM

18,0 cm, 7"	010-113-18
20,0 cm, 8"	010-113-20
23,0 cm, 9"	010-113-23
25,0 cm, 10"	010-113-25
28,0 cm, 11"	010-113-28
30,0 cm, 12"	010-113-30

SURGICAL INSTRUMENTS



METZENBAUM

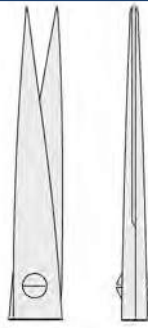

18,0 cm, 7"	010-114-18
20,0 cm, 8"	010-114-20
23,0 cm, 9"	010-114-23
25,0 cm, 10"	010-114-25
28,0 cm, 11"	010-114-28
30,0 cm, 12"	010-114-30

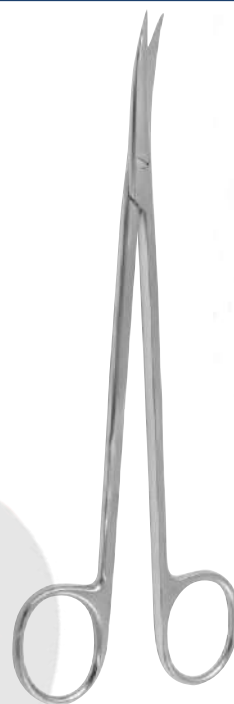

METZENBAUM

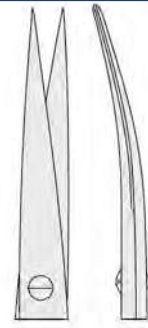

18,0 cm, 7"	010-115-18
20,0 cm, 8"	010-115-20
23,0 cm, 9"	010-115-23
25,0 cm, 10"	010-115-25
28,0 cm, 11"	010-115-28
30,0 cm, 12"	010-115-30



METZENBAUM-FINO

14,5 cm, 5 3/4"

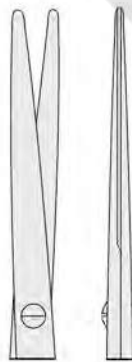

010-120-14



010-121-14

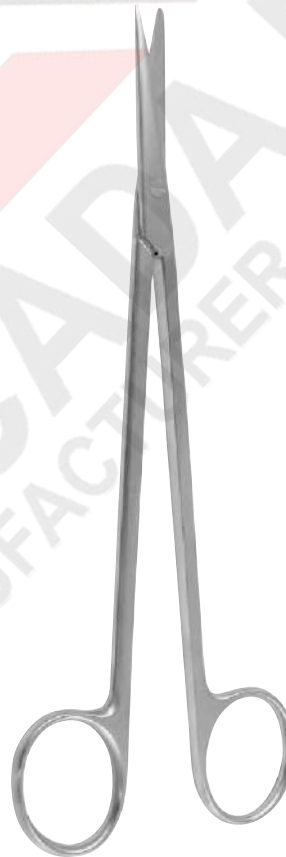

METZENBAUM-FINO

18,0 cm, 7"	010-120-18
20,0 cm, 8"	010-120-20
23,0 cm, 9"	010-120-23
25,0 cm, 10"	010-120-25
28,0 cm, 11"	010-120-28
30,0 cm, 12"	010-120-30

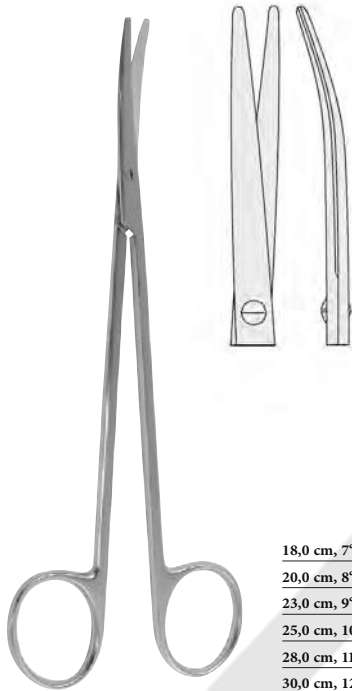

METZENBAUM-FINO

18,0 cm, 7"	010-121-18
20,0 cm, 8"	010-121-20
23,0 cm, 9"	010-121-23
25,0 cm, 10"	010-121-25
28,0 cm, 11"	010-121-28
30,0 cm, 12"	010-121-30



METZENBAUM-FINO
14,5 cm, 5 3/4"

010-124-14

010-125-14

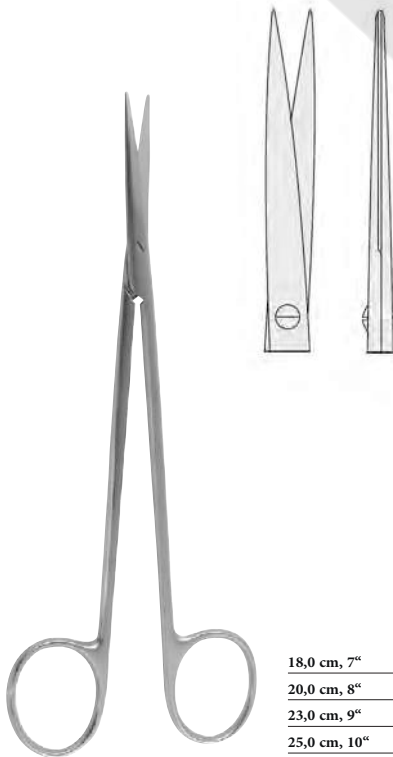

METZENBAUM-FINO

18,0 cm, 7"	010-124-18
20,0 cm, 8"	010-124-20
23,0 cm, 9"	010-124-23
25,0 cm, 10"	010-124-25
28,0 cm, 11"	010-124-28
30,0 cm, 12"	010-124-30

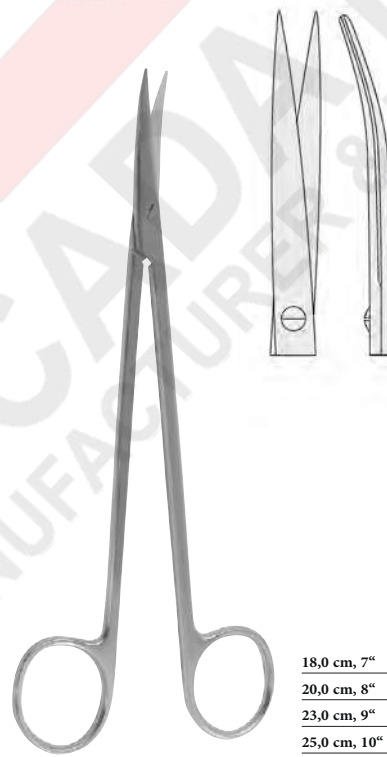

METZENBAUM-FINO

18,0 cm, 7"	010-125-18
20,0 cm, 8"	010-125-20
23,0 cm, 9"	010-125-23
25,0 cm, 10"	010-125-25
28,0 cm, 11"	010-125-28
30,0 cm, 12"	010-125-30

SURGICAL INSTRUMENTS

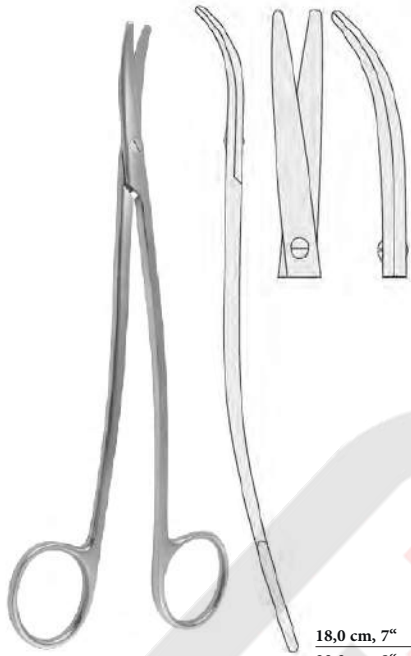

METZENBAUM-FINO S

18,0 cm, 7"	010-127-18
20,0 cm, 8"	010-127-20
23,0 cm, 9"	010-127-23

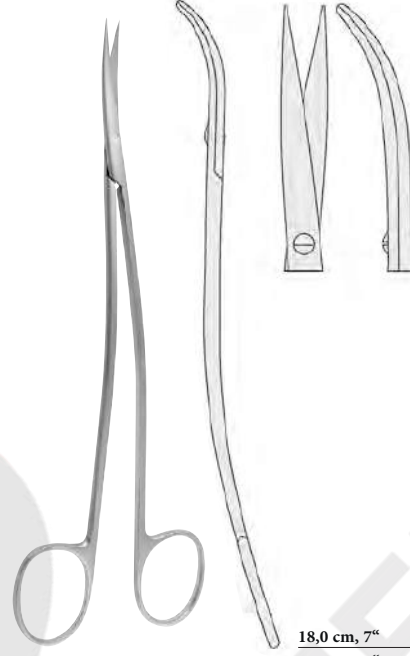

METZENBAUM-FINO S

18,0 cm, 7"	010-129-18
20,0 cm, 8"	010-129-20
23,0 cm, 9"	010-129-23



METZENBAUM-LAHEY

14,0 cm, 5 1/2" 010-137-14

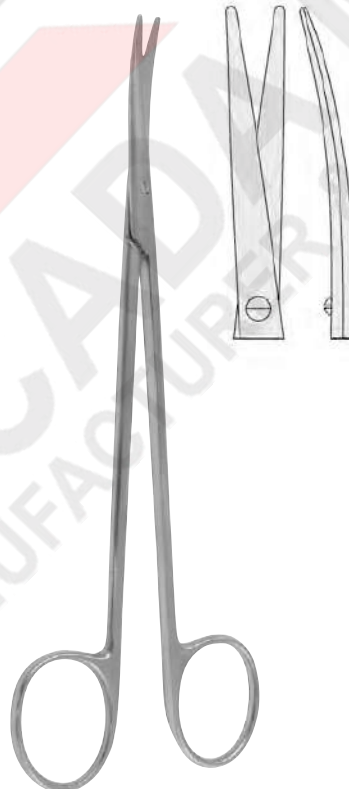

TOENNIS-ADSON

17,0 cm, 6 3/4" 010-139-17

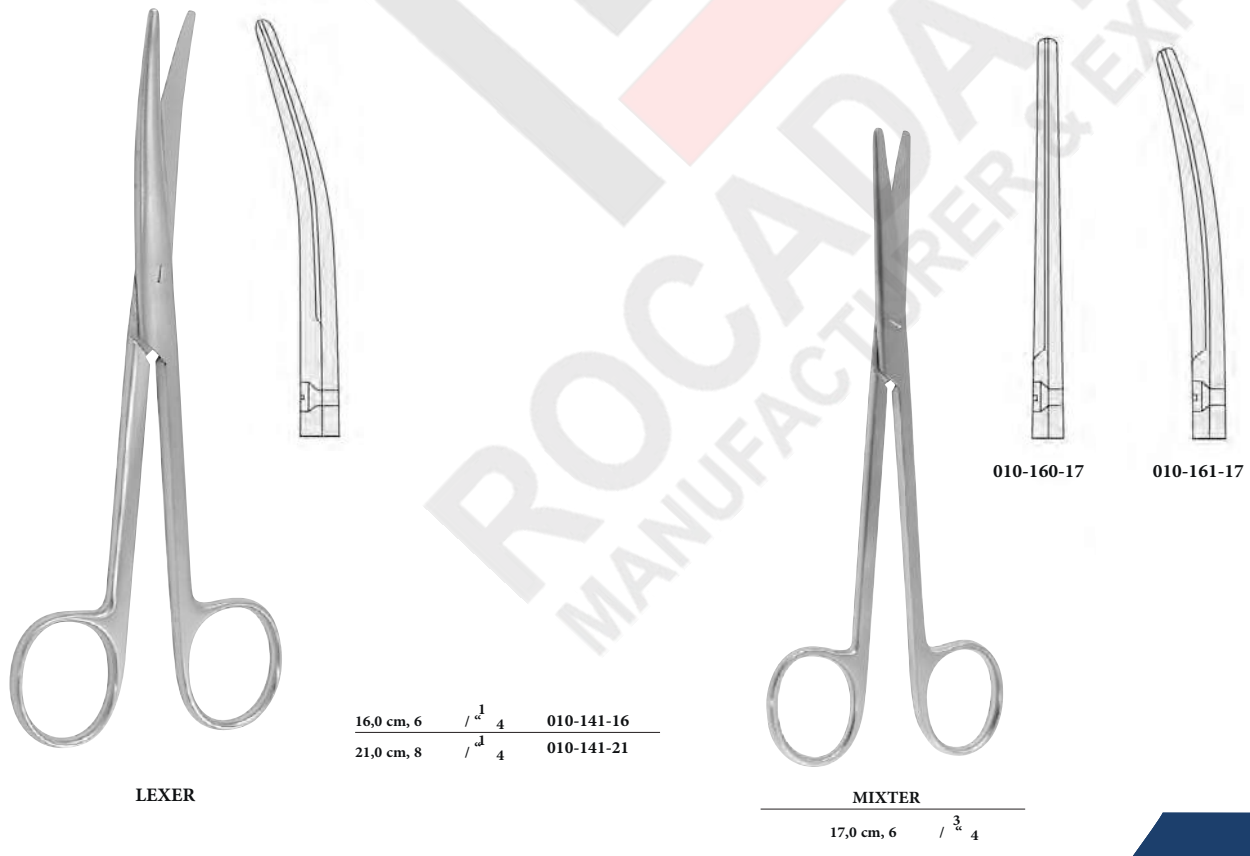
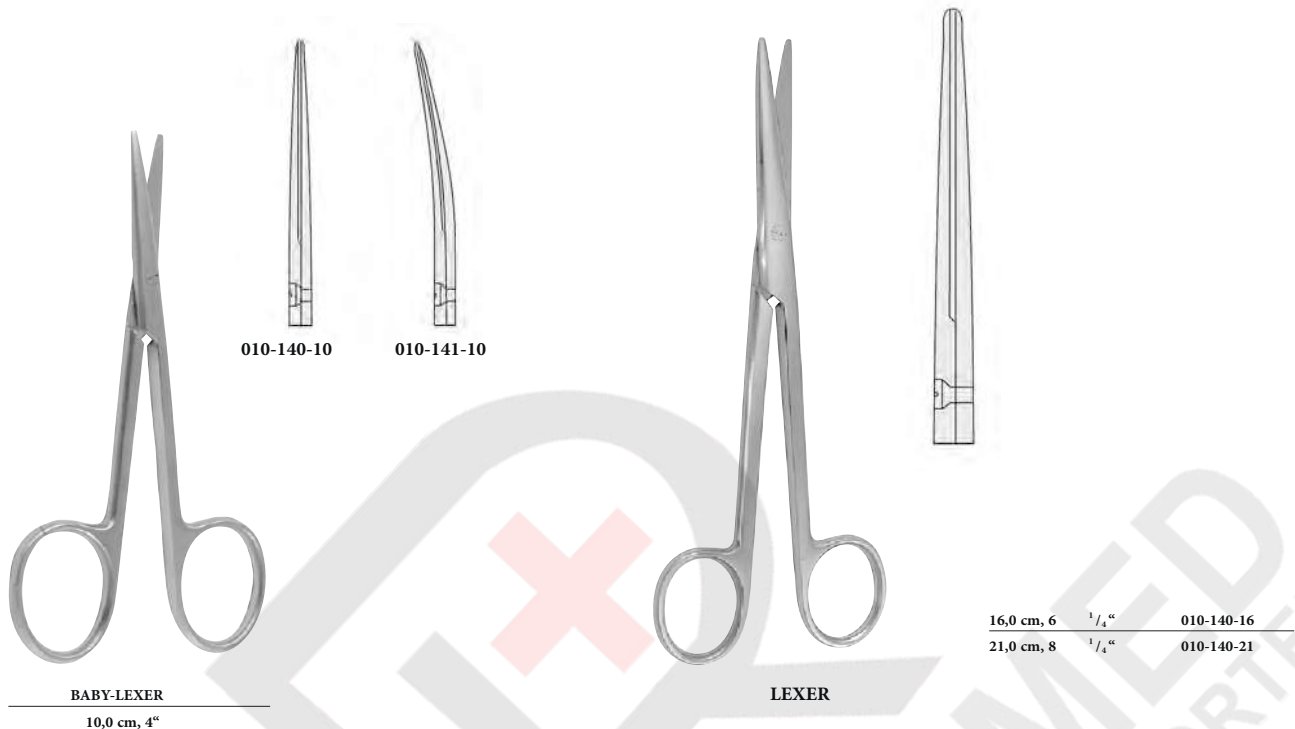

SURGICAL INSTRUMENTS



KILNER (RAGNELL)

12,0 cm, 4 ³ / ₄ "	010-200-12
15,0 cm, 6"	010-200-15
18,0 cm, 7"	010-200-18
20,0 cm, 8"	010-200-20



KILNER (RAGNELL)

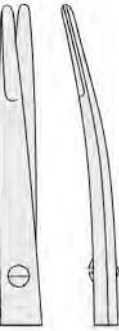

12,0 cm, 4 ³ / ₄ "	010-201-12
15,0 cm, 6"	010-201-15
18,0 cm, 7"	010-201-18
20,0 cm, 8"	010-201-20



REYNOLDS

15,0 cm, 6"	010-210-15
18,0 cm, 7"	010-210-18

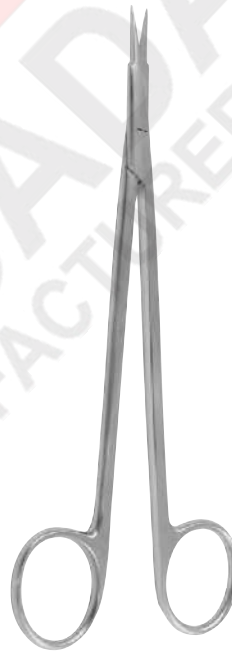

REYNOLDS

15,0 cm, 6"	010-211-15
18,0 cm, 7"	010-211-18
20,0 cm, 8"	010-211-20
23,0 cm, 9"	010-211-23
25,0 cm, 10"	010-211-25



THOREK

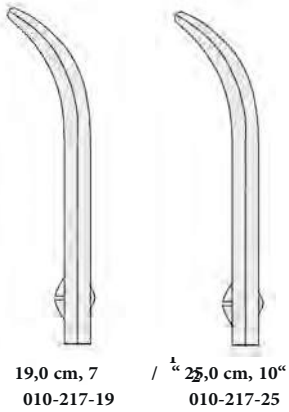

19,0 cm, 7
 010-217-19

25,0 cm, 10"
 010-217-25



15,0 cm, 6"

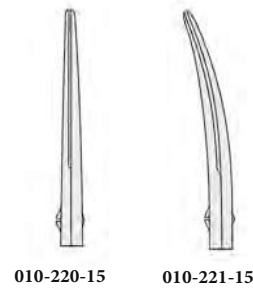

010-220-15

010-221-15

Nerv-Präparierscheren
 Nerve dissecting scissors
 Tijeras para nervios
 Forbici per dissezione di nervi



SANVENERO

14,0 cm, 5 1/2"

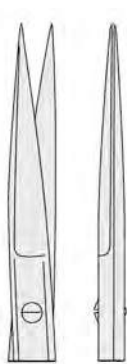

010-224-14

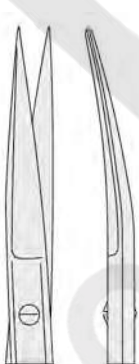

010-225-14



JOSEPH

14,0 cm, 5 1/2"

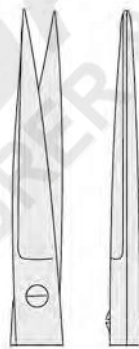

010-228-14

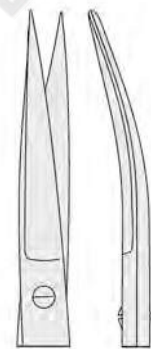

010-229-14



WAGNER
12,0 cm, 4 ³/₄"



010-230-12



010-231-12



010-234-12



010-235-12



STRABISMUS
11,5 cm, 4 ¹/₂"



010-240-11



010-241-11



IRIS



9,0 cm, 4 ¹ / ₈ "	010-244-09
10,5 cm, 4 ¹ / ₈ "	010-244-10
11,5 cm, 4 ¹ / ₂ "	010-244-11



IRIS



9,0 cm, 4 ¹ / ₈ "	010-245-09
10,5 cm, 4 ¹ / ₈ "	010-245-10
11,5 cm, 4 ¹ / ₂ "	010-245-11

SURGICAL INSTRUMENTS

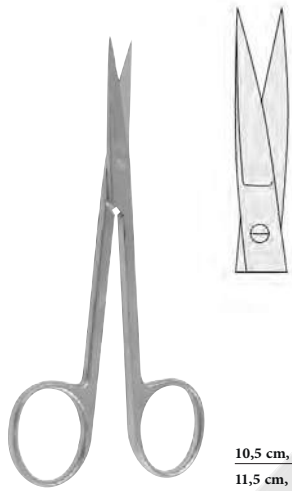

IRIS

10,5 cm, 4 $\frac{1}{8}$ " 010-250-10
11,5 cm, 4 $\frac{1}{2}$ " 010-250-11



IRIS

10,5 cm, 4 $\frac{1}{8}$ " 010-251-10
11,5 cm, 4 $\frac{1}{2}$ " 010-251-11



11,5 cm, 4 $\frac{1}{2}$ "
010-261-11



11,5 cm, 4 $\frac{1}{2}$ "
010-263-11

SURGICAL INSTRUMENTS

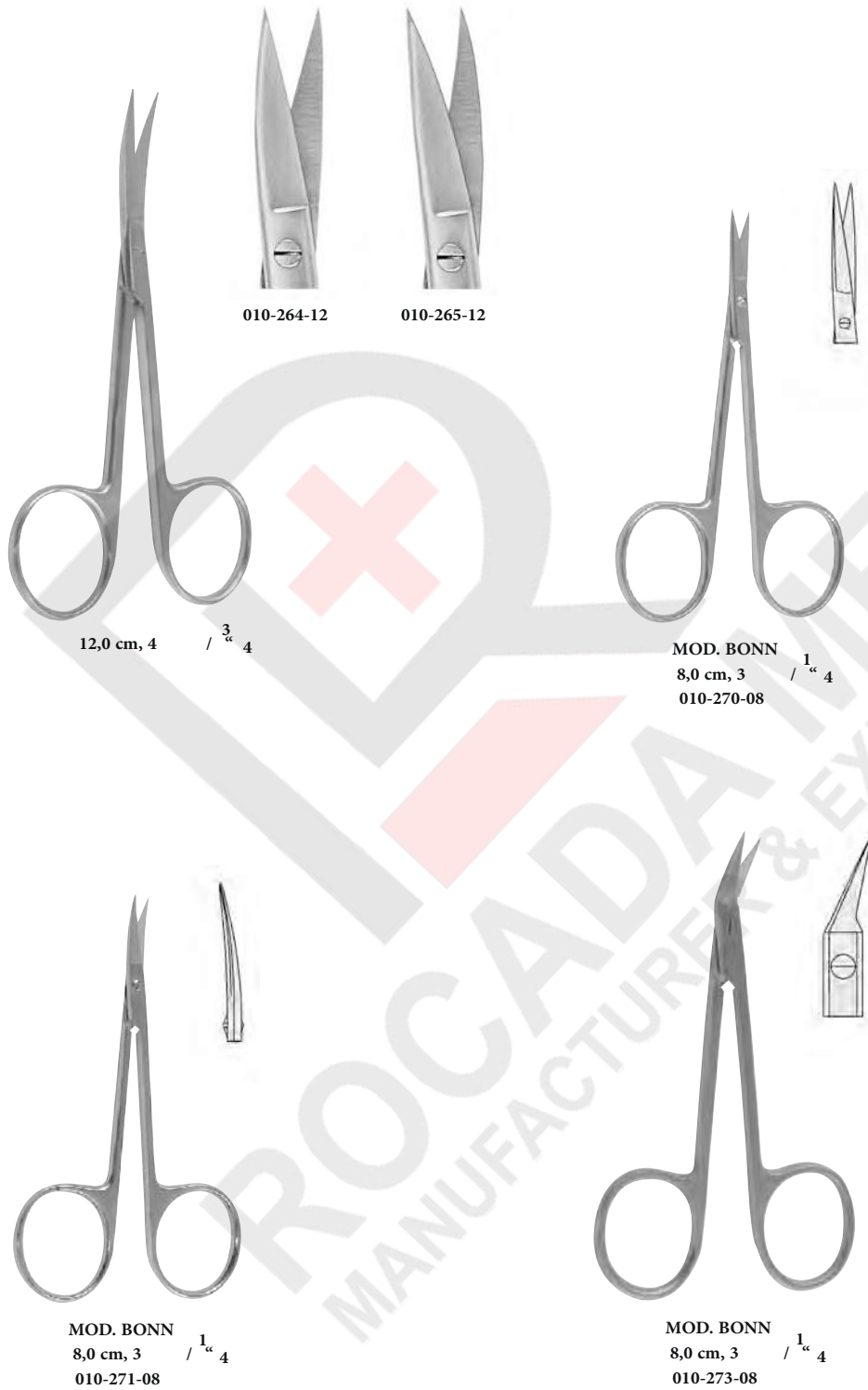

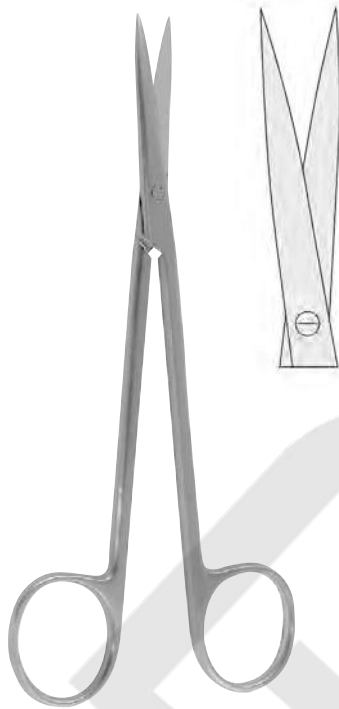

BROPHY (SULLIVAN) $\frac{1}{8}''$
 14,0 cm, 5 / 2
 010-276-14

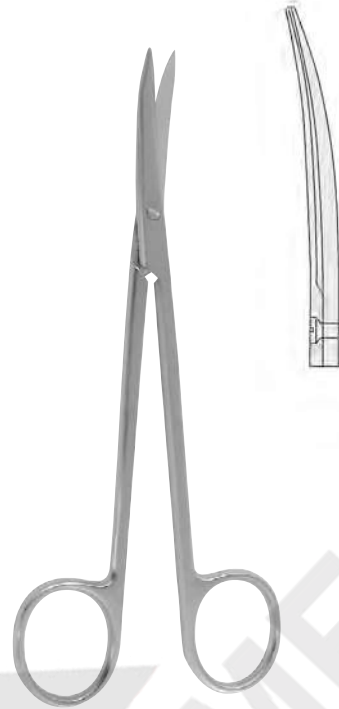

BROPHY (SULLIVAN) $\frac{1}{8}''$
 14,0 cm, 5 / 2
 010-277-14



010-280-12



010-283-12



010-285-12



10,5 cm, 4 $\frac{1}{8}''$

010-290-10



010-291-10



11,5 cm, 4 $\frac{1}{2}''$

010-290-11

010-291-11



10,5 cm, 4 $\frac{1}{8}''$

010-294-10



010-295-10



11,5 cm, 4 $\frac{1}{2}''$

010-294-11

010-295-11



LANDOLT

12,5 cm, 5"



STEVENS



Inzisionscheren
Incision scissors
Tijeras para incisión
Forbici vascolare e per fistole

13,0 cm, 5"	010-300-13
14,5 cm, 5 3/4"	010-300-14



RICHTER
14,5 cm, 5 3/4"
010-310-14



FERGUSSON		
16,5 cm, 6 1/4"	010-315-16	
18,0 cm, 7"	010-315-18	

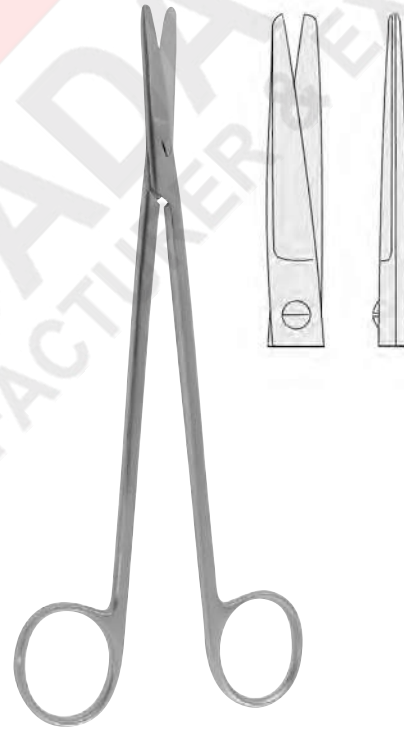

TOENNIS
18,0 cm, 7"
010-324-18

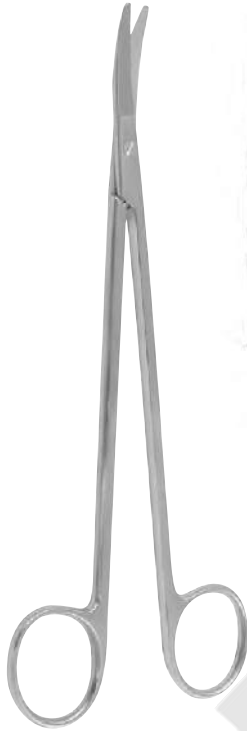

TOENNIS
 18,0 cm, 7"
 010-325-18

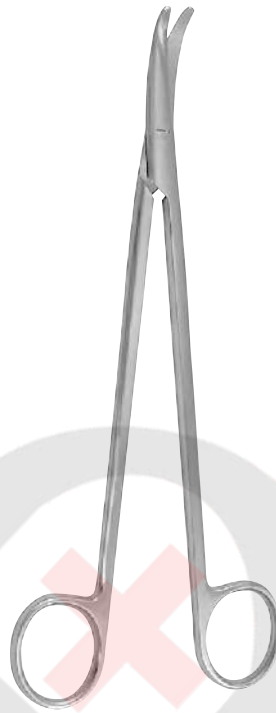

HALLE
 19,0 cm, 7 1/4"
 010-341-19



FOMON
 15,0 cm, 6"
 010-343-15



SPENCER		
9,0 cm, 4	1/8"	010-400-09
10,5 cm, 4	1/8"	010-400-10
13,0 cm, 5"		010-400-13



LITTAUER		
11,5 cm, 4	1/4"	010-402-11
14,0 cm, 5	1/2"	010-402-14

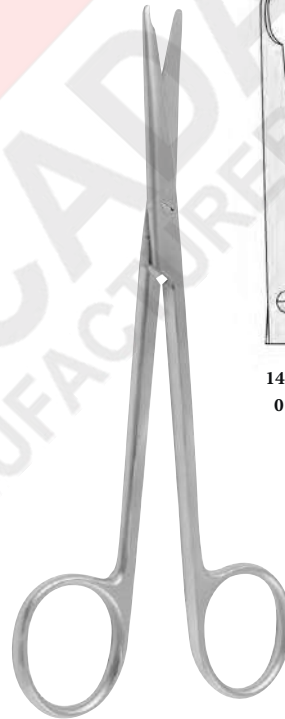

BUCK

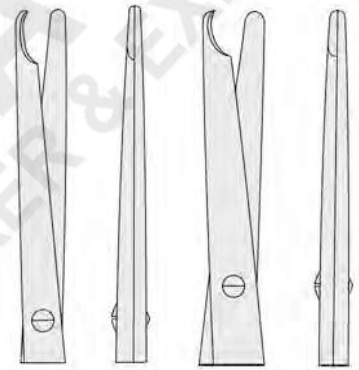

14,5 cm, 5 3/8"
 010-404-14

18,0 cm, 7"
 010-404-18

SURGICAL INSTRUMENTS

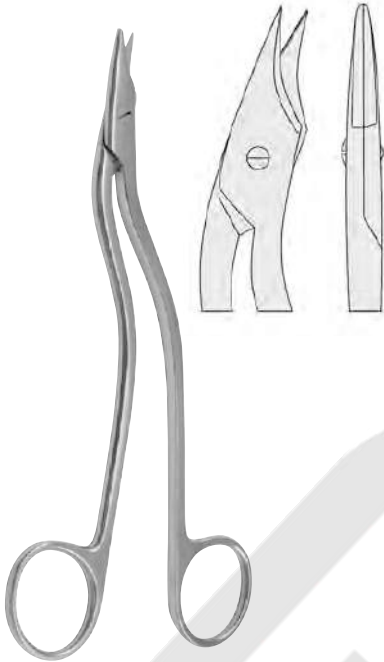

HEATH
16,0 cm, 6 / $\frac{1}{4}$ 4
010-408-16

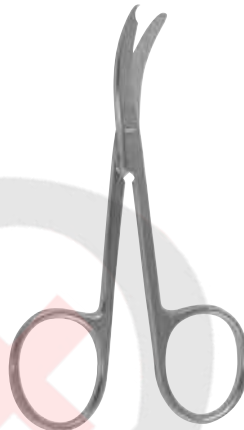

NORTHBENT
9,0 cm, 3 / $\frac{1}{4}$ 2
010-411-19



NORTHBENT
13,0 cm, 5"
010-413-13



EISELSBERG
12,0 cm, 4 / $\frac{3}{4}$ 4
010-415-12

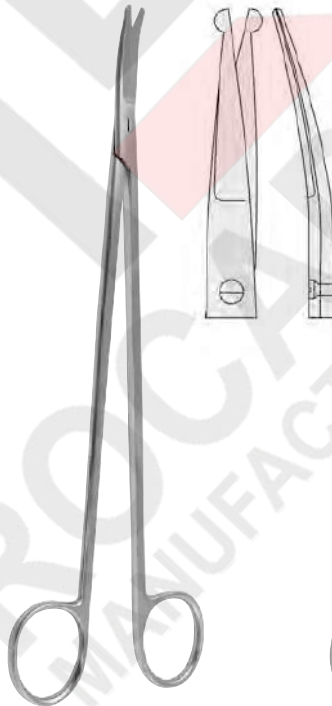

STRULLY
22,0 cm, 8 / $\frac{5}{8}$ 8
010-450-22

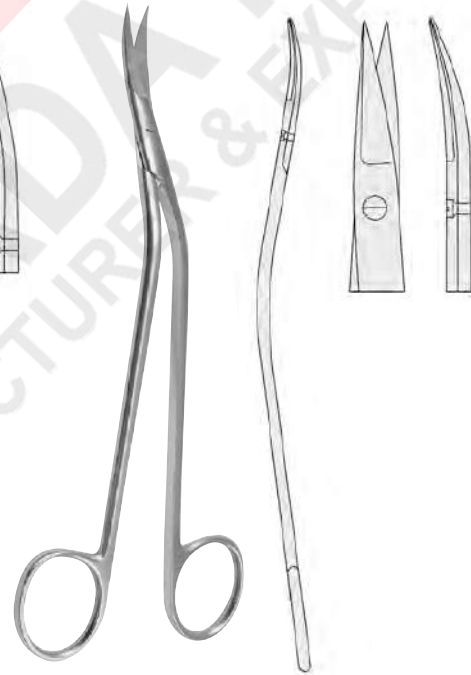

DANDY
17,0 cm, 6 / $\frac{3}{4}$ 4
010-453-17

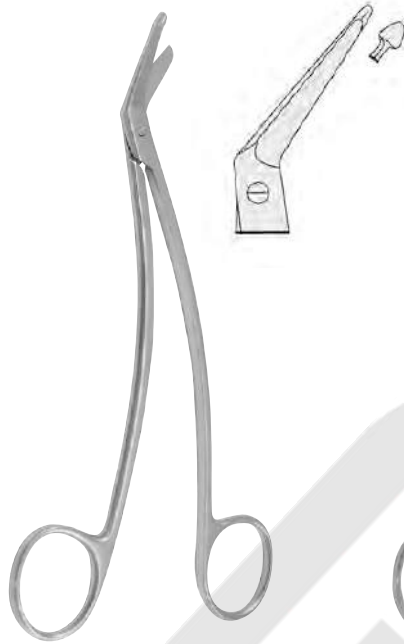

SCHMIEDEN-TAYLOR
 17,0 cm, 6 / $\frac{3}{4}$ 4
 010-457-17

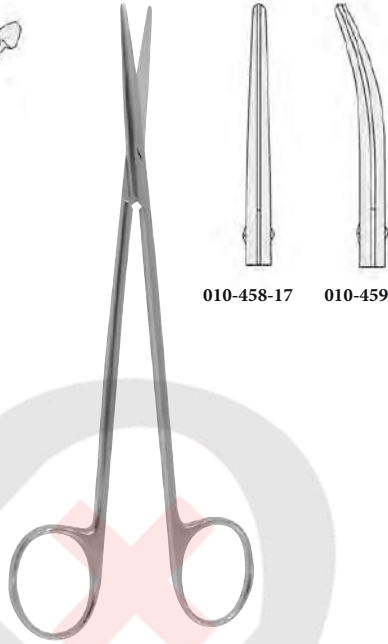

010-458-17 010-459-17

LINCOLN
 17,0 cm, 6 / $\frac{3}{4}$ 4



HEYMANN
 18,0 cm, 7"
 010-501-18



COTTLE
 16,0 cm, 6 / $\frac{1}{4}$ 4
 010-511-16

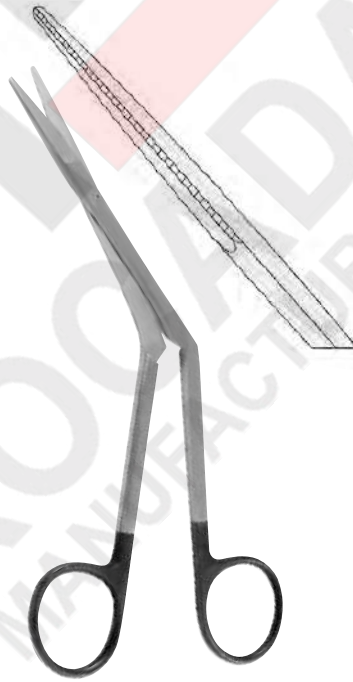

KIRSTEN
 18,0 cm, 7"
 010-517-18



CAPLAN
 22,0 cm, 8 / $\frac{5}{8}$ 8
 010-519-22

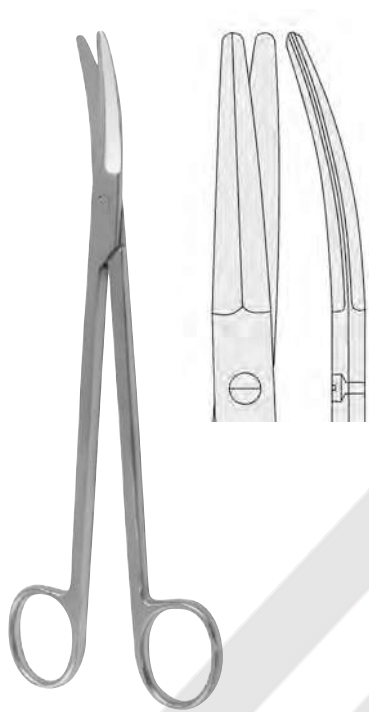

BOETTCHER
18,0 cm, 7"
010-521-18

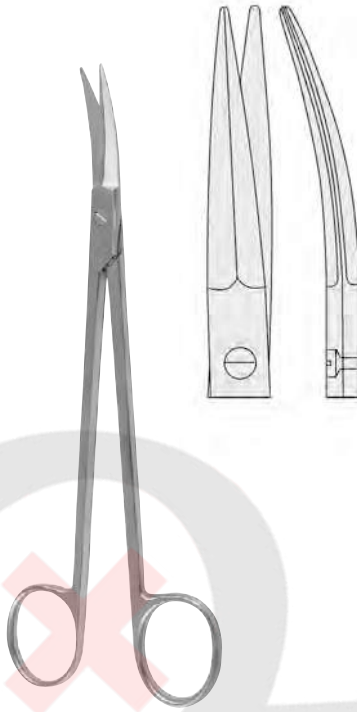

PRINCE
17,5 cm, 6" / 5/8"
010-523-17

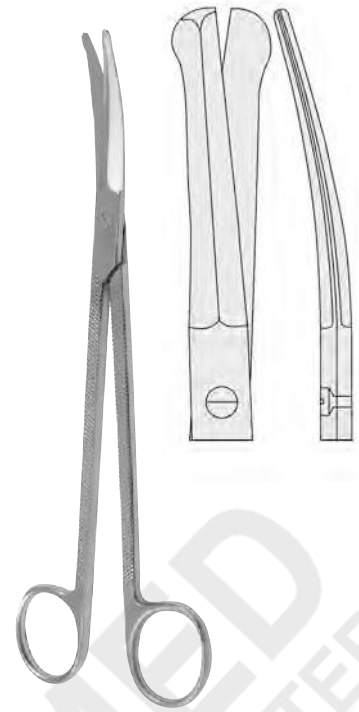

GOOD
19,0 cm, 7" / 1/2"
010-525-19



CARTILAGE
20,0 cm, 8"
010-528-20

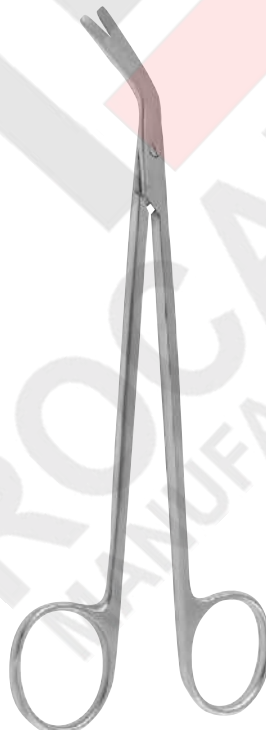

DE BAKEY

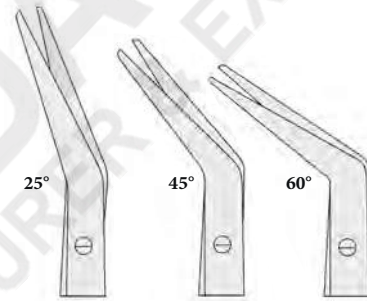

17,5 cm, 6"	5/8"	010-540-25	010-540-45	010-540-60
19,5 cm, 7"	3/4"	010-541-25	010-541-45	010-541-60
21,0 cm, 8"	1/4"	010-542-25	010-542-45	010-542-60
23,0 cm, 9"		010-543-25	010-543-45	010-543-60
28,0 cm, 11"		010-544-25	010-544-45	010-544-60

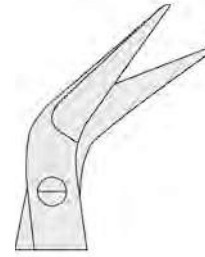
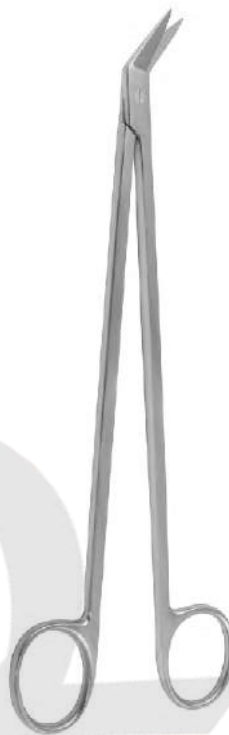
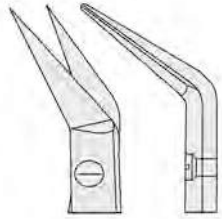

POTTS-SMITH
 18,0 cm, 7"
 010-547-18

POTTS DE MARTEL		
21,0 cm, 8 1/4"	010-548-21	
24,0 cm, 9 1/2"	010-548-24	

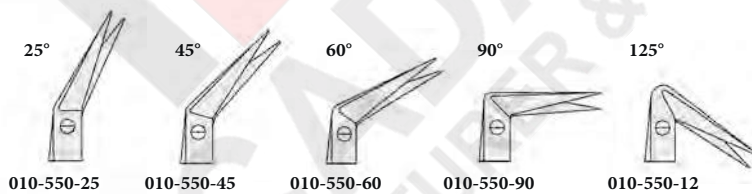
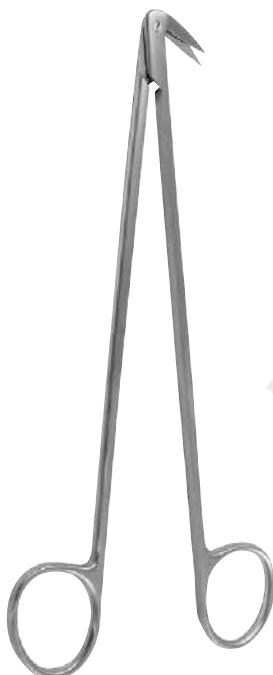

DIETRICH-HEGEMANN
 19,0 cm, 7 1/2"

SURGICAL INSTRUMENTS



DIETHRICH
20,0 cm, 7 / $\frac{1}{2}$ 2
010-552-12

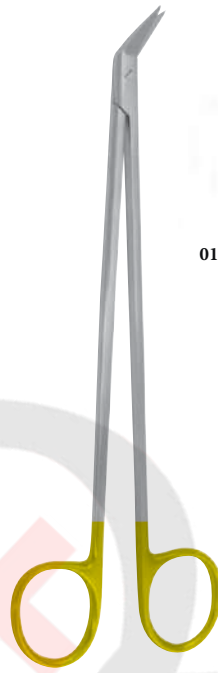

POTTS-SMITH
19,0 cm, 7 / $\frac{1}{2}$ 2

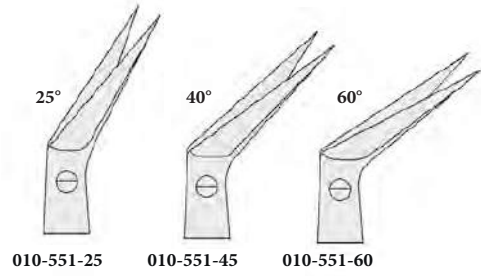

010-551-25

010-551-45

010-551-60

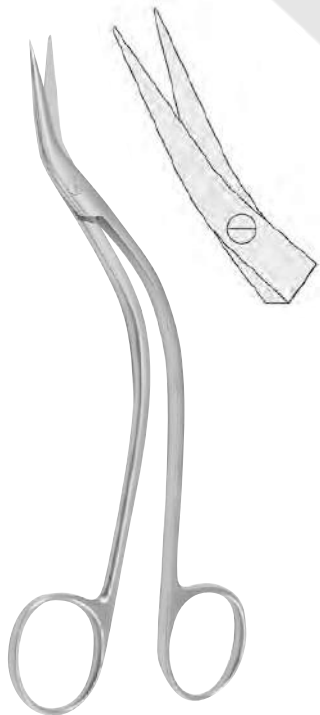

DE BAKEY
15,5 cm, 6"
010-560-15

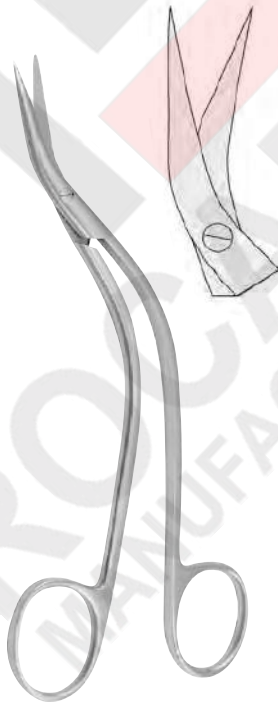

DE BAKEY
15,5 cm, 6"
010-561-15

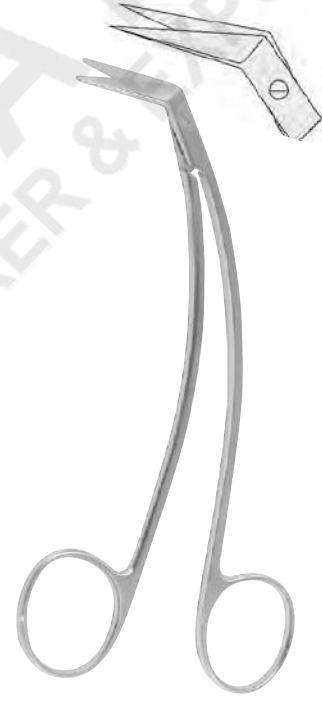

DE BAKEY
15,5 cm, 6"
010-562-15

SURGICAL INSTRUMENTS



MC INDOE
 19,0 cm, 7
 010-570-19

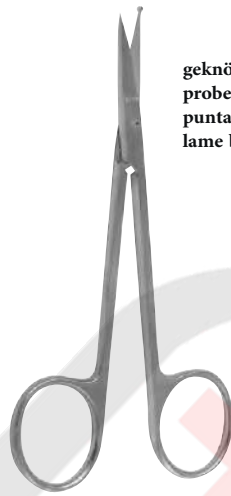

geknöpftes Blatt
 probe-pointed blade
 punta botonda
 lame bottonuta

11,5 cm, 4
 010-572-11



CRAFOORD
 30,0 cm, 12"
 010-575-30



SATINSKY
 15,5 cm, 9
 010-577-24

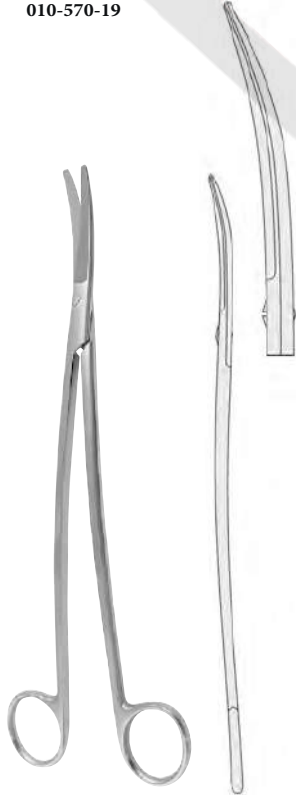

KLINGENBERG-LOTH
 23,0 cm, 9"
 010-579-23



SIMS

20,0 cm, 8"
 010-600-20

23,0 cm, 9"
 010-600-23

010-602-20

010-602-23

010-604-20
 010-604-23

SURGICAL INSTRUMENTS

SURGICAL INSTRUMENTS

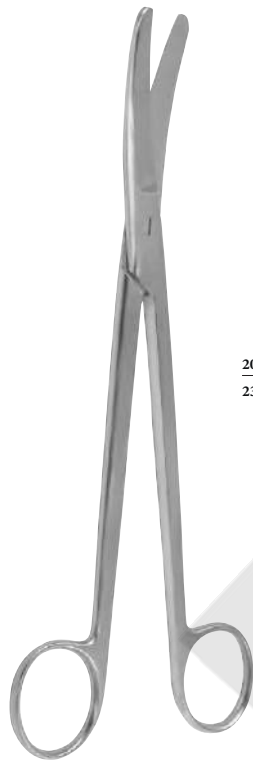

SIMS

20,0 cm, 8"	010-601-20	010-603-20	010-605-20
23,0 cm, 9"	010-601-23	010-603-23	010-605-23

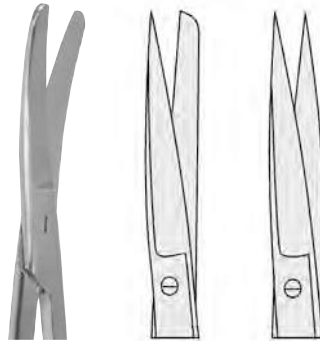

SIEBOLD
24,0 cm, 9" / $\frac{1}{4}$ " 2
010-620-24

BOZEMANN
22,0 cm, 8" / $\frac{3}{4}$ " 4
010-622-22



DOYEN

16,0 cm, 6" $\frac{1}{4}$ "	010-610-16	010-61	1-16	010-612-16
17,5 cm, 6" $\frac{5}{8}$ "	010-610-17	010-61	1-17	

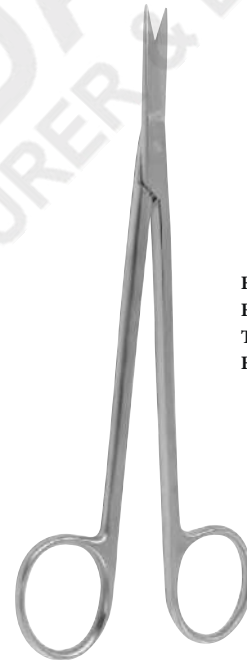

KELLY

16,0 cm, 6" $\frac{1}{4}$ "	010-634-16
18,0 cm, 7"	010-634-18

Fistelscheren
Fistula scissors
Tijeras para fistulas
Forbici per fistole

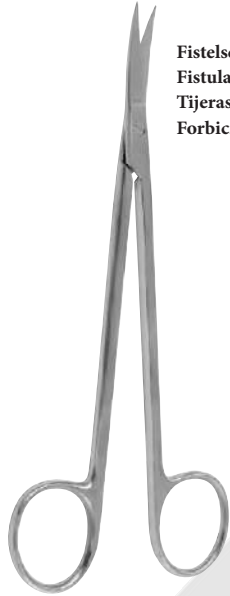

Fistelscheren
 Fistula scissors
 Tijeras para fistulas
 Forbici per fistole

KELLY	
16,0 cm, 6	1/4" 010-635-16
18,0 cm, 7"	010-635-18



WERTHEIM	
19,5 cm, 7	3/4" 010-640-19
22,5 cm, 8	3/4" 010-640-23



010-651-18

DUBOIS	
27,0 cm, 10	5/8" 010-650-18

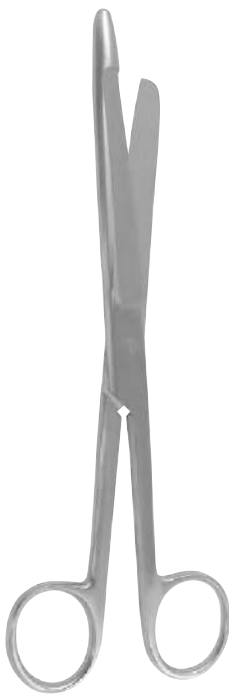

21,0 cm, 8	1/4" 010-670-21
------------	-----------------

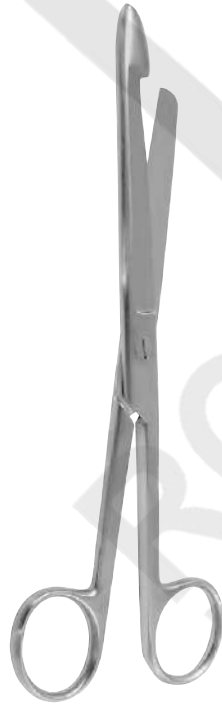

21,0 cm, 8	1/4" 010-672-21
------------	-----------------



21,0 cm, 8	1/4" 010-674-21
------------	-----------------



LLOYD-DAVIES	
27,0 cm, 10	5/8" 010-677-27



SURGICAL INSTRUMENTS

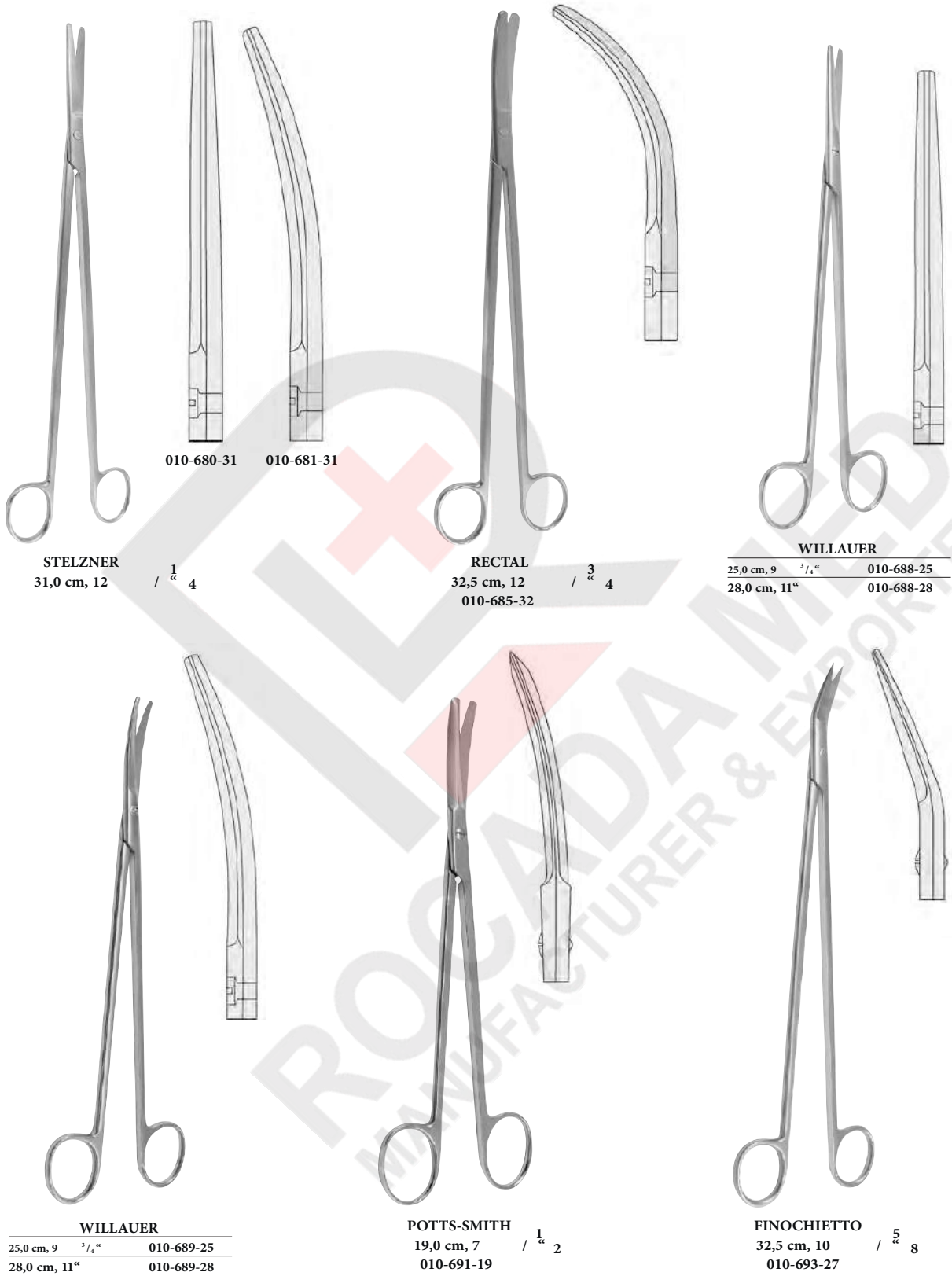

SURGICAL INSTRUMENTS

STELZNER
31,0 cm, 12 / $\frac{1}{4}$ 4

010-680-31 010-681-31

RECTAL
32,5 cm, 12 / $\frac{3}{4}$ 4

WILLAUER
25,0 cm, 9 $\frac{3}{4}$ " 010-688-25
28,0 cm, 11" 010-688-28

WILLAUER
25,0 cm, 9 $\frac{3}{4}$ " 010-689-25
28,0 cm, 11" 010-689-28

POTTS-SMITH
19,0 cm, 7 / $\frac{1}{2}$ 2
010-691-19

FINOCHIETTO
32,5 cm, 10 / $\frac{5}{8}$ 8
010-693-27

Lungenscheren, Dammscheren, Nabelschnurscheren
 Lobectomy Scissors, Episiotomy Scissors, Umbilical
 Cord Scissors Tijera para lobectomía, Tijeras para
 episiotomía, Tijeras umbilicales Forbici per lobo,
 Forbici per episiotomia, Forbici ombelicali



WALDMANN
 18,0 cm, 7"
 010-695-18



BRAUN-STADLER
 14,5 cm, 5 ³/₄" 010-701-14
 20,0 cm, 8" 010-701-20



20,0 cm, 8"
 010-703-20



MOD. USA
 10,5 cm, 4 ¹/₄"
 010-706-10



BUSCH
 13,5 cm, 5 ³/₈" 010-707-13
 16,0 cm, 6 ¹/₄" 010-707-16



SCHUMACHER
 16,0 cm, 16 ¹/₄"
 010-709-16

SURGICAL INSTRUMENTS

SURGICAL INSTRUMENTS



gezahnt
serrated
dentada
dentata

UNIVERSAL
12,0 cm, 4" / 3" 4"
010-800-12

LISTER

9,0 cm, 3"	1/2"	010-900-09
11,0 cm, 4"	3/8"	010-900-11
14,0 cm, 5"	1/2"	010-900-14
18,0 cm, 7"		010-900-18
20,0 cm, 8"		010-900-20

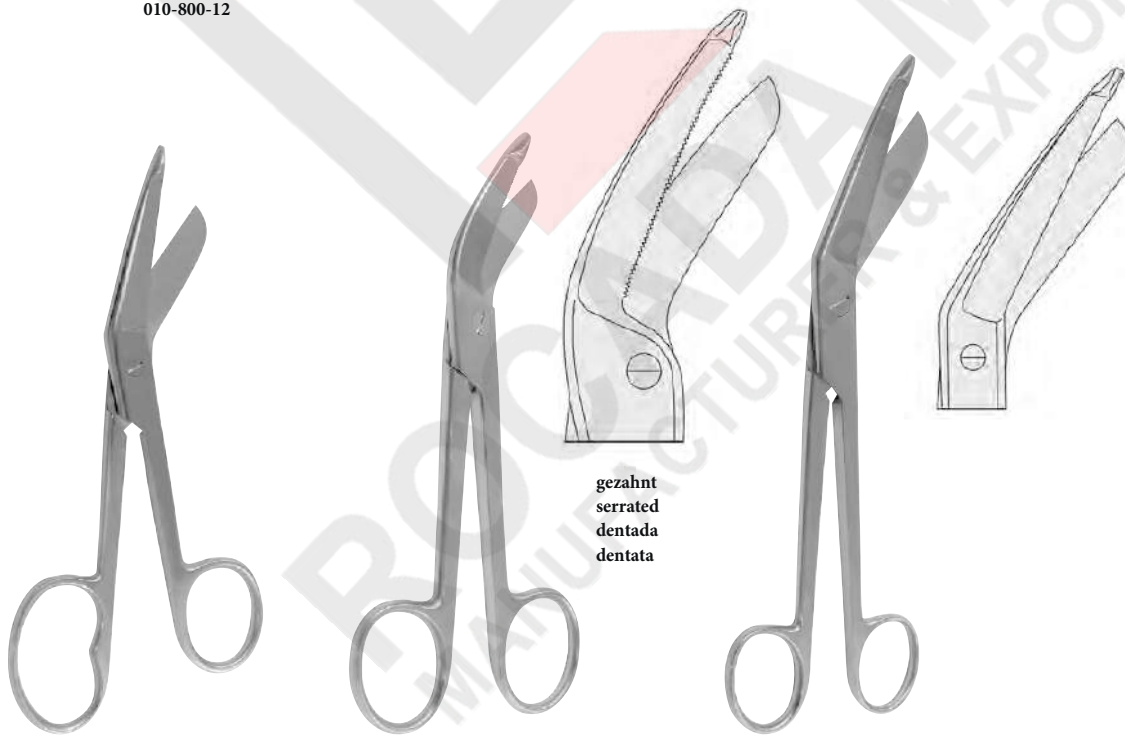

gezahnt
serrated
dentada
dentata

LISTER

18,5 cm, 7"	1/4"	010-901-18
21,0 cm, 8"	1/4"	010-901-21

LISTER-EXCENTRIC

16,0 cm, 6"	1/4"	010-903-16
19,0 cm, 7"	1/2"	010-903-19

BERGMANN

23,0 cm, 9"		010-905-23
-------------	--	------------



ESMARCH
 20,0 cm, 8"
 22,0 cm, 8 1/4"

010-907-20
010-907-22



KNOWLES
 14,0 cm, 5 1/4"

010-920-14

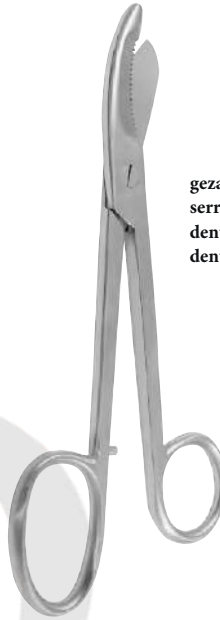

BRUNS
 24,0 cm, 9 1/4"

010-909-24
010-910-24

gezahnt
 serrated
 dentada
 dentata



LORENZ
 23,0 cm, 9"

010-930-23

bis 134°C autoklavierbar
 autoclavable up to 134°C
 esterilizabile en autoclave hasta 134°C
 Sterilizabile in autoclave fino 134°C

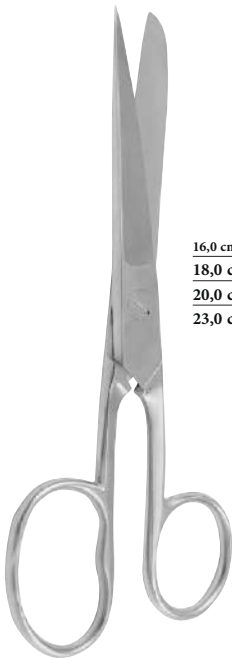

**SMITH
 (MOD. USA)**

16,0 cm, 6 1/4"	010-940-16
18,0 cm, 7"	010-940-18
20,0 cm, 8"	010-940-20
23,0 cm, 9"	010-940-23



20,0 cm, 8"
 010-941-20

gezahnt
 serrated
 dentada
 dentata



UNIVERSAL

14,0 cm, 5 1/2"	010-950-14
16,0 cm, 6 1/4"	010-950-16
18,0 cm, 7"	010-950-18

gezahnt
 serrated
 dentada
 dentata

SURGICAL INSTRUMENTS

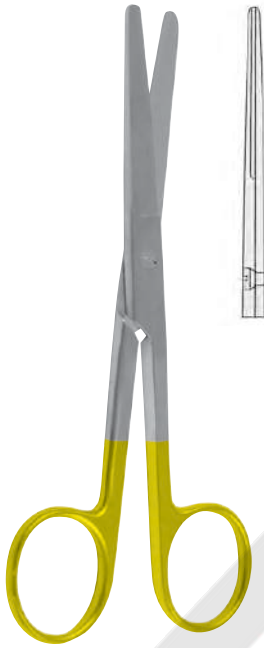

STANDARD		
14,5 cm, 5	$\frac{3}{4}$ "	011-000-14
16,5 cm, 6	$\frac{1}{2}$ "	011-000-16
18,5 cm, 7	$\frac{1}{4}$ "	011-000-18

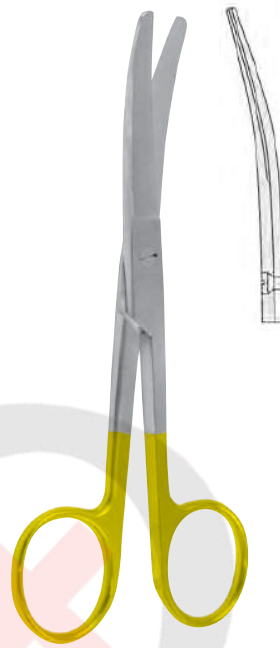

STANDARD		
14,5 cm, 5	$\frac{3}{4}$ "	011-001-14
16,5 cm, 6	$\frac{1}{2}$ "	011-001-16
18,5 cm, 7	$\frac{1}{4}$ "	011-001-18

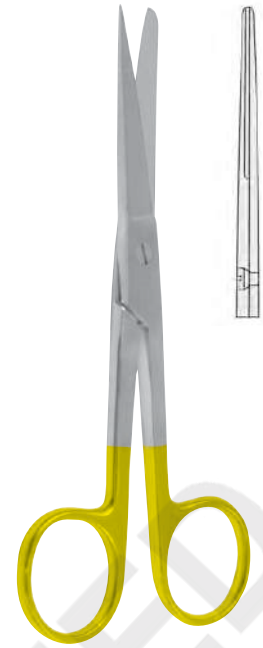

STANDARD		
14,5 cm, 5	$\frac{3}{4}$ "	011-002-14
16,5 cm, 6	$\frac{1}{2}$ "	011-002-16
18,5 cm, 7	$\frac{1}{4}$ "	011-002-18

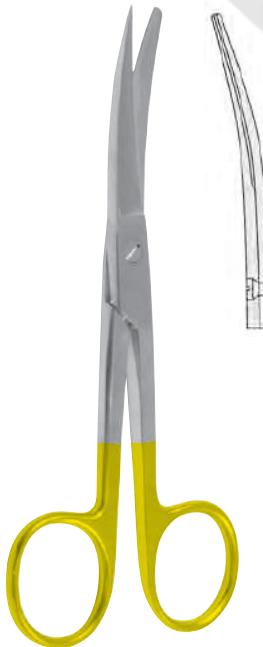

STANDARD		
14,5 cm, 5	$\frac{3}{4}$ "	011-003-14
16,5 cm, 6	$\frac{1}{2}$ "	011-003-16
18,5 cm, 7	$\frac{1}{4}$ "	011-003-18

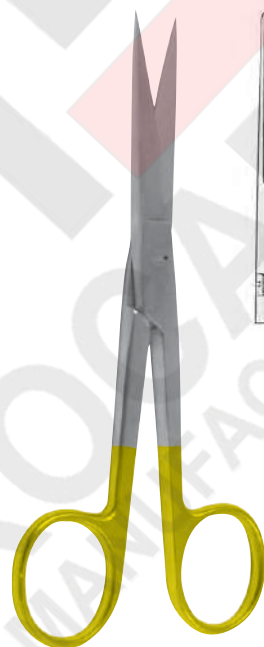

STANDARD		
14,5 cm, 5	$\frac{3}{4}$ "	011-004-14
16,5 cm, 6	$\frac{1}{2}$ "	011-004-16
18,5 cm, 7	$\frac{1}{4}$ "	011-004-18



STANDARD		
14,5 cm, 5	$\frac{3}{4}$ "	011-005-14
16,5 cm, 6	$\frac{1}{2}$ "	011-005-16
18,5 cm, 7	$\frac{1}{4}$ "	011-005-18

Chirurgische Scheren mit Hartmetallschneiden
 Surgical Scissors with tungsten carbide edges
 Tijeras para cirugía con filos de carburo tungsteno
 Forbici per chirurgia con lame in carburo di tungsteno



MAYO		
14,5 cm, 5"	$\frac{3}{4}$ "	011-100-14
17,0 cm, 6"	$\frac{3}{4}$ "	011-100-17
23,0 cm, 9"		011-100-23

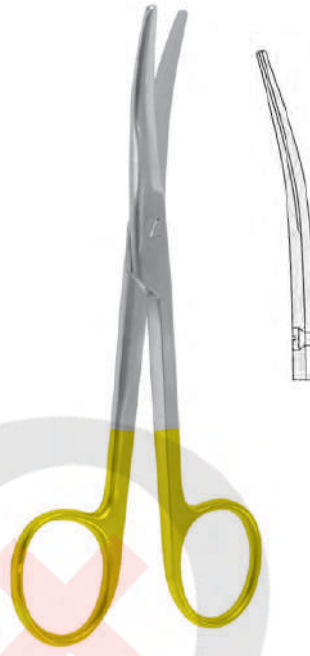

MAYO		
14,5 cm, 5"	$\frac{3}{4}$ "	011-101-14
17,0 cm, 6"	$\frac{3}{4}$ "	011-101-17
23,0 cm, 9"		011-101-23

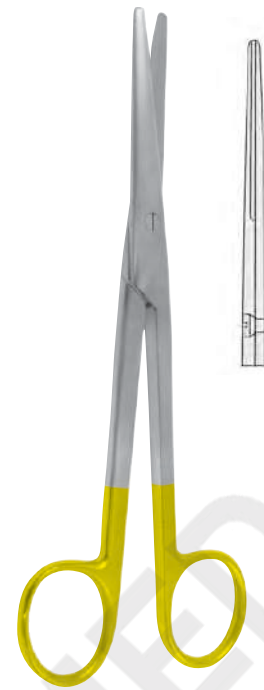

MAYO-STILLE		
15,0 cm, 6"		011-102-15
17,0 cm, 6"	$\frac{3}{4}$ "	011-102-17

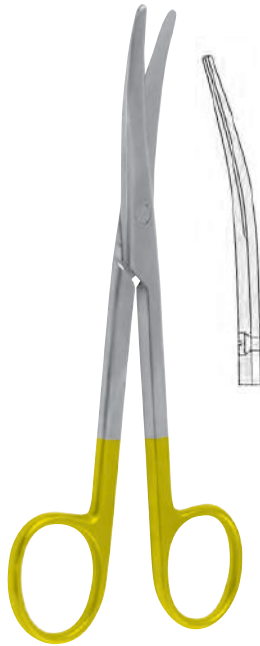

MAYO-STILLE		
15,0 cm, 6"		011-103-15
17,0 cm, 6"	$\frac{3}{4}$ "	011-103-17



LEXER		
16,0 cm, 6"	$\frac{1}{4}$ "	011-140-16
21,0 cm, 8"	$\frac{1}{4}$ "	011-140-21

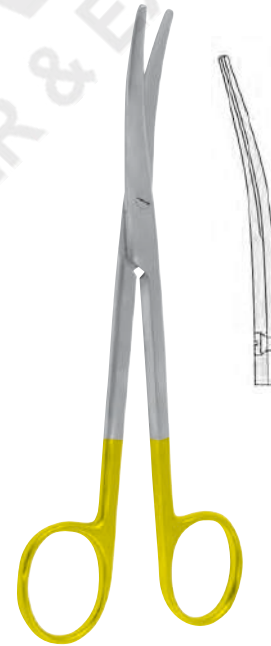

LEXER		
16,0 cm, 6"	$\frac{1}{4}$ "	011-141-16
21,0 cm, 8"	$\frac{1}{4}$ "	011-141-21

SURGICAL INSTRUMENTS

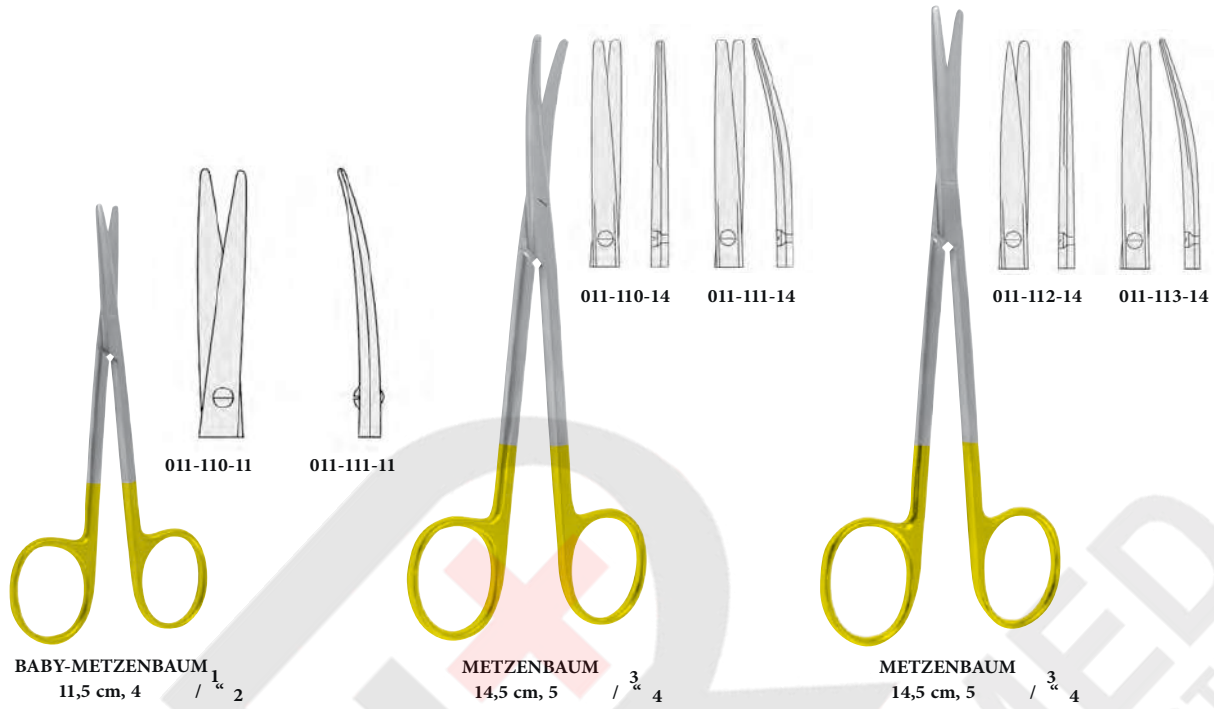

SURGICAL INSTRUMENTS

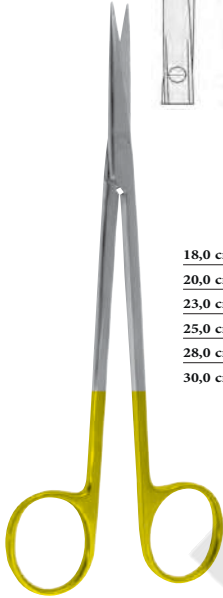
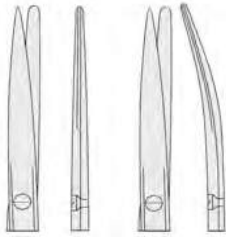

18,0 cm, 7"	011-112-18
20,0 cm, 8"	011-112-20
23,0 cm, 9"	011-112-23
25,0 cm, 10"	011-112-25
28,0 cm, 11"	011-112-28
30,0 cm, 12"	011-112-30

METZENBAUM

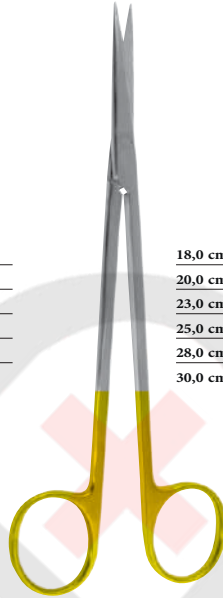
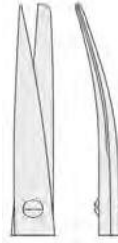

18,0 cm, 7"	011-113-18
20,0 cm, 8"	011-113-20
23,0 cm, 9"	011-113-23
25,0 cm, 10"	011-113-25
28,0 cm, 11"	011-113-28
30,0 cm, 12"	011-113-30

METZENBAUM

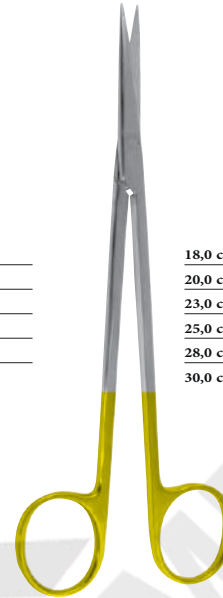
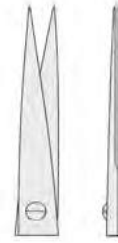

18,0 cm, 7"	011-114-18
20,0 cm, 8"	011-114-20
23,0 cm, 9"	011-114-23
25,0 cm, 10"	011-114-25
28,0 cm, 11"	011-114-28
30,0 cm, 12"	011-114-30

METZENBAUM

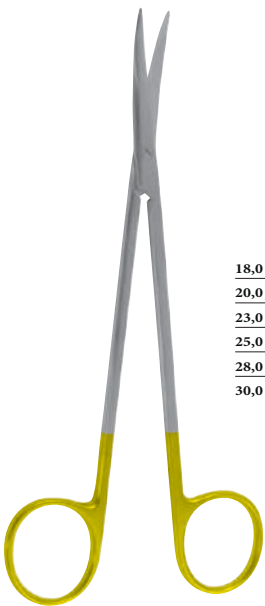
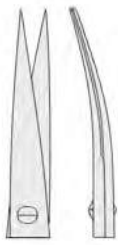

18,0 cm, 7"	011-115-18
20,0 cm, 8"	011-115-20
23,0 cm, 9"	011-115-23
25,0 cm, 10"	011-115-25
28,0 cm, 11"	011-115-28
30,0 cm, 12"	011-115-30

METZENBAUM



011-120-14 011-121-14

METZENBAUM-FINO $\frac{3}{4}$
 14,5 cm, 5 / 4



011-124-14 011-125-14

METZENBAUM-FINO $\frac{3}{4}$
 14,5 cm, 5 / 4

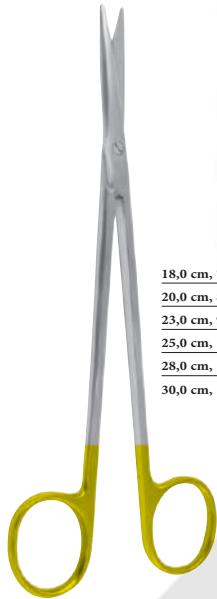

18,0 cm, 7"	011-120-18
20,0 cm, 8"	011-120-20
23,0 cm, 9"	011-120-23
25,0 cm, 10"	011-120-25
28,0 cm, 11"	011-120-28
30,0 cm, 12"	011-120-30

METZENBAUM-FINO

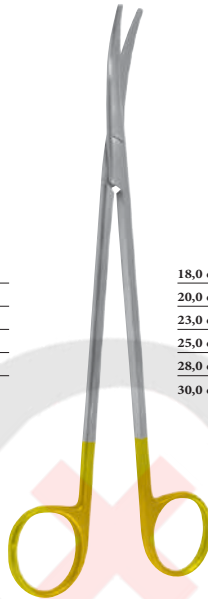

18,0 cm, 7"	011-121-18
20,0 cm, 8"	011-121-20
23,0 cm, 9"	011-121-23
25,0 cm, 10"	011-121-25
28,0 cm, 11"	011-121-28
30,0 cm, 12"	011-121-30

METZENBAUM-FINO

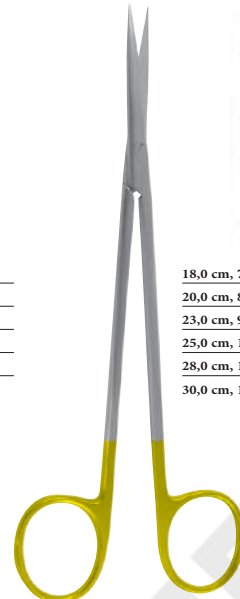

18,0 cm, 7"	011-124-18
20,0 cm, 8"	011-124-20
23,0 cm, 9"	011-124-23
25,0 cm, 10"	011-124-25
28,0 cm, 11"	011-124-28
30,0 cm, 12"	011-124-30

METZENBAUM-FINO

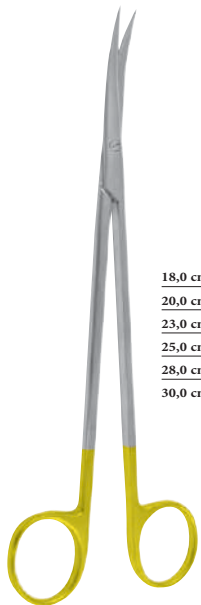

18,0 cm, 7"	011-125-18
20,0 cm, 8"	011-125-20
23,0 cm, 9"	011-125-23
25,0 cm, 10"	011-125-25
28,0 cm, 11"	011-125-28
30,0 cm, 12"	011-125-30

METZENBAUM-FINO



METZENBAUM-LAHEY
14,0 cm, 5 1/2"
011-137-14

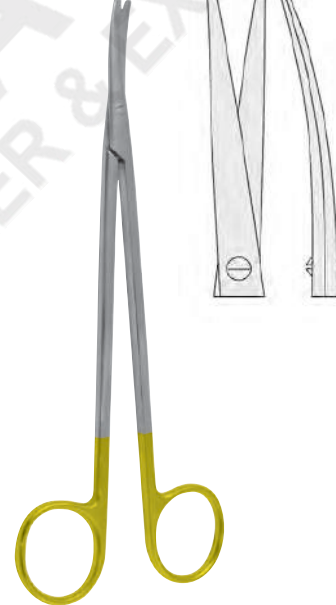

TOENNIS-ADSON
17,0 cm, 6 3/4"
011-139-17

Präparierscheren mit Hartmetallschneiden
 Dissecting Scissors with tungsten
 Carbide edges Tijeras para disección con
 Filos de carburo tungsteno Forbici per
 Dissezione con lame in carburo di tungsteno

ROCADA MED
 MANUFACTURER & EXPORTER

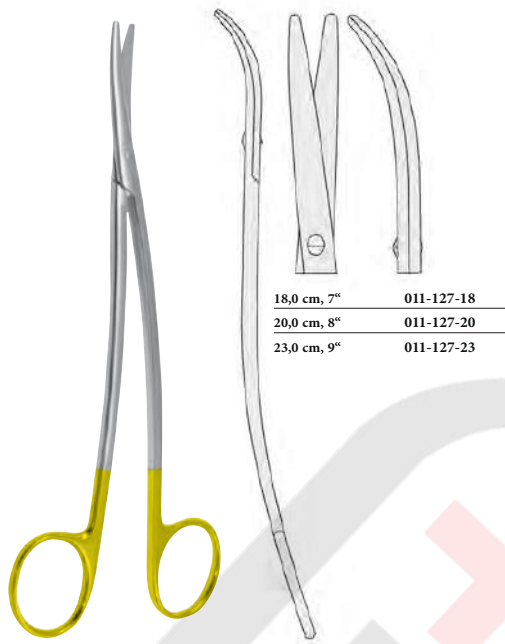

18,0 cm, 7"	011-127-18
20,0 cm, 8"	011-127-20
23,0 cm, 9"	011-127-23

METZENBAUM-FINO S

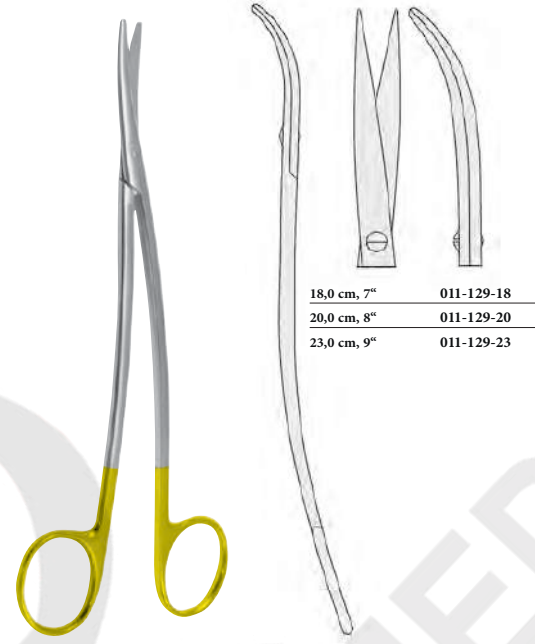

18,0 cm, 7"	011-129-18
20,0 cm, 8"	011-129-20
23,0 cm, 9"	011-129-23

METZENBAUM-FINO S

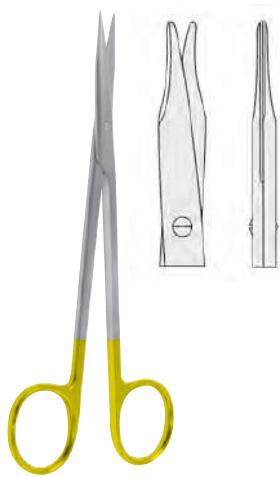

REYNOLDS
 15,0 cm, 6"
 011-210-15

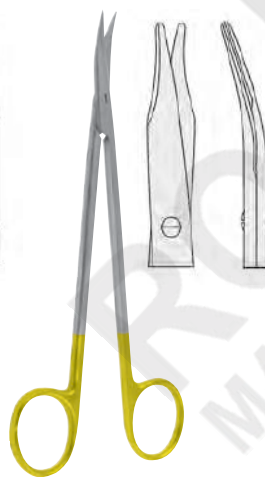

REYNOLDS
 15,0 cm, 6"
 011-211-15



HYSTEREKTOMY
 25,5 cm, 10"
 011-663-25



HYSTEREKTOMY
 25,0 cm, 9" ³/₄
 011-665-25

SURGICAL INSTRUMENTS

SURGICAL INSTRUMENTS



SIMS

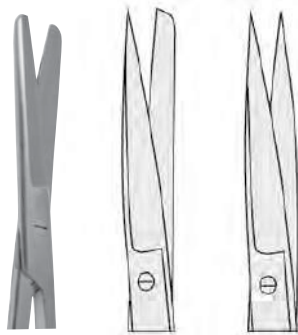

20,0 cm, 8"	011-600-20	01 1-602-20	01 1-604-20
23,0 cm, 9"	011-600-23	01 1-602-23	01 1-604-23



SIMS



20,0 cm, 8"	011-601-20	01 1-603-20	01 1-605-20
23,0 cm, 9"	011-601-23	01 1-603-23	01 1-605-23

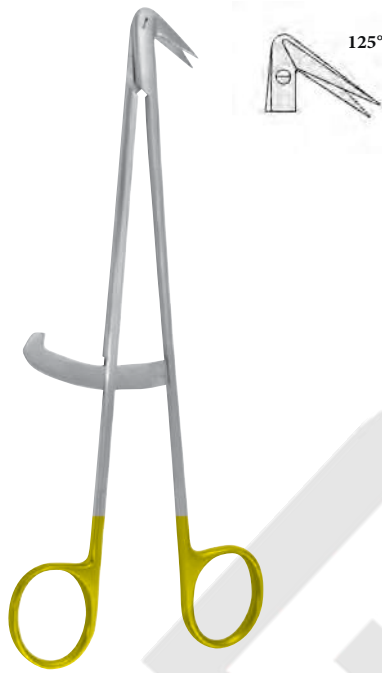

DIETRICH
 17,5 cm, 6 / $\frac{5}{8}$
 011-552-17

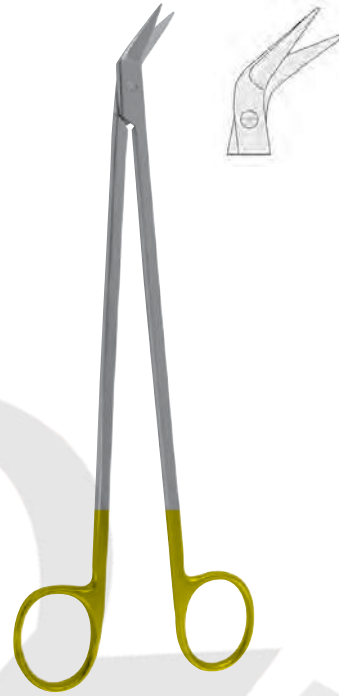

POTTS DE MARTEL
 24,0 cm, 9 / $\frac{1}{2}$
 011-548-24



DE BAKEY

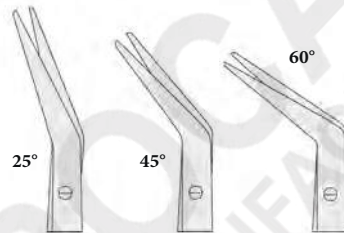

20,0 cm, 8"	011-543-25	01 1-543-45	01 1-543-60
23,0 cm, 9"	011-545-25	01 1-545-45	01 1-545-60

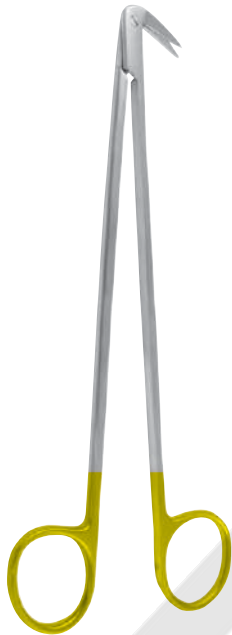

DIETHRICH-HEGEMANN
18,0 cm, 7"

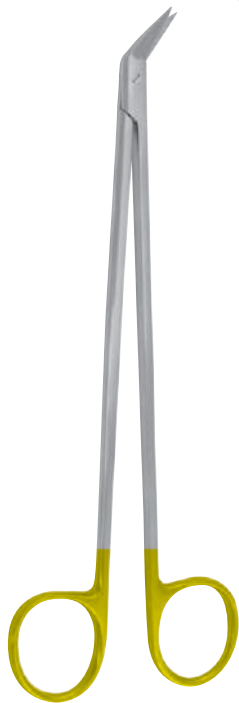

POTTS-SMITH
18,0 cm, 7" / 1 1/2"

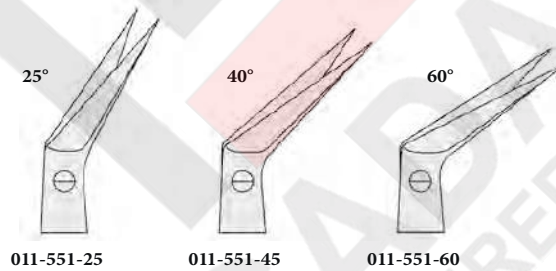

SURGICAL INSTRUMENTS



IRIS
 11,5 cm, 4 / $\frac{1}{4}$ 2

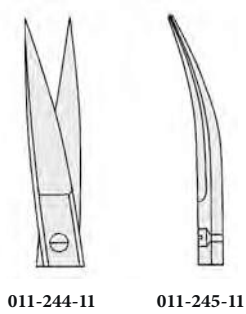

011-244-11 011-245-11



UNIVERSAL
 12,0 cm, 4 / $\frac{3}{4}$ 4
 011-800-12

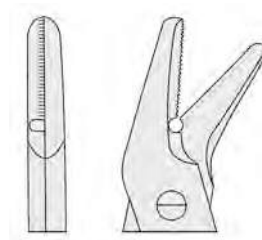

gezahnt
 serrated
 dentada
 dentata



LISTER
 18,0 cm, 7"
 011-900-18

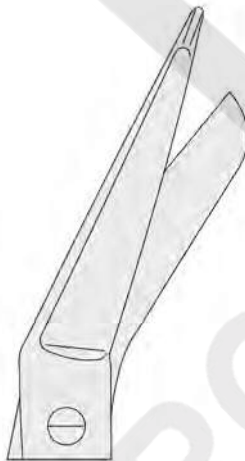

BRUNS
 24,0 cm, 9 / $\frac{1}{4}$ 2
 011-909-24



SURGICAL INSTRUMENTS

SURGICAL INSTRUMENTS

14,5 cm, 5 ³ / ₄ "	012-111-14
18,0 cm, 7"	012-111-18
20,0 cm, 8"	012-111-20
23,0 cm, 9"	012-111-23

14,5 cm, 5 ³ / ₄ "	012-121-14
18,0 cm, 7"	012-121-18
20,0 cm, 8"	012-121-20
23,0 cm, 9"	012-121-23

012-100-17 012-101-17

MAYO
17,0 cm, 6 ³/₄"

METZENBAUM

METZENBAUM-FINO

15,0 cm, 6"	012-129-15
19,0 cm, 7 ¹ / ₂ "	012-129-19

KAYE FACE LIFT

JABALEY
13,0 cm, 5"
012-130-13

TOENNIS-ADSON
17,0 cm, 6 ³/₄"
012-139-17

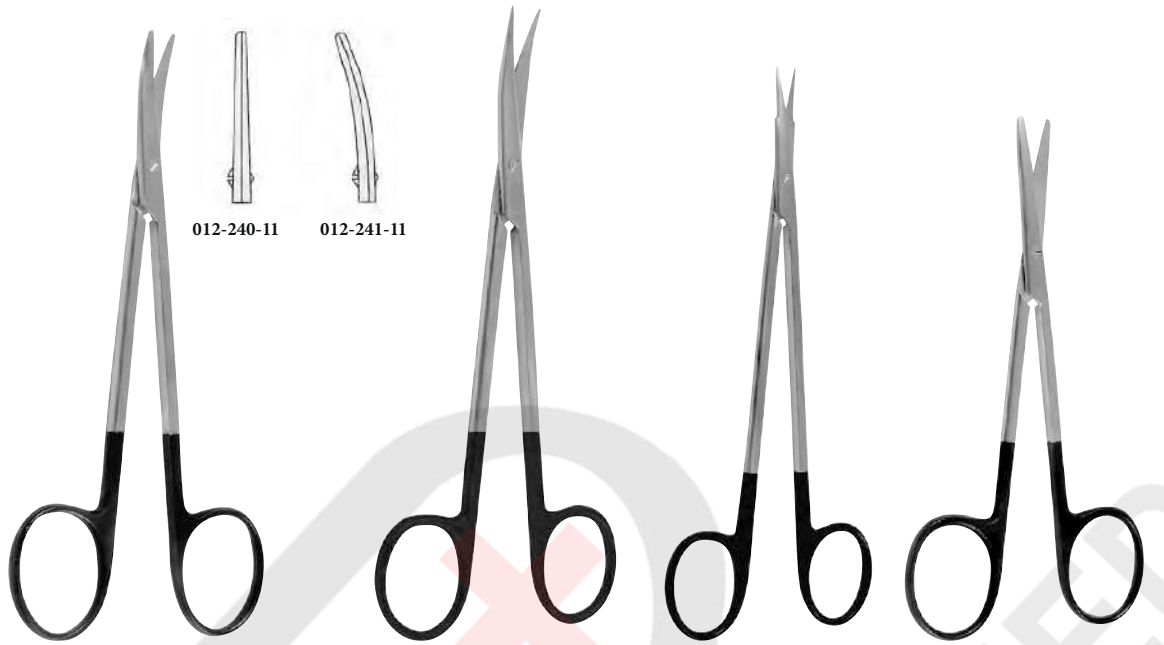

STRABISMUS
 11,5 cm, 4 / $\frac{1}{4}$ 2

JAMISON
 15,0 cm, 6" 012-218-15
 18,0 cm, 7" 012-218-18

REYNOLDS
 12,5 cm, 5" 012-210-12

BABY-METZENBAUM
 11,0 cm, 4 $\frac{3}{8}$ " 012-110-11
 14,5 cm, 5 $\frac{3}{4}$ " 012-110-14



IRIS
 11,0 cm, 4 / $\frac{3}{8}$ 8
 012-244-11

IRIS
 11,0 cm, 4 / $\frac{3}{8}$ 8
 012-245-11

STEVENS TENOTOMY
 11,0 cm, 4 / $\frac{3}{8}$ 8
 012-290-11

STEVENS T ENOTOMY
 11,0 cm, 4 / $\frac{3}{8}$ 8
 012-291-11

SURGICAL INSTRUMENTS

SURGICAL INSTRUMENTS



gerade
straight

PAR TYPE
12,0 cm, 4 / $\frac{3}{4}$ 4
012-200-12

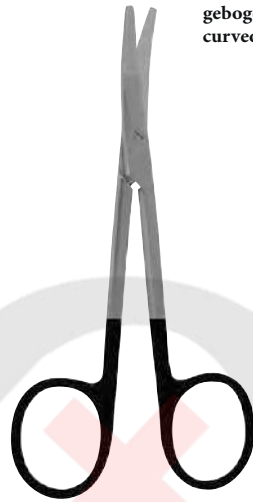

gebogen
curved

PAR TYPE
12,0 cm, 4 / $\frac{3}{4}$ 4
012-201-12

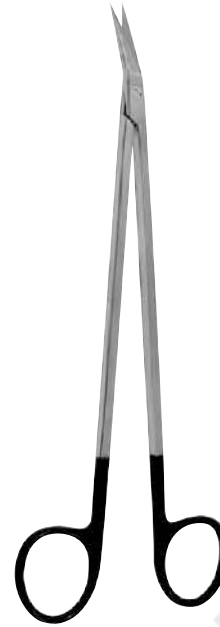

POTTS
19,0 cm, 7 / $\frac{1}{4}$ 2



25°

012-551-25



45°

012-551-45



60°

012-551-60

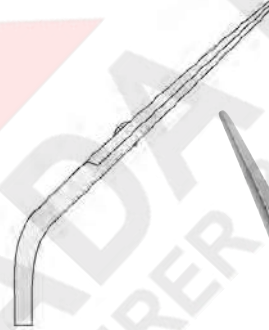

FOMON
14,5 cm, 5 / $\frac{3}{4}$ 4
012-343-15



COTTLE
16,5 cm, 6 / $\frac{1}{4}$ 2
012-511-16

gezahnt
serrated
dentada
dentata

Mikro-Präparierscheren
Micro-dissecting scissors
Micro-tijeras de disección
Micro-forbici per dissezione

018-081-11

018-083-11

018-246-01

018-246-02

018-246-03

WESTCOTT
11,0 cm, 4 / $\frac{3}{8}$

GOMEL		HEPP SCHEIDEL	
14,0 cm, 5	$\frac{1}{2}$ "	14,0 cm, 5	$\frac{1}{2}$ "
16,0 cm, 6	$\frac{3}{4}$ "	16,0 cm, 6	$\frac{3}{4}$ "
018-241-14Z		018-243-14	
018-241-16Z		018-243-16	

18,5 cm, 7 / $\frac{1}{4}$ 4



STEVENS

18,5 cm, 7	$\frac{1}{4}$ "	018-290-01	018-290-02	018-290-03	018-290-04
22,5 cm, 8	$\frac{3}{4}$ "	018-291-01	018-291-02	018-291-03	018-291-04
18,5 cm, 7	$\frac{1}{4}$ "	018-292-01	018-292-02		
22,5 cm, 8	$\frac{3}{4}$ "	018-293-01	018-293-02		

SURGICAL INSTRUMENTS



18,0 cm, 7"



018-270-25



018-270-45

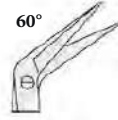

018-270-60

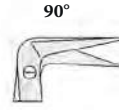

018-270-90



018-270-12



018-271-25

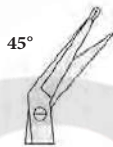

018-271-45

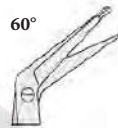

018-271-60

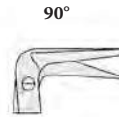

018-271-90



018-271-12



15,0 cm, 6"
018-223-15



15,0 cm, 6"
018-223-15Z



gezahnt
serrated
dentada
dentata



15,0 cm, 6"
018-201-15



18,0 cm, 7"
018-201-18

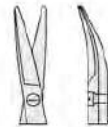



15,0 cm, 6"
018-232-15

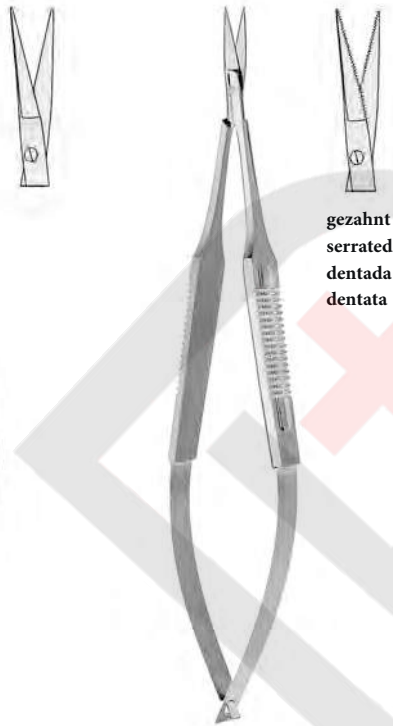

15,0 cm, 6"
018-232-15Z



15,0 cm, 6"
018-203-15



18,0 cm, 7"
018-203-18

SURGICAL INSTRUMENTS

SURGICAL INSTRUMENTS



STANDARD

10,5 cm, 4	1/8"	020-002-10
11,5 cm, 4	1/2"	020-002-11
13,0 cm, 5"		020-002-13
14,5 cm, 5	3/4"	020-002-14
15,0 cm, 6"		020-002-15
16,0 cm, 6	1/4"	020-002-16
18,0 cm, 7"		020-002-18
20,0 cm, 8"		020-002-20
25,0 cm, 10"		020-002-25
30,0 cm, 12"		020-002-30

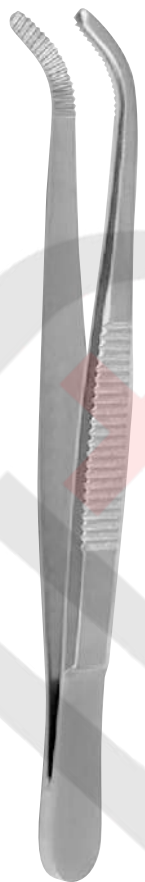

schmal
narrow
estrechos
stretti

STANDARD

10,5 cm, 4	1/8"	020-003-10
11,5 cm, 4	1/2"	020-003-11
13,0 cm, 5"		020-003-13
14,5 cm, 5	3/4"	020-003-14
15,0 cm, 6"		020-003-15
16,0 cm, 6	1/4"	020-003-16
18,0 cm, 7"		020-003-18
20,0 cm, 8"		020-003-20
25,0 cm, 10"		020-003-25
30,0 cm, 12"		020-003-30



schmal
narrow
estrechos
stretti

STANDARD

10,5 cm, 4	1/8"	020-004-10
11,5 cm, 4	1/2"	020-004-11
13,0 cm, 5"		020-004-13
14,5 cm, 5	3/4"	020-004-14
15,0 cm, 6"		020-004-15
16,0 cm, 6	1/4"	020-004-16
18,0 cm, 7"		020-004-18
20,0 cm, 8"		020-004-20
25,0 cm, 10"		020-004-25
30,0 cm, 12"		020-004-30



fein
fine
finas
fini

STANDARD

10,5 cm, 4	1/8"	020-010-10
11,5 cm, 4	1/2"	020-010-11
13,0 cm, 5"		020-010-13
14,5 cm, 5	3/4"	020-010-14
15,0 cm, 6"		020-010-15
16,0 cm, 6	1/4"	020-010-16
18,0 cm, 7"		020-010-18
20,0 cm, 8"		020-010-20
25,0 cm, 10"		020-010-25
30,0 cm, 12"		020-010-30



fein
fine
finas
fini
Т О Н К И Е



fein
fine
finas
fini

mit Stift
with pin
con perno
con espiga

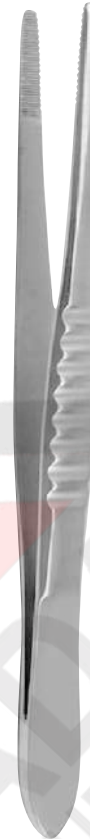

schmal
narrow
estrechos
stretti
у з к и е



10,5 cm, 4	$\frac{1}{8}''$	020-011-10
11,5 cm, 4	$\frac{1}{2}''$	020-011-11
13,0 cm, 5"		020-011-13
14,5 cm, 5	$\frac{3}{4}''$	020-011-14
16,0 cm, 6	$\frac{1}{4}''$	020-011-16
18,0 cm, 7"		020-011-18
20,0 cm, 8"		020-011-20
25,0 cm, 10"		020-011-25
30,0 cm, 12"		020-011-30

10,5 cm, 4	$\frac{1}{8}''$	020-018-10
11,5 cm, 4	$\frac{1}{2}''$	020-018-11
13,0 cm, 5"		020-018-13
14,5 cm, 5	$\frac{3}{4}''$	020-018-14
16,0 cm, 6	$\frac{1}{4}''$	020-018-16
18,0 cm, 7"		020-018-18
20,0 cm, 8"		020-018-20
25,0 cm, 10"		020-018-25
30,0 cm, 12"		020-018-30

MOD. USA		
12,0 cm, 4	$\frac{3}{4}''$	020-006-10
13,0 cm, 5"		020-006-13
14,5 cm, 5	$\frac{3}{4}''$	020-006-14
15,0 cm, 6"		020-006-15
18,0 cm, 7"		020-006-18
20,0 cm, 8"		020-006-20
25,5 cm, 10"		020-006-25
30,0 cm, 12"		020-006-30

MOD. USA		
12,0 cm, 4	$\frac{3}{4}''$	020-012-11
13,0 cm, 5"		020-012-13
14,5 cm, 5	$\frac{3}{4}''$	020-012-14
15,0 cm, 6"		020-012-15
18,0 cm, 7"		020-012-18
20,0 cm, 8"		020-012-20
25,5 cm, 10"		020-012-25

SURGICAL INSTRUMENTS

SURGICAL INSTRUMENTS



ADSON
12,0 cm, 4 ³/₄" 020-070-12
15,0 cm, 6" 020-070-15



MICRO-ADSON
12,0 cm, 4 ³/₄" 020-076-12
15,0 cm, 6" 020-076-15



STILLE
15,0 cm, 6" 020-008-15



MC INDOE
15,0 cm, 6" 020-158-15



TAYLOR
17,5 cm, 6 ⁵/₈" 020-114-17



TAYLOR
17,5 cm, 6 ⁵/₈" 020-115-17



TAYLOR
18,5 cm, 7 ¹/₄" 020-117-18



GERALD
18,0 cm, 7" 020-102-18



GERALD
 18,0 cm, 7"
 020-103-18



POTTS-SMITH

18,0 cm, 7"	020-026-18
21,0 cm, 8 1/4"	020-026-21
25,0 cm, 10"	020-026-25



POTTS-SMITH

18,0 cm, 7"	020-027-18
21,0 cm, 8 1/4"	020-027-21
25,0 cm, 10"	020-027-25



SEMKEN

12,5 cm, 5"	020-040-12
15,0 cm, 6"	020-040-15



CUSHING

17,5 cm, 6 5/8"	020-092-17
-----------------	------------



CUSHING

17,5 cm, 6 5/8"	020-093-17
-----------------	------------



BROPHY

20,0 cm, 8"	020-094-20
-------------	------------

SURGICAL INSTRUMENTS



BROPHY
20,0 cm, 8"
020-095-20



BONNEY
18,0 cm, 7"
020-120-18



SINGLE-TUTTLE
23,0 cm, 9"
020-516-23



DENNIS BROWN
20,0 cm, 8"
020-126-20



DUEHRSSSEN
20,0 cm, 8"
020-470-20



WAUGH
15,0 cm, 6" 020-130-15
20,0 cm, 8" 020-130-20



RAMSEY
18,0 cm, 7"
020-136-18

1 x 2



2 x 3



3 x 4



4 x 5



STANDARD

10,5 cm, 4	1/8"	020-200-10
11,5 cm, 4	1/2"	020-200-11
13,0 cm, 5"		020-200-13
14,5 cm, 5	3/4"	020-200-14
15,0 cm, 6"		020-200-15
16,0 cm, 6	1/4"	020-200-16
18,0 cm, 7"		020-200-18
20,0 cm, 8"		020-200-20
25,0 cm, 10"		020-200-25
30,0 cm, 12"		020-200-30

11,5 cm, 4	1/2"	020-252-11
13,0 cm, 5"		020-252-13
14,5 cm, 5	3/4"	020-252-14
16,0 cm, 6	1/4"	020-252-16
18,0 cm, 7"		020-252-18
20,0 cm, 8"		020-252-20
25,0 cm, 10"		020-252-25
30,0 cm, 12"		020-252-30

13,0 cm, 5"		020-254-13
14,5 cm, 5	3/4"	020-254-14
16,0 cm, 6	1/4"	020-254-16
18,0 cm, 7"		020-254-18
20,0 cm, 8"		020-254-20

13,0 cm, 5"		020-256-13
14,5 cm, 5	3/4"	020-256-14
16,0 cm, 6	1/4"	020-256-16
18,0 cm, 7"		020-256-18
20,0 cm, 8"		020-256-20

SURGICAL INSTRUMENTS

fein
fine
finas
fini

mit Stift
with pin
con perno
con espiga

mit Stift
with pin
con perno
con espiga

englische Modelle
english patterns
modelos ingleses
modelli inglese

1 x 2



13,0 cm, 5"	020-210-13
14,5 cm, 5 3/4"	020-210-14
15,5 cm, 6"	020-210-15
16,0 cm, 6 1/4"	020-210-16
18,0 cm, 7"	020-210-18
20,0 cm, 8"	020-210-20
25,0 cm, 10"	020-210-25
30,0 cm, 12"	020-210-30

1 x 2



13,0 cm, 5"	020-218-13
14,5 cm, 5 3/4"	020-218-14
15,5 cm, 6"	020-218-15
16,0 cm, 6 1/4"	020-218-16
18,0 cm, 7"	020-218-18
20,0 cm, 8"	020-218-20
25,0 cm, 10"	020-218-25
30,0 cm, 12"	020-218-30

1 x 2



13,0 cm, 5"	020-219-13
14,5 cm, 5 3/4"	020-219-14
16,0 cm, 6 1/4"	020-219-16
18,0 cm, 7"	020-219-18
20,0 cm, 8"	020-219-20

1 x 2



13,0 cm, 5"	020-236-13
14,5 cm, 5 3/4"	020-236-14
15,0 cm, 6"	020-236-15

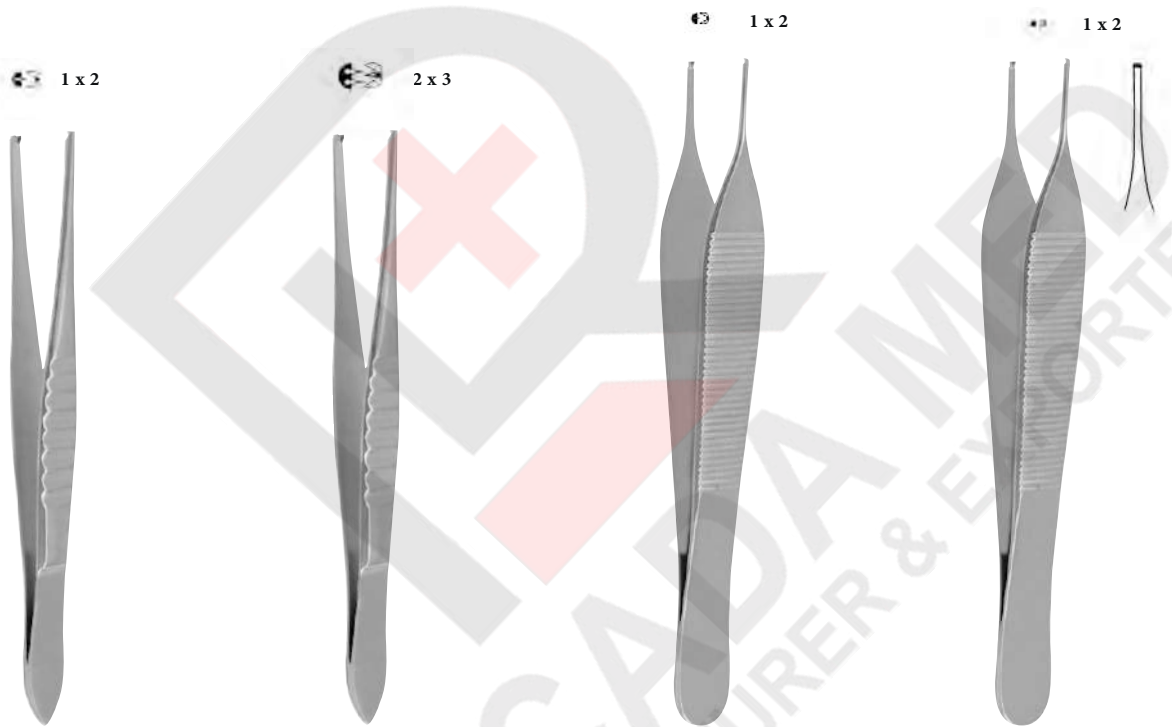

MOD. USA

12,0 cm, 4	3/4"	020-206-12
13,0 cm, 5"		020-206-13
14,5 cm, 5	3/4"	020-206-14
15,5 cm, 6"		020-206-15
18,0 cm, 7"		020-206-18
20,0 cm, 8"		020-206-20
25,0 cm, 10"		020-206-25
30,0 cm, 12"		020-206-30

MOD. USA

12,0 cm, 4	3/4"	020-212-12
13,0 cm, 5"		020-212-13
14,5 cm, 5	3/4"	020-212-14
15,5 cm, 6"		020-212-15
18,0 cm, 7"		020-212-18
20,0 cm, 8"		020-212-20
25,0 cm, 10"		020-212-25
30,0 cm, 12"		020-212-30

ADSON

12,0 cm, 4	3/4"	020-270-12
15,0 cm, 6"		020-270-15

MICRO-ADSON

12,0 cm, 4	3/4"	020-276-12
15,0 cm, 6"		020-276-15

SURGICAL INSTRUMENTS

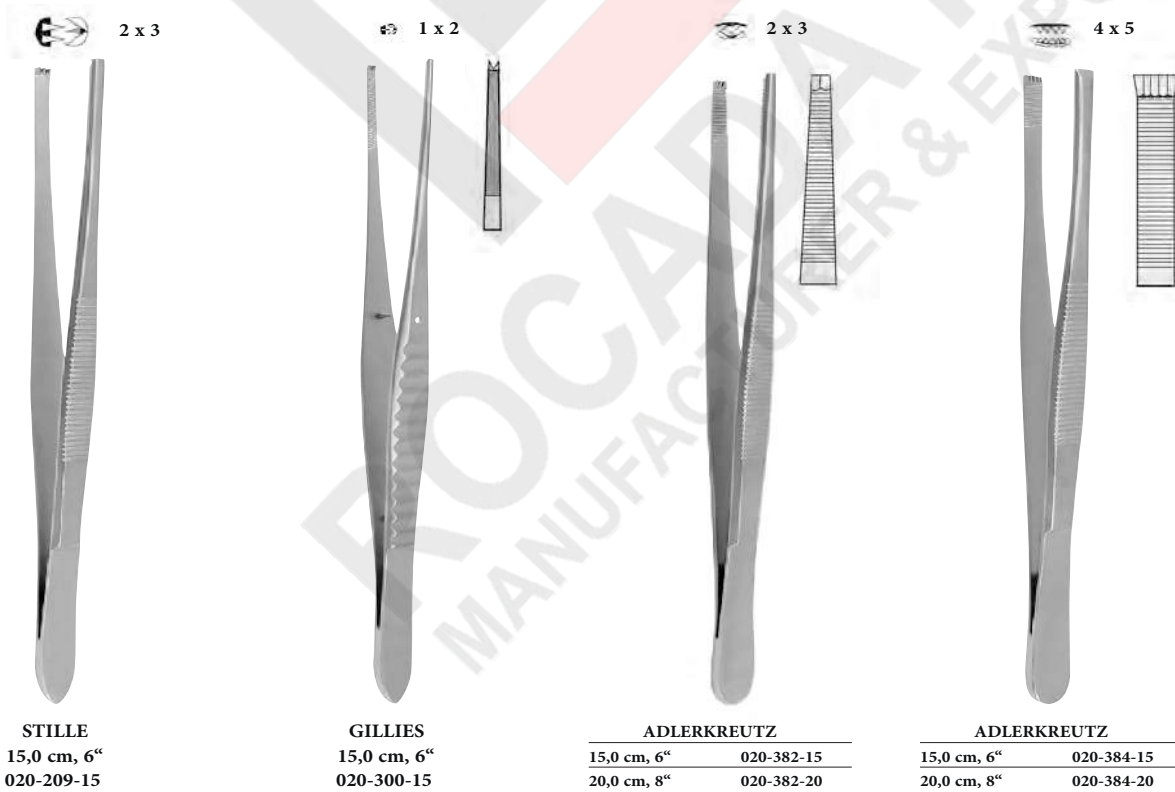
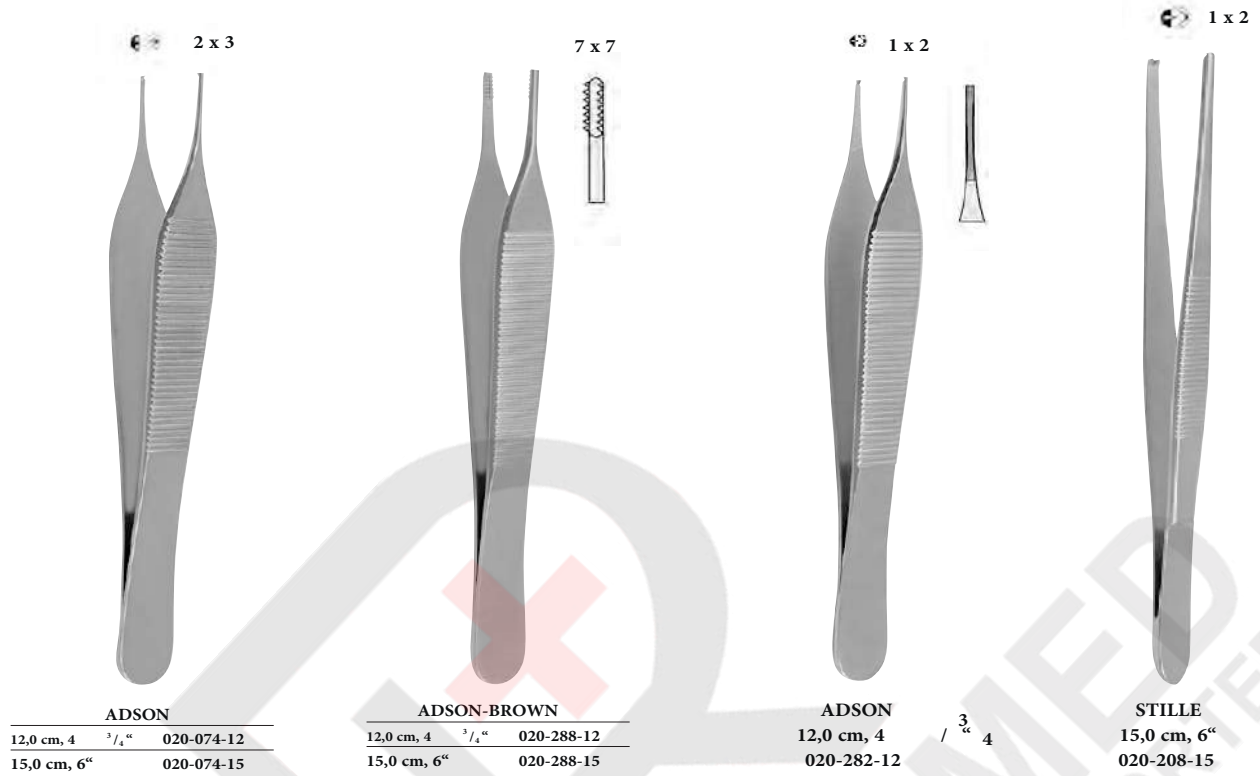

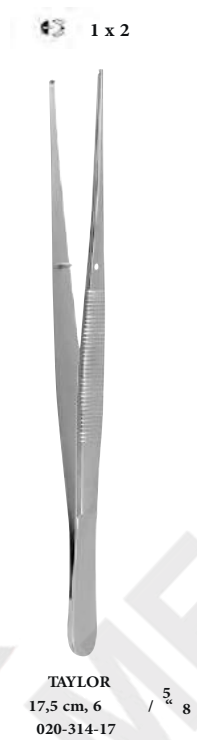

SURGICAL INSTRUMENTS

SURGICAL INSTRUMENTS

1 x 2



CUSHING
17,5 cm, 6" / 5/8"
020-292-17

1 x 2



CUSHING
17,5 cm, 6" / 5/8"
020-293-17

1 x 2



POTTS-SMITH

18,0 cm, 7"	020-226-18
21,0 cm, 8 1/4"	020-226-21
25,0 cm, 10"	020-226-25

1 x 2



WAUGH

15,0 cm, 6"	020-330-15
20,0 cm, 8"	020-330-20

1 x 2



BROPHY
20,0 cm, 8"
020-294-20



RUSS. MODELL

15,0 cm, 6"	020-456-15
20,0 cm, 8"	020-456-20
25,0 cm, 10"	020-456-25

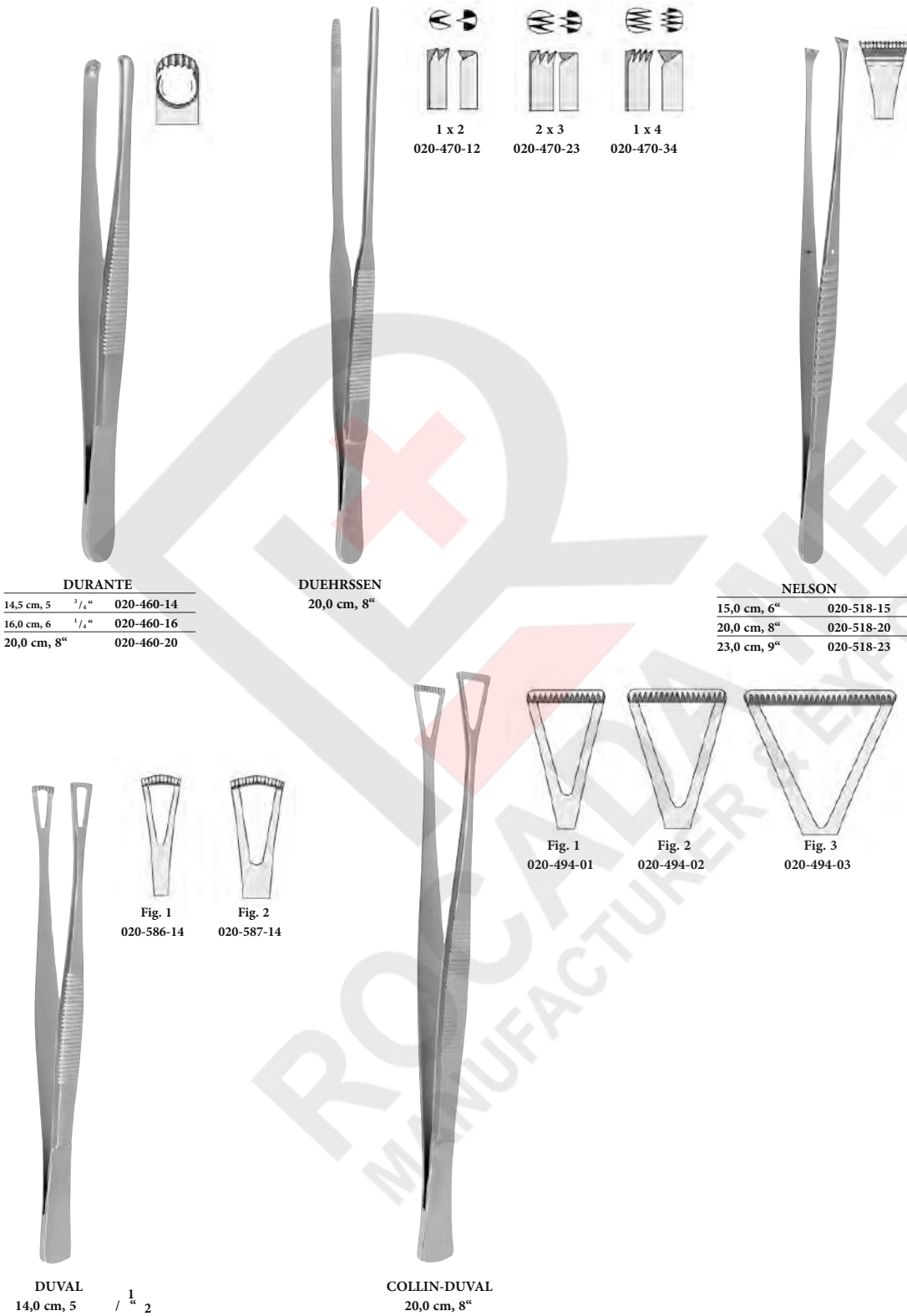

SURGICAL INSTRUMENTS

SURGICAL INSTRUMENTS

 <p>1 x 2</p>	 <p>2 x 3</p>	 <p>7 x 7</p>	 <p>1 x 2</p>																						
<p>LANE</p> <table border="0"> <tr> <td>14,5 cm, 5"</td> <td>3/4"</td> <td>020-420-14</td> </tr> <tr> <td>20,0 cm, 8"</td> <td></td> <td>020-420-20</td> </tr> </table>	14,5 cm, 5"	3/4"	020-420-14	20,0 cm, 8"		020-420-20	<p>LANE</p> <table border="0"> <tr> <td>14,5 cm, 5"</td> <td>3/4"</td> <td>020-422-14</td> </tr> <tr> <td>20,0 cm, 8"</td> <td></td> <td>020-422-20</td> </tr> </table>	14,5 cm, 5"	3/4"	020-422-14	20,0 cm, 8"		020-422-20	<p>BROWN</p> <table border="0"> <tr> <td>15,0 cm, 6"</td> <td>020-410-15</td> </tr> <tr> <td>20,0 cm, 8"</td> <td>020-410-20</td> </tr> <tr> <td>25,0 cm, 10"</td> <td>020-410-25</td> </tr> </table>	15,0 cm, 6"	020-410-15	20,0 cm, 8"	020-410-20	25,0 cm, 10"	020-410-25	<p>TREVES</p> <table border="0"> <tr> <td>13,0 cm, 5"</td> <td>020-510-13</td> </tr> <tr> <td>15,0 cm, 6"</td> <td>020-510-15</td> </tr> </table>	13,0 cm, 5"	020-510-13	15,0 cm, 6"	020-510-15
14,5 cm, 5"	3/4"	020-420-14																							
20,0 cm, 8"		020-420-20																							
14,5 cm, 5"	3/4"	020-422-14																							
20,0 cm, 8"		020-422-20																							
15,0 cm, 6"	020-410-15																								
20,0 cm, 8"	020-410-20																								
25,0 cm, 10"	020-410-25																								
13,0 cm, 5"	020-510-13																								
15,0 cm, 6"	020-510-15																								
 <p>1 x 2</p>	 <p>2 x 3</p>	 <p>1 x 2</p>	 <p>2 x 3</p>																						
<p>RAMSEY</p> <table border="0"> <tr> <td>18,0 cm, 7"</td> <td>020-520-18</td> </tr> </table>	18,0 cm, 7"	020-520-18	<p>RAMSEY</p> <table border="0"> <tr> <td>18,0 cm, 7"</td> <td>020-522-18</td> </tr> </table>	18,0 cm, 7"	020-522-18	<p>RAMSEY</p> <table border="0"> <tr> <td>18,0 cm, 7"</td> <td>020-590-18</td> </tr> </table>	18,0 cm, 7"	020-590-18	<p>RAMSEY</p> <table border="0"> <tr> <td>18,0 cm, 7"</td> <td>020-592-18</td> </tr> </table>	18,0 cm, 7"	020-592-18														
18,0 cm, 7"	020-520-18																								
18,0 cm, 7"	020-522-18																								
18,0 cm, 7"	020-590-18																								
18,0 cm, 7"	020-592-18																								

mit Stift
with pin
con perno
con espiga

mit Stift
with pin
con perno
con espiga



8,0 cm, 3	1/4"	020-662-08
9,0 cm, 3	1/2"	020-662-09
10,5 cm, 4	1/8"	020-662-10
11,5 cm, 4	1/2"	020-662-11
13,0 cm, 5"		020-662-13
14,5 cm, 5	1/2"	020-662-14

8,0 cm, 3	1/4"	020-663-08
9,0 cm, 3	1/2"	020-663-09
10,5 cm, 4	1/8"	020-663-10
11,5 cm, 4	1/2"	020-663-11
13,0 cm, 5"		020-663-13
14,5 cm, 5	1/2"	020-663-14

8,0 cm, 3	1/4"	020-666-08
9,0 cm, 3	1/2"	020-666-09
10,5 cm, 4	1/8"	020-666-10
11,5 cm, 4	1/2"	020-666-11
13,0 cm, 5"		020-666-13
14,5 cm, 5	1/2"	020-666-14

8,0 cm, 3	1/4"	020-667-08
9,0 cm, 3	1/2"	020-667-09
10,5 cm, 4	1/8"	020-667-10
11,5 cm, 4	1/2"	020-667-11
13,0 cm, 5"		020-667-13
14,5 cm, 5	1/2"	020-667-14

SURGICAL INSTRUMENTS

SURGICAL INSTRUMENTS



HUNTER
10,5 cm, 4 / $\frac{1}{4}$
020-652-10



HUNTER
10,5 cm, 4 / $\frac{1}{4}$
020-653-10



WALTER-CARMALT
10,5 cm, 4 / $\frac{1}{4}$
020-656-10



WALTER-CARMALT
10,5 cm, 4 / $\frac{1}{4}$
020-657-10



FEILCHENFELD
7,5 cm, 3 / $\frac{1}{8}$ 020-650-07
9,0 cm, 3 / $\frac{1}{2}$ 020-650-09
11,5 cm, 4 / $\frac{1}{2}$ 020-650-11



10,0 cm, 4"
020-806-10



10,0 cm, 4"
020-807-10



GRAEFE
10,0 cm, 4[°]
020-810-10



GRAEFE
10,0 cm, 4[°]
020-811-10



GRAEFE
10,0 cm, 4[°]
020-813-10



GRAEFE
10,0 cm, 4[°]
020-814-10



GRAEFE
10,0 cm, 4[°]
020-815-10



GRAEFE
10,0 cm, 4[°]
020-817-10

SURGICAL INSTRUMENTS

SURGICAL INSTRUMENTS



0,3 mm x 45°

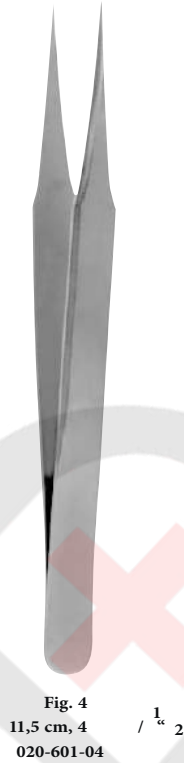

0,3 mm x 90°



0,3 mm



0,3 mm x 45°

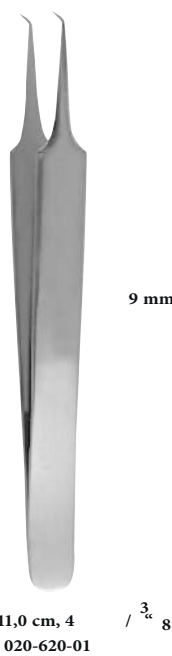

9 mm

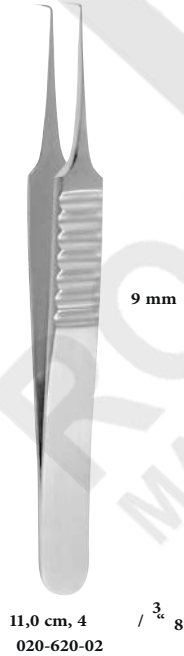

9 mm



9 mm

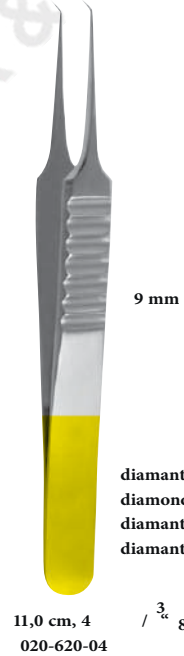

9 mm

diamantbeschichtet
diamond coated
diamantato
diamantato



DE BAKEY

1,5 mm 2,0 mm 2,4 mm 2,8 mm



16,0 cm, 6 1/4"	020-700-16	020-702-16	020-704-16	020-706-16
20,0 cm, 8"	020-700-20	020-702-20	020-704-20	020-706-20
24,0 cm, 9 1/2"	020-700-24	020-702-24	020-704-24	020-706-24
30,0 cm, 12"	020-700-30	020-702-30	020-704-30	020-706-30

2,8 mm 3,5 mm 3,5 mm



16,0 cm, 6 1/4"	020-716-16	020-708-16	020-718-16
20,0 cm, 8"	020-716-20	020-708-20	020-718-20
24,0 cm, 9 1/2"	020-716-24	020-708-24	020-718-24
30,0 cm, 12"	020-716-30	020-708-30	020-718-30



DE BAKEY

1,5 mm 2,0 mm



16,0 cm, 6 1/4"	020-701-16	020-703-16
20,0 cm, 8"	020-701-20	020-703-20
24,0 cm, 9 1/2"	020-701-24	020-703-24
30,0 cm, 12"	020-701-30	020-703-30

SURGICAL INSTRUMENTS

SURGICAL INSTRUMENTS



STANDARD

14,5 cm, 5 ^{3/4} "	021-200-14
16,0 cm, 6 ^{1/4} "	021-200-16
18,0 cm, 7"	021-200-18
20,0 cm, 8"	021-200-20
25,0 cm, 10"	021-200-25
30,0 cm, 12"	021-200-30



STANDARD

14,0 cm, 5 ^{1/2} "	021-208-14
16,0 cm, 6 ^{1/4} "	021-208-16
18,0 cm, 7"	021-208-18
20,0 cm, 8"	021-208-20
25,0 cm, 10"	021-208-25
30,0 cm, 12"	021-208-30



STANDARD

12,5 cm, 5"	021-040-12
15,0 cm, 6"	021-040-15



STANDARD

15,0 cm, 6"	021-140-15
23,0 cm, 9"	021-140-23
25,0 cm, 10"	021-140-25



GILLIES
 15,0 cm, 6"
 021-300-15



MC INDOE
 15,0 cm, 6"
 021-158-15



GERALD
 17,0 cm, 6 / 3/4

021-102-17



021-302-17



POTTS-SMITH

15,0 cm, 6"	021-026-15
18,0 cm, 7"	021-026-18
20,0 cm, 8"	021-026-20



BONNEY
 17,5 cm, 6 / 5/8
 021-590-17



CUSHING
 17,5 cm, 6 / 5/8



021-092-17



021-093-17



CUSHING-TAYLOR
 18,0 cm, 7"
 021-117-18



ADSON
 17,5 cm, 6 / 5/8

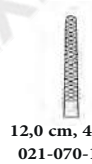

12,0 cm, 4 / 3/4
 021-070-12



12,0 cm, 4 / 3/4
 021-270-12



15,0 cm, 6"
 021-070-15



15,0 cm, 6"
 021-270-15



SCHAEDEL
9,0 cm, 3 / 1/4" 2
030-101-09



ENGL. MODELL
9,0 cm, 3 / 1/4" 2
030-109-09



JONES	
5,0 cm, 2"	030-105-05
7,0 cm, 2 3/4"	030-105-07
9,0 cm, 3 1/2"	030-105-09



JONES
9,0 cm, 3 / 1/4" 2
030-107-09

mit Schlauch- oder Kabelhalter
with clip for tubing or cable
con porta-tubo o porta-cable
con porta-tubo o porta-cavo



BACKHAUS	
9,0 cm, 3 1/2"	030-000-09
11,0 cm, 4 3/8"	030-000-11
13,0 cm, 5"	030-000-13
15,0 cm, 6"	030-000-15



11,0 cm, 4 3/8" 8
030-005-11



ROEDER
13,0 cm, 5" 8
030-010-13



ROEDER
15,0 cm, 5"
030-010-15



BERNHARD
16,5 cm, 6" / 1/2"
030-044-16



Kugel / Pfanne
Ball / Socket
Bola / Cojinete
Palla / Cuscinetto

13,0 cm, 5"
030-024-13

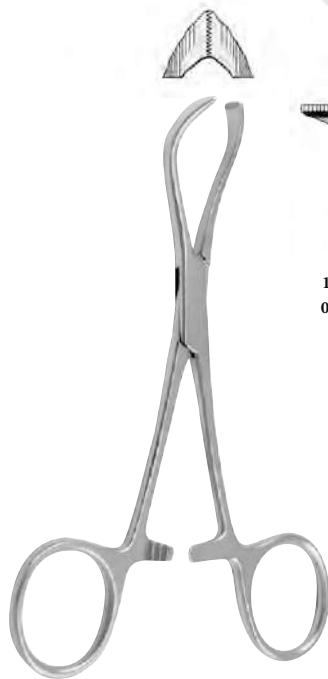

LORNA



10,0 cm, 4"
030-014-10

13,0 cm, 5"
030-014-13



LANE

15,0 cm, 6"	030-040-15
18,0 cm, 7"	030-040-18
20,0 cm, 8"	030-040-20

SURGICAL INSTRUMENTS

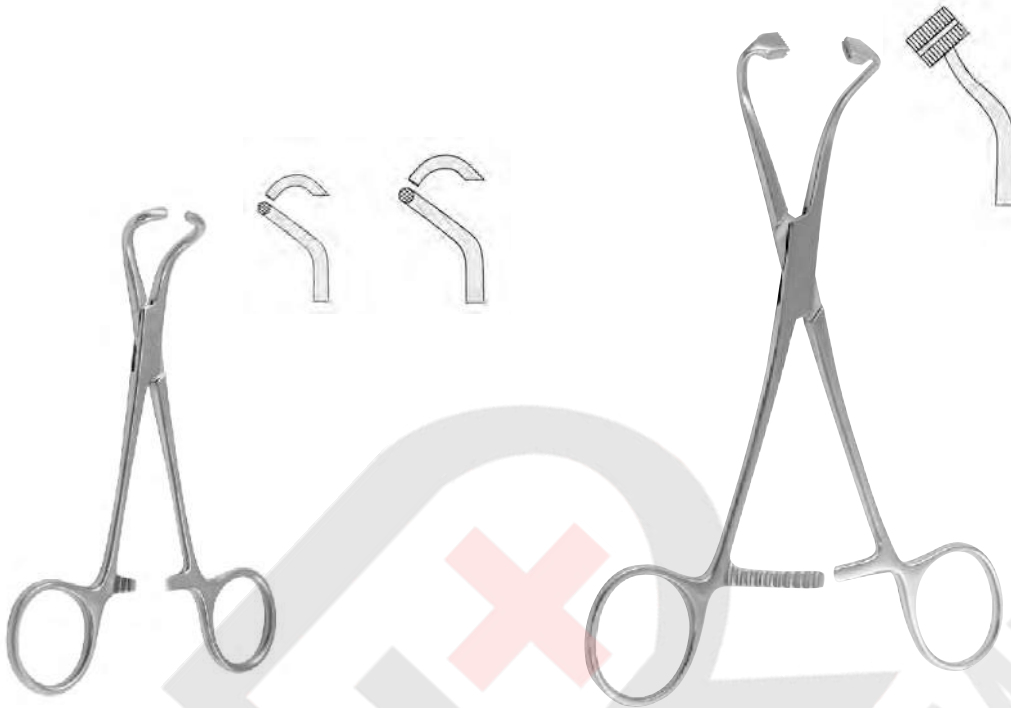

LISTER

13,0 cm, 5"	030-360-13
16,0 cm, 6 1/4"	030-360-16
18,0 cm, 7"	030-360-18



BRYANT

13,0 cm, 5"	030-351-13
-------------	------------



BOZEMANN

26,0 cm, 10 1/4"	030-320-26
------------------	------------

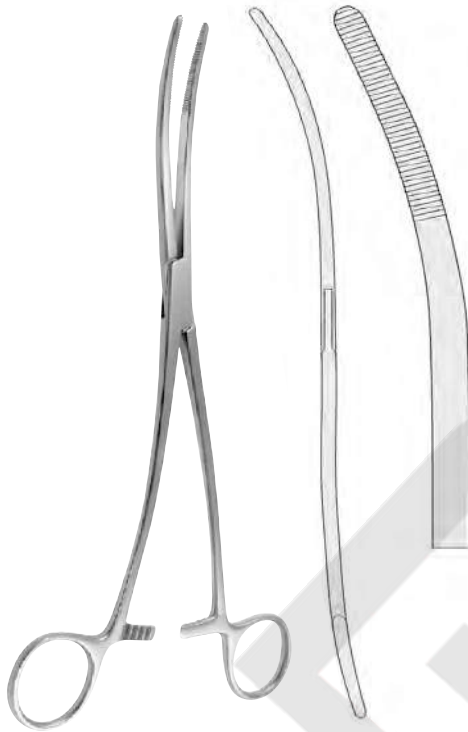

BOZEMANN
 26,0 cm, 10 / $\frac{3}{4}$
 030-321-26

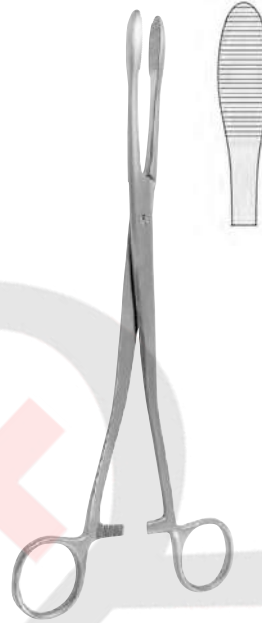

COLLIN
 25,0 cm, 9 / $\frac{3}{4}$
 030-300-25



CHERON
 25,0 cm, 9 / $\frac{3}{4}$
 030-303-25



PELKMANN
 25,0 cm, 9 / $\frac{3}{4}$

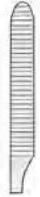

030-310-25



030-311-25



ULRICH

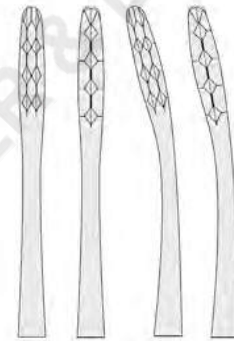

22,0 cm, 8	$\frac{5}{8}$ "	030-200-22	030-201-22
25,0 cm, 9	$\frac{3}{4}$ "	030-200-25	030-201-25
27,0 cm, 10	$\frac{5}{8}$ "	030-200-27	030-201-27

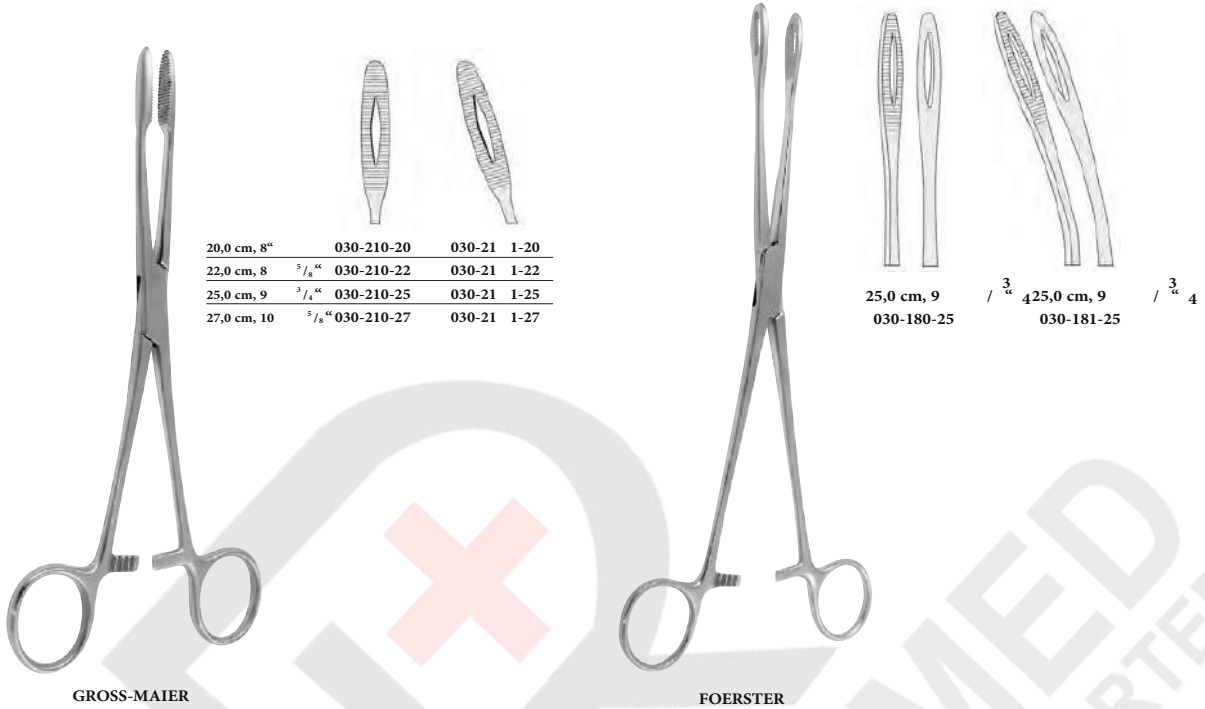

20,0 cm, 8"	030-210-20	030-21	1-20
22,0 cm, 8 5/8"	030-210-22	030-21	1-22
25,0 cm, 9 3/4"	030-210-25	030-21	1-25
27,0 cm, 10 5/8"	030-210-27	030-21	1-27

25,0 cm, 9 3/4"	030-180-25	425,0 cm, 9 3/4"	030-181-25
-----------------	------------	------------------	------------

GROSS-MAIER

FOERSTER

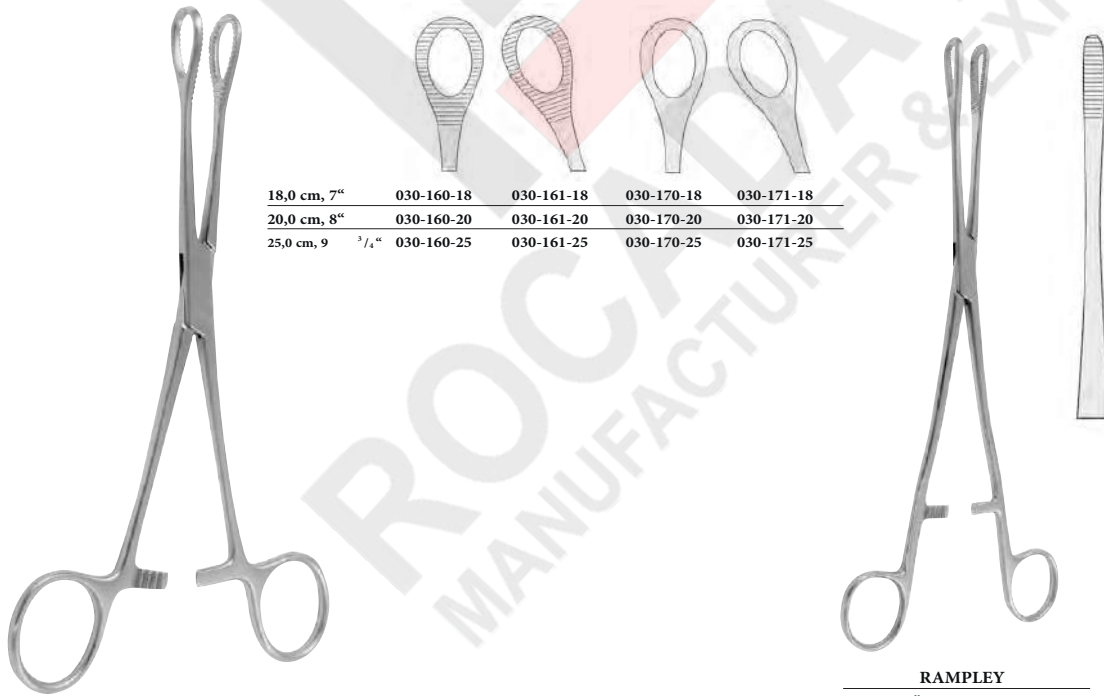

18,0 cm, 7"	030-160-18	030-161-18	030-170-18	030-171-18
20,0 cm, 8"	030-160-20	030-161-20	030-170-20	030-171-20
25,0 cm, 9 3/4"	030-160-25	030-161-25	030-170-25	030-171-25

RAMPLEY	
18,0 cm, 7"	030-190-18
25,0 cm, 9 3/4"	030-190-25

FOERSTER-BALLEGER

RAMPLEY



PRESBYTERIAN

16,5 cm, 6 1/2"	032-012-16
18,0 cm, 7"	032-012-18
20,0 cm, 8"	032-012-20



BERLIN

14,5 cm, 5 3/4"	032-006-14
-----------------	------------



15,0 cm, 6"
032-002-15



18,0 cm, 7"
032-002-18



20,0 cm, 8"
032-002-20



15,0 cm, 6"
032-004-15



18,0 cm, 7"
032-004-18



20,0 cm, 8"
032-004-20

SURGICAL INSTRUMENTS



DIEFFENBACH

3,5 cm, 1 1/2"	026-014-03	026-015-03
5,0 cm, 2"	026-014-05	026-015-05



HESS
026-520-01



HESS
026-520-02



JOHNS-HOPKINS

3,8 cm, 1 1/2"	026-018-04	026-019-04
5,0 cm, 2"	026-018-05	026-019-05
6,3 cm, 2 1/2"	026-018-06	026-019-06
7,6 cm, 3"	026-018-07	026-019-07
9,0 cm, 3 1/2"	026-018-09	026-019-09

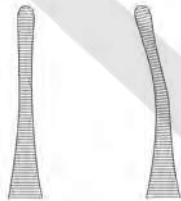

JOHNS-HOPKINS
23,0 cm, 9"
026-295-23



mit atraumatischer Riefung
with non-traumatic serration
con bocas atraumáticas
con presa atraumatica
с атравматичной зазубреност

		L	
17,5 cm, 3"	026-292-07	2,5 cm, 1"	
8,5 cm, 3 1/4"	026-292-08	3,5 cm, 1 3/8"	
10,5 cm, 4 1/8"	026-292-10	5,0 cm, 2"	
12,0 cm, 4 3/4"	026-292-12	6,8 cm, 2 3/4"	

DE BAKEY



mit atraumatischer Riefung
with non-traumatic serration
con bocas atraumáticas
con presa atraumatica
с атравматичной зазубреност

		L	
7,0 cm, 2 3/4"	026-293-07	2,5 cm, 1"	
8,0 cm, 3 1/8"	026-293-08	3,5 cm, 1 3/8"	
10,0 cm, 3 3/4"	026-293-10	5,0 cm, 2"	
11,5 cm, 4 1/2"	026-293-12	6,8 cm, 2 3/4"	

DE BAKEY

SURGICAL INSTRUMENTS



TITANIUM
3,5 cm, 1 3/8"
vena 027-032-35
arteria 027-042-35



TITANIUM
3,5 cm, 1 3/8"
vena 027-033-35
arteria 027-043-35



gerade
straight
recto
retto

TITANIUM
4,0 cm, 1 5/8"
vena 027-032-40
arteria 027-042-40



gebogen
curved
curvo
curvo

TITANIUM
4,0 cm, 1 5/8"
vena 027-033-40
arteria 027-043-40

SURGICAL INSTRUMENTS

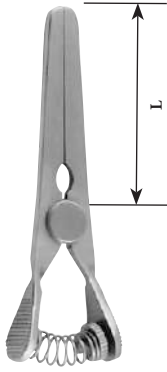

GLOVER

			L		
6,8 cm, 2	$\frac{3}{4}$ "	026-298-07	3,3 cm, 1	$\frac{3}{8}$ "	
9,6 cm, 3	$\frac{3}{4}$ "	026-298-09	5,0 cm, 2"		
11,7 cm, 4	$\frac{3}{4}$ "	026-298-11	6,9 cm, 2	$\frac{3}{4}$ "	

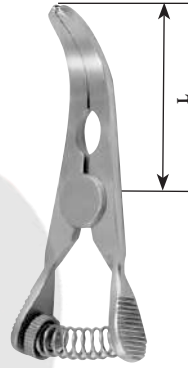

GLOVER

			L		
6,5 cm, 2	$\frac{1}{2}$ "	026-299-06	3,3 cm, 1	$\frac{3}{8}$ "	
9,1 cm, 3	$\frac{1}{2}$ "	026-299-09	5,0 cm, 2"		
11,0 cm, 4	$\frac{3}{8}$ "	026-299-11	6,9 cm, 2	$\frac{3}{4}$ "	



CHAPUT
13,0 cm, 5"
040-370-13



TUFFIER
13,0 cm, 5"
040-372-13



COLLIN
16,0 cm, 6 / $\frac{1}{4}$ " 4
040-376-16



PENNINGTON
 15,5 cm, 6^{cc} / 040-358-15
 20,0 cm, 8^{cc} / 040-358-20



ATRAUMA

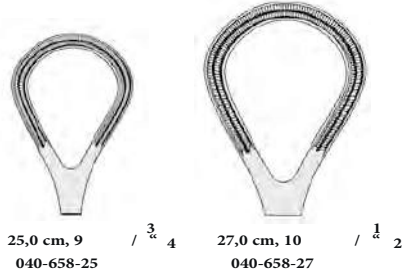

25,0 cm, 9 / $\frac{3}{4}$ 4 / 040-658-25
 27,0 cm, 10 / $\frac{1}{2}$ 2 / 040-658-27



MARTEL
 14,0 cm, 5 / $\frac{1}{2}$ 2 / 040-364-14

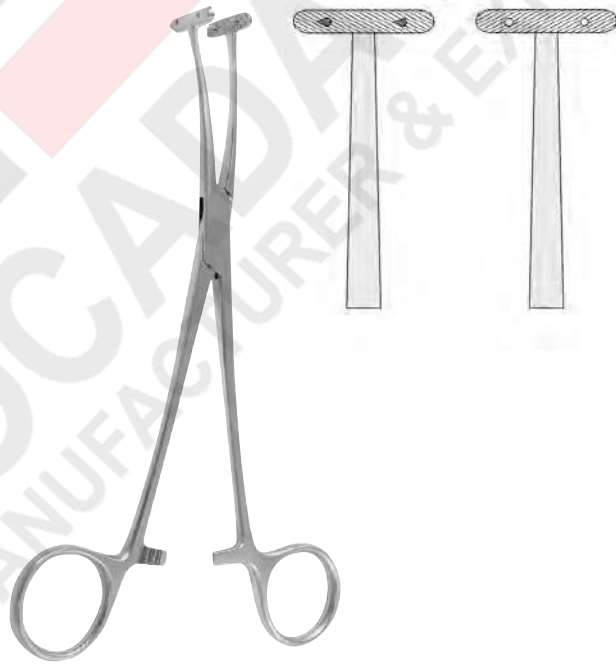

WILLET-MARTEL
 19,0 cm, 7 / $\frac{1}{2}$ 2 / 040-366-19

SURGICAL INSTRUMENTS

SURGICAL INSTRUMENTS



PRATT
15,0 cm, 6"
040-656-15



FERGUSSON

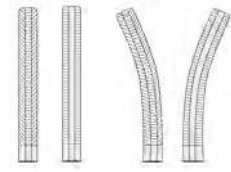

16,0 cm, 6 1/4"	040-650-16	040-651-16
20,0 cm, 8"	040-650-20	040-651-20



CARREL
10,0 cm, 4"
040-010-10



TERRIER
10,0 cm, 4"
040-016-10



KROENLEIN
13,0 cm, 5"
040-369-13

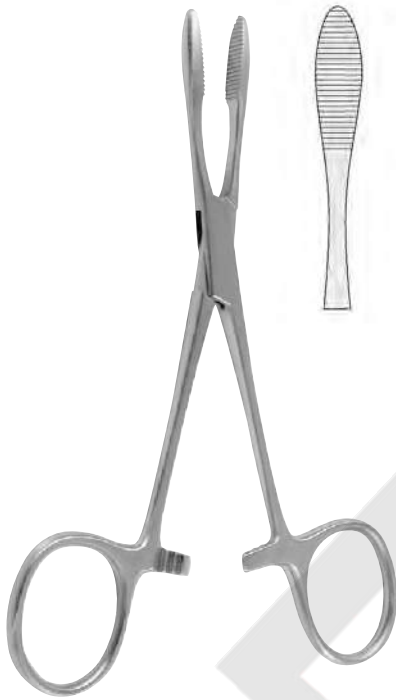

PEAN

14,0 cm, 5	1/2"	040-368-14
16,0 cm, 6	1/4"	040-368-16



BABY-MIXTER

14,0 cm, 5 / 1/2"

040-475-01

040-475-02



SPENCER-WELLS

13,0 cm, 5	040-290-13	040-291-13
15,0 cm, 6"	040-290-15	040-291-15
18,0 cm, 7"	040-290-18	040-291-18
20,0 cm, 8"	040-290-20	040-291-20



HARTMANN

10,0 cm, 4"

040-000-10

040-001-10

SURGICAL INSTRUMENTS

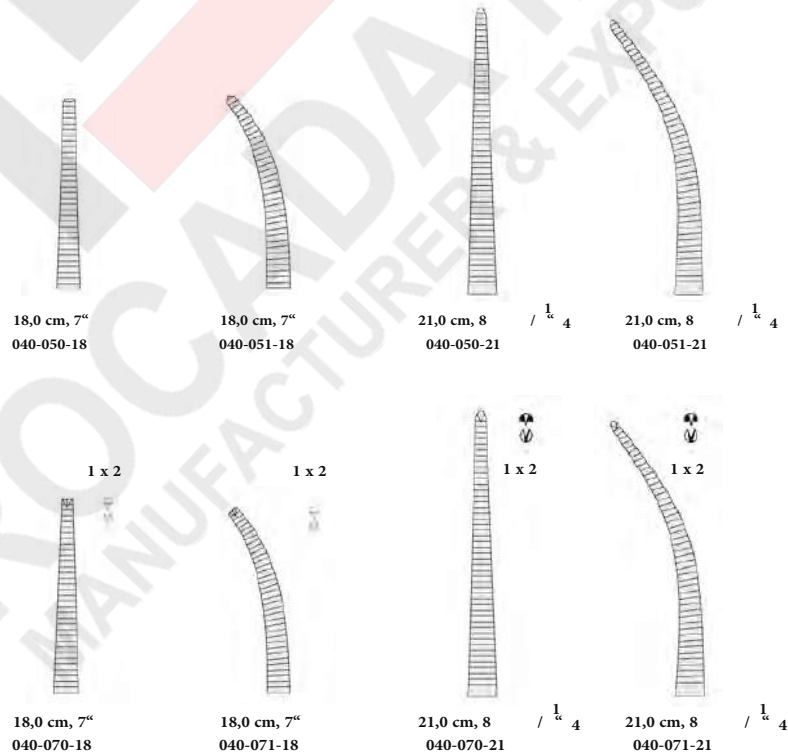
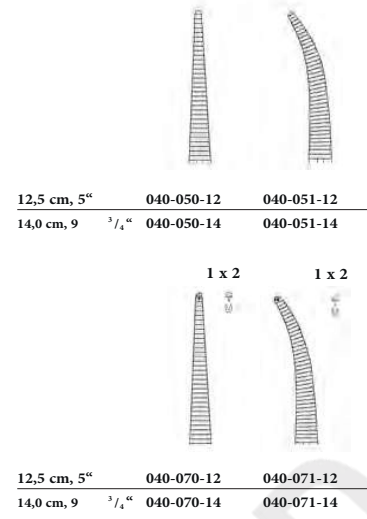
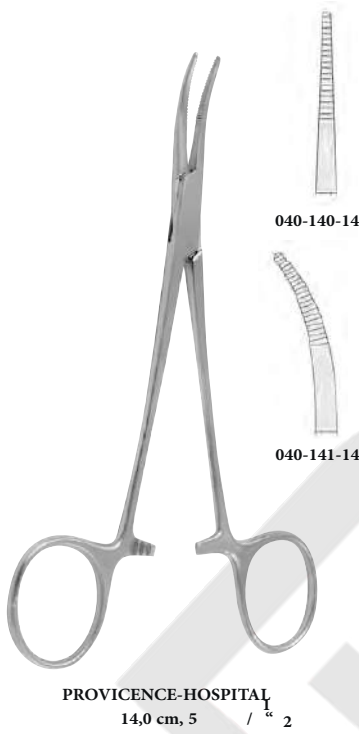



10,0 cm, 4"	040-020-10	040-021-10	040-030-10	040-031-10
12,0 cm, 4 3/4"	040-020-12	040-021-12	040-030-12	040-031-12

MICRO-MOSQUITO



040-150-14

040-151-14

KELLY
14,0 cm, 5 / 1/2



040-152-16

040-153-16

KELLY-RANKIN
16,0 cm, 6 / 1/4

SURGICAL INSTRUMENTS

SURGICAL INSTRUMENTS



LERICHE
15,0 cm, 6"



040-380-15



040-381-15



040-382-15



040-383-15



BABY-OVERHOLT
13,5 cm, 5" / $\frac{1}{4}$ " 4
040-424-14



040-347-14



DANDY
14,0 cm, 5" / $\frac{1}{4}$ " 2



CRILE
14,0 cm, 5" / $\frac{1}{4}$ " 2



040-160-14



040-161-14

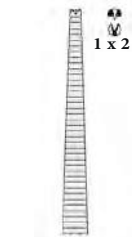

040-170-14



040-171-14

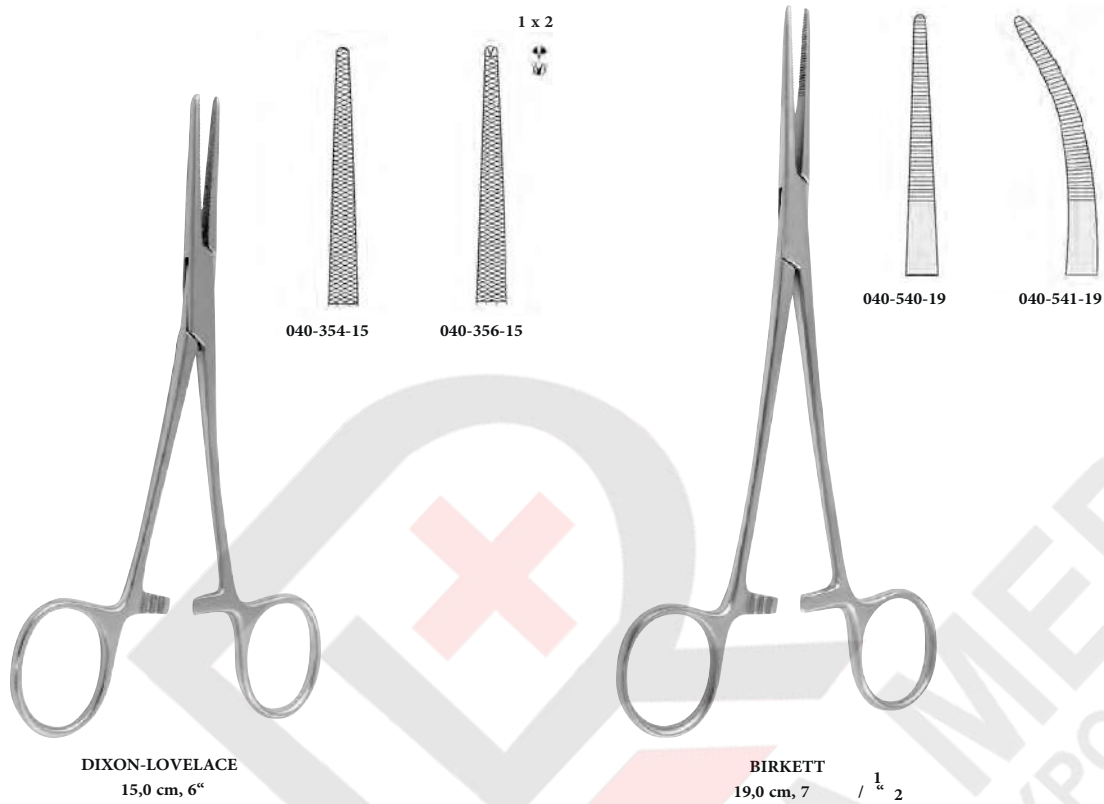

SURGICAL INSTRUMENTS

SURGICAL INSTRUMENTS

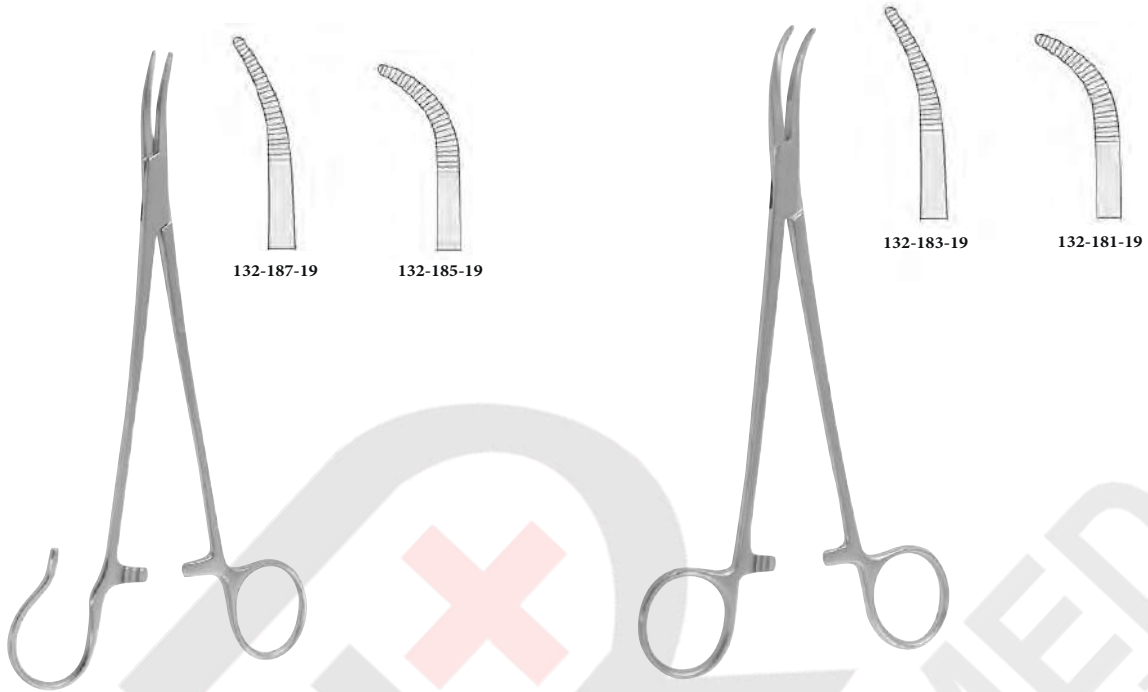

SCHNIDT
19,0 cm, 7 / 1^α 2

SCHNIDT-SAWTELL
19,0 cm, 7 / 1^α 2

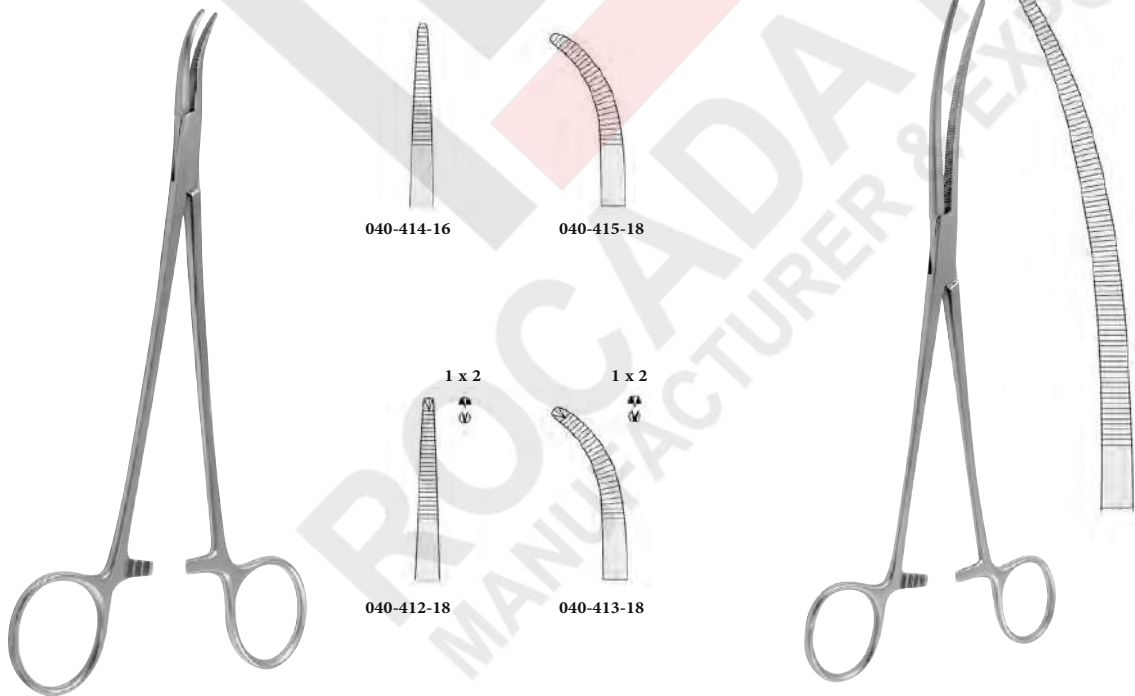

ADSON
18,5 cm, 7 / 1^α 4

CRAFOORD
24,0 cm, 9 / 1^α 2
040-453-24

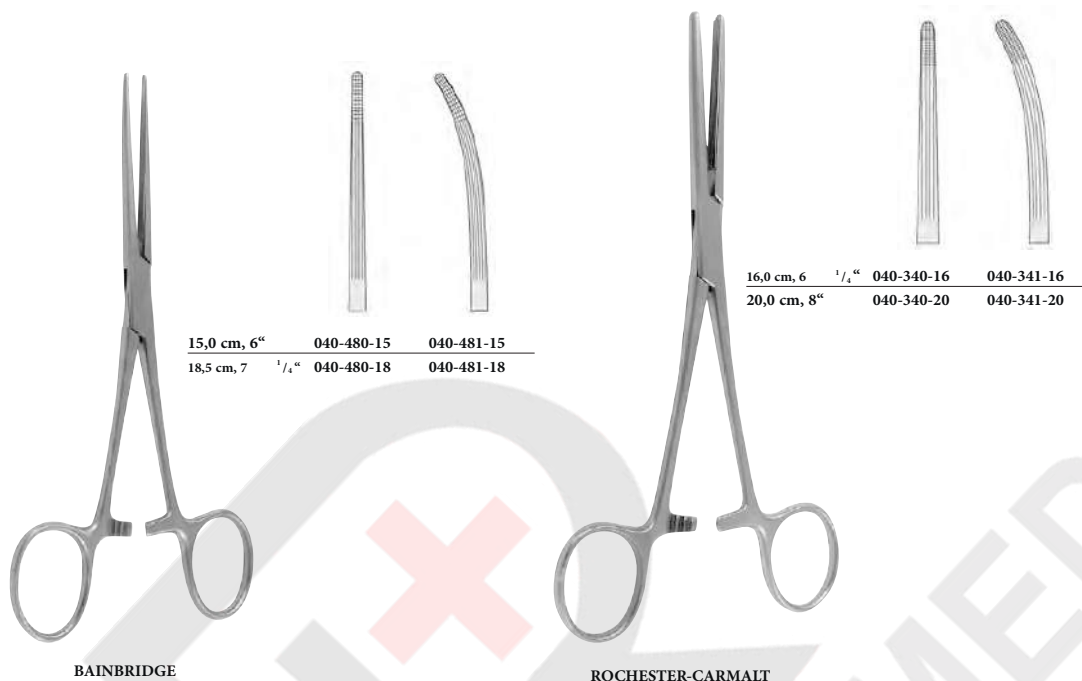

BAINBRIDGE

ROCHESTER-CARMALT



PEAN DELICATE

KOCHER DELICATE

SURGICAL INSTRUMENTS

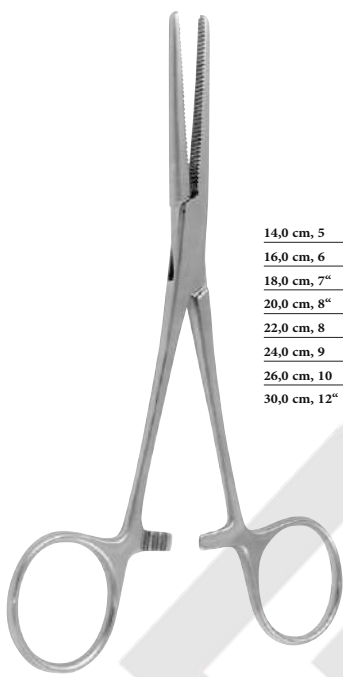

ROCHESTER-PEAN

14,0 cm, 5	1/2"	040-260-14	040-261-14
16,0 cm, 6	1/4"	040-260-16	040-261-16
18,0 cm, 7"		040-260-18	040-261-18
20,0 cm, 8"		040-260-20	040-261-20
22,0 cm, 8	5/8"	040-260-22	040-261-22
24,0 cm, 9	1/2"	040-260-24	040-261-24
26,0 cm, 10	1/4"	040-260-26	040-261-26
30,0 cm, 12"		040-260-30	040-261-30

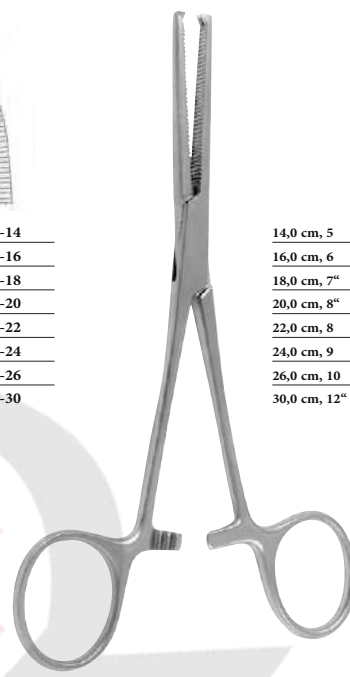
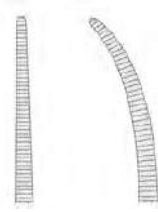

KOCHER-OCHSNER

14,0 cm, 5	1/2"	040-350-14	040-351-14
16,0 cm, 6	1/4"	040-350-16	040-351-16
18,0 cm, 7"		040-350-18	040-351-18
20,0 cm, 8"		040-350-20	040-351-20
22,0 cm, 8	5/8"	040-350-22	040-351-22
24,0 cm, 9	1/2"	040-350-24	040-351-24
26,0 cm, 10	1/4"	040-350-26	040-351-26
30,0 cm, 12"		040-350-30	040-351-30

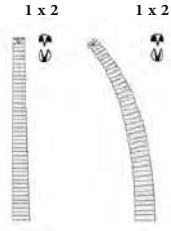

BENGOLEA

20,0 cm, 8"		040-384-20	040-385-20	040-386-20	040-387-20
26,0 cm, 10	1/4"	040-384-26	040-385-26	040-386-26	040-387-26

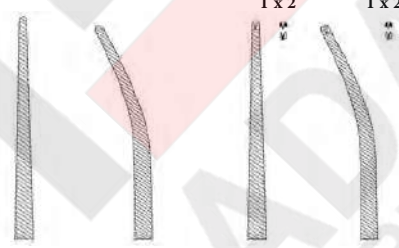



HEISS
20,0 cm, 8"

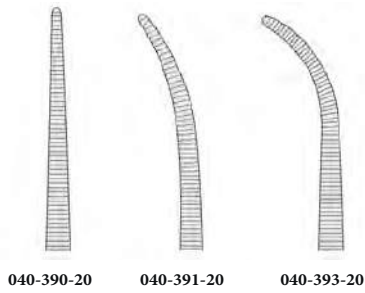

040-390-20 040-391-20 040-393-20



ROBERTS
22,0 cm, 8" / 2.5 8

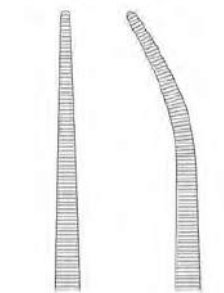

040-448-22 040-449-22



SAROT
24,0 cm, 9" / 1 2

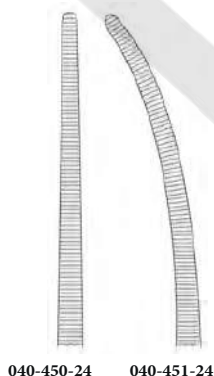

040-450-24 040-451-24



NEGUS
19,0 cm, 7" / 1 2



040-533-01 040-533-02

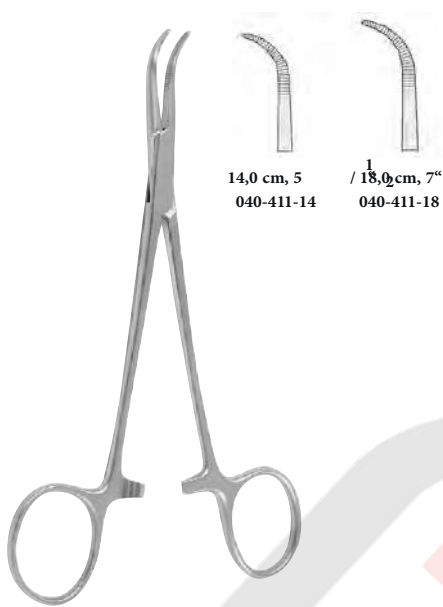

14,0 cm, 5 / 18,0 cm, 7"
040-411-14 040-411-18

BABY-ADSON



14,0 cm, 5 / 1 1/2"
040-409-14

MICRO-ADSON



18,0 cm, 7"
040-475-18

BABY-MIXTER



21,0 cm, 8 / 1 1/4"
040-471-21

OVERHOLT-MIXTER



20,0 cm, 8"
040-497-20

JOHNS HOPKINS



OVERHOLT

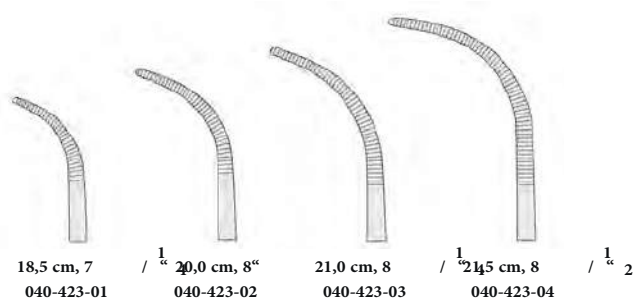

RUMEL
23,0 cm, 9"



SURGICAL INSTRUMENTS

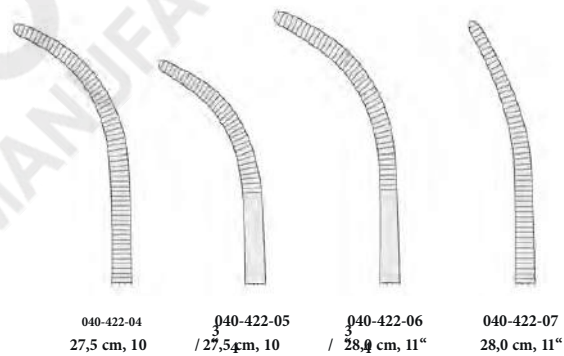
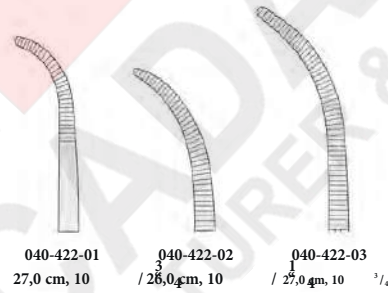
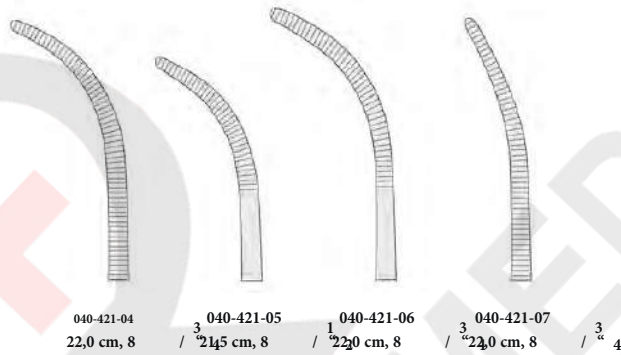
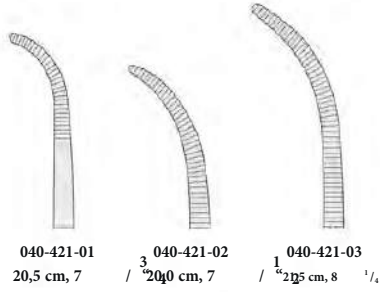

OVERHOLT-GEISSENDOERFER



TOENNIS

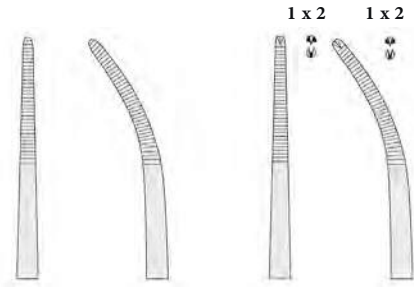

21,0 cm, 8	$\frac{1}{4}$ "	040-442-21	040-443-21	040-444-21	040-445-21
26,0 cm, 10	$\frac{1}{4}$ "	040-442-26	040-443-26	040-444-26	040-445-26



KELLY

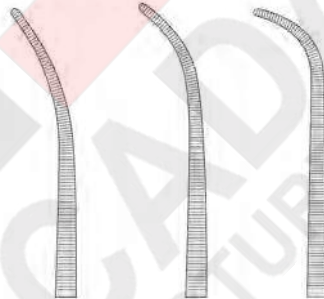

19,0 cm, 7	$\frac{1}{2}$ "	040-463-19	040-465-19	040-467-19
22,0 cm, 8	$\frac{5}{8}$ "	040-463-22	040-465-22	040-467-22
24,0 cm, 9	$\frac{1}{2}$ "	040-463-24	040-465-24	040-467-24



18,0 cm, 7"	040-429-18
22,0 cm, 8 ⁵ / ₈ "	040-429-22
25,0 cm, 9 ³ / ₄ "	040-429-25
28,0 cm, 11"	040-429-28

MINI-GEMINI



14,0 cm, 5 ¹ / ₂ "	040-431-14
16,0 cm, 6 ¹ / ₄ "	040-431-16
18,0 cm, 7"	040-431-18
20,0 cm, 8"	040-431-20
23,0 cm, 9"	040-431-23
25,0 cm, 9 ³ / ₄ "	040-431-25
28,0 cm, 11"	040-431-28

GEMINI

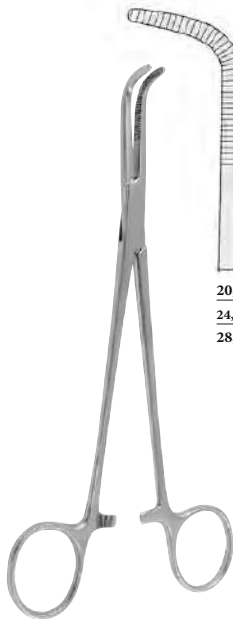

20,0 cm, 8"	040-433-20
24,0 cm, 9 ¹ / ₂ "	040-433-24
28,0 cm, 11"	040-433-28

KANTROWITZ



19,0 cm, 7 ¹ / ₂ "	040-543-19
21,0 cm, 8 ¹ / ₄ "	040-543-21
24,0 cm, 9 ¹ / ₂ "	040-543-24

WIKSTROEM

SURGICAL INSTRUMENTS



MIXTER
 15,5 cm, 6" 040-461-15
 19,0 cm, 7 1/2" 040-461-19



MIXTER-O'SHAUGNESSY
 15,5 cm, 6" 040-477-15
 19,0 cm, 7 1/2" 040-477-19



MIXTER
 22,0 cm, 8 3/4" 040-473-22



MIXTER
 23,0 cm, 9" 040-473-23

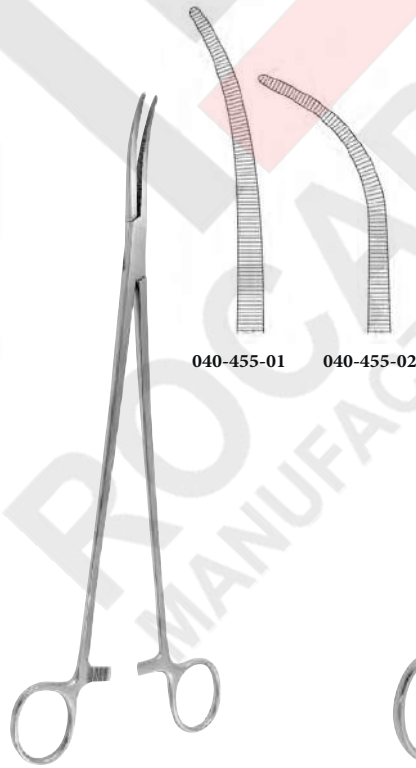

ZENKER

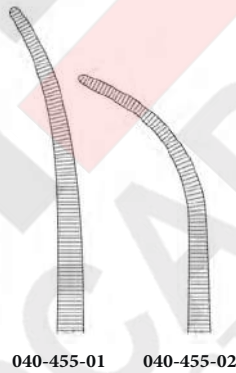

040-455-01 040-455-02



ZENKER

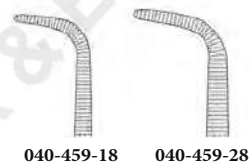

040-459-18 040-459-28

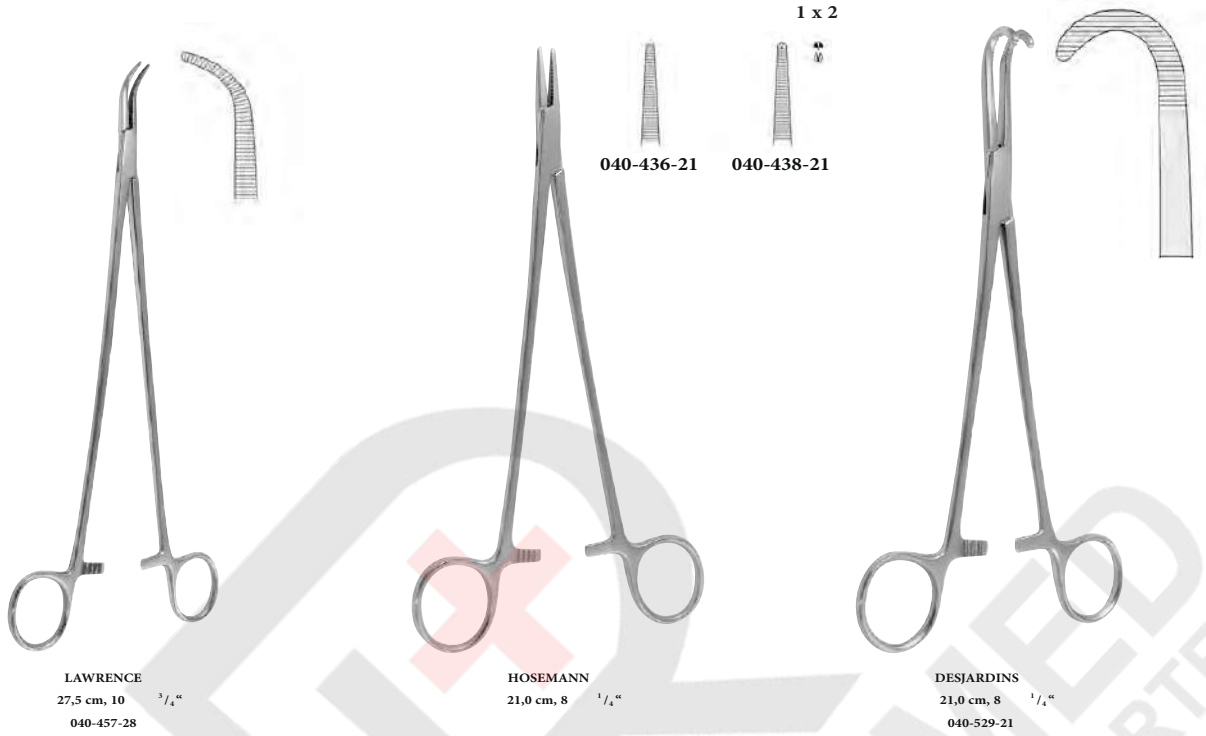

MIXTER

22,0 cm, 8	$\frac{3}{4}$ "	040-479-22
25,0 cm, 9	$\frac{3}{4}$ "	040-479-25
28,0 cm, 11"		040-479-28

LAHEY

19,0 cm, 7	$\frac{1}{2}$ "	040-501-19
23,0 cm, 9"		040-501-23



LOWER
18,0 cm, 7"
040-503-18

SURGICAL INSTRUMENTS

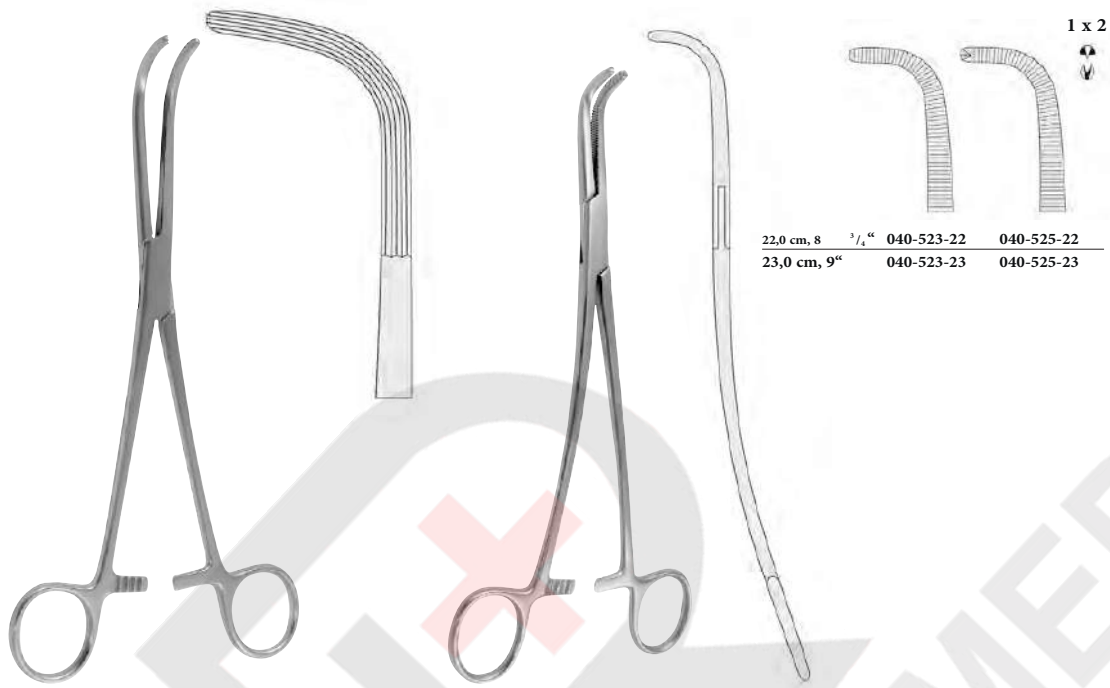

22,0 cm, 8	$\frac{3}{4}$ "	040-523-22	040-525-22
23,0 cm, 9"		040-523-23	040-525-23

MC QUIGG-MIXTER $\frac{3}{4}$
 22,0 cm, 8 / $\frac{3}{4}$
 040-507-22

GRAY

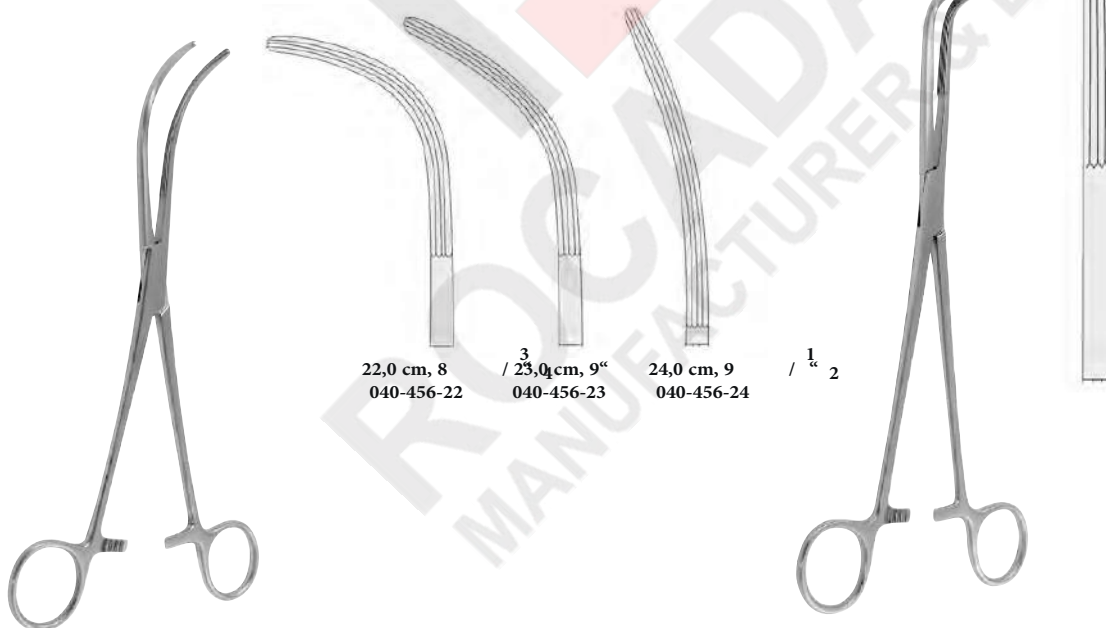

22,0 cm, 8	$\frac{3}{4}$ "	040-456-22	040-456-23	24,0 cm, 9	$\frac{1}{4}$ "	2
------------	-----------------	------------	------------	------------	-----------------	---

CRAFOORD-SELLORS

FINOCCHIETTO $\frac{1}{4}$
 24,0 cm, 9 / $\frac{1}{4}$
 040-505-24

SURGICAL INSTRUMENTS

SURGICAL INSTRUMENTS



GUYON

20,0 cm, 8"	040-509-20
22,0 cm, 8 1/4"	040-509-22
24,0 cm, 9 1/2"	040-509-24



GUYON

23,0 cm, 9"	040-513-23
-------------	------------



GUYON

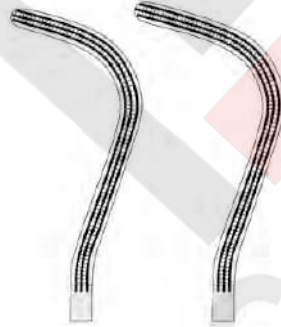

23,0 cm, 9"
158-519-23

24,0 cm, 9 1/2"
158-519-24

1/2"



STILLE
23,0 cm, 9"
040-511-23

Gallenkanal- und Nierenstielklemmen,
 Bronchusklemmen Gall Duct and Kidney
 Pedicle Clamps, Bronchus Forceps Pinzas
 clamps para pedúnculo renal, Pinzas-clamps
 para bronquios Pinze per peduncoli renali,
 Pinze per legature

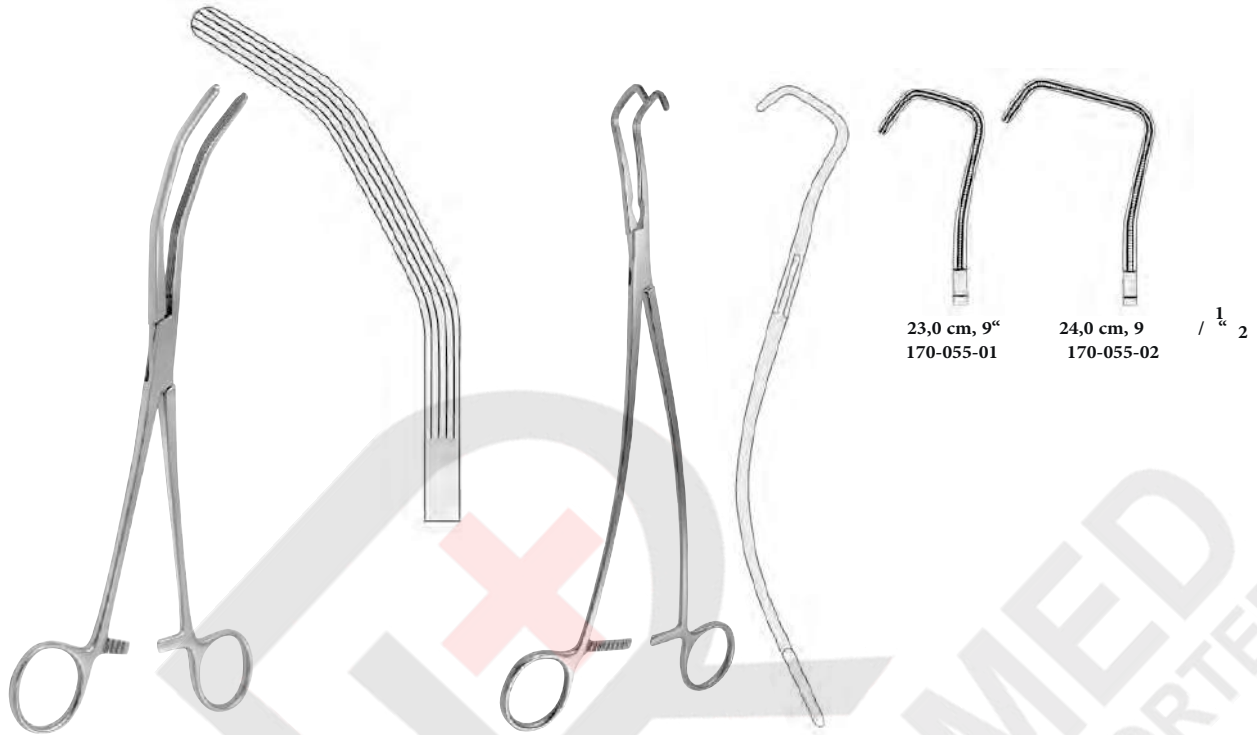

HERRICK
 23,0 cm, 9"
 040-517-23

URO-TANGENTIAL

23,0 cm, 9"
 170-055-01

24,0 cm, 9"
 170-055-02

/ ¹/₂



LOVELACE
 20,0 cm, 8"
 141-004-20



LOVELACE
 20,0 cm, 8"
 141-005-20



PRICE-THOMAS
 22,0 cm, 8" / ³/₄
 141-001-22

SURGICAL INSTRUMENTS

SURGICAL INSTRUMENTS

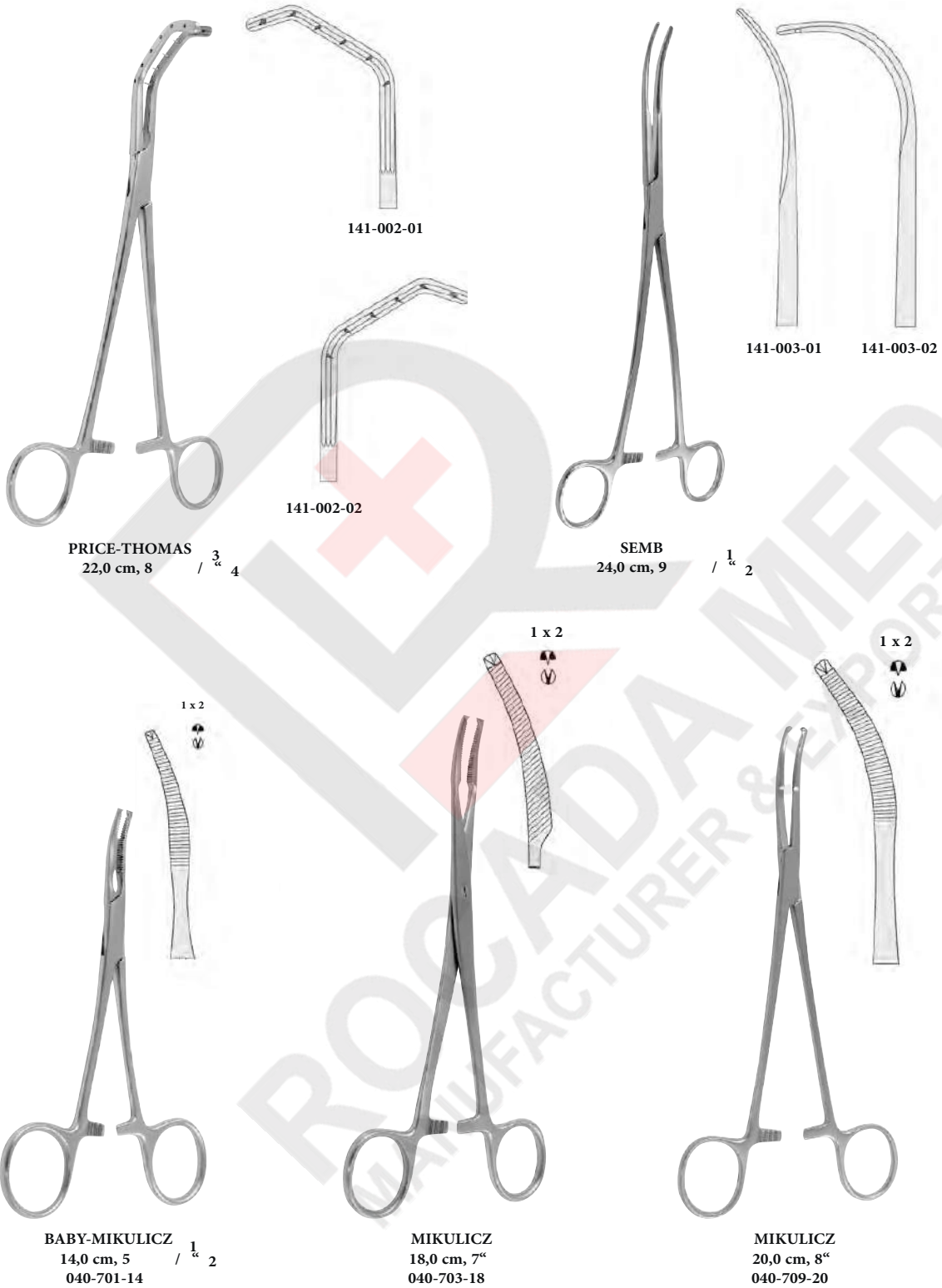

Peritoneumklemmen, Hysterektomieklemmen
Peritoneum Forceps, Hysterectomy Forceps
Pinzas-clamps para peritoneo y para
histerectomía Pinze per peritoneo e per
isterectomia

ROCADA MED
MANUFACTURER & EXPORTER

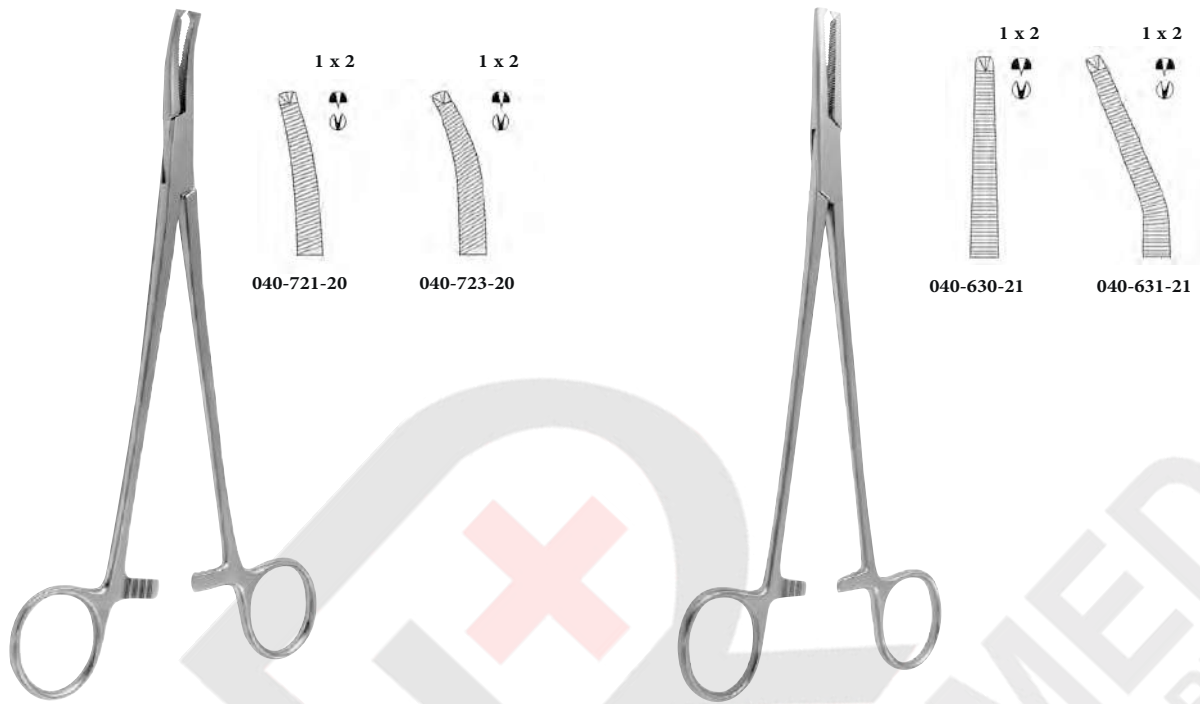

FAURE
20,0 cm, 8"

PHANEUF
21,5 cm, 8" / 1 1/2"

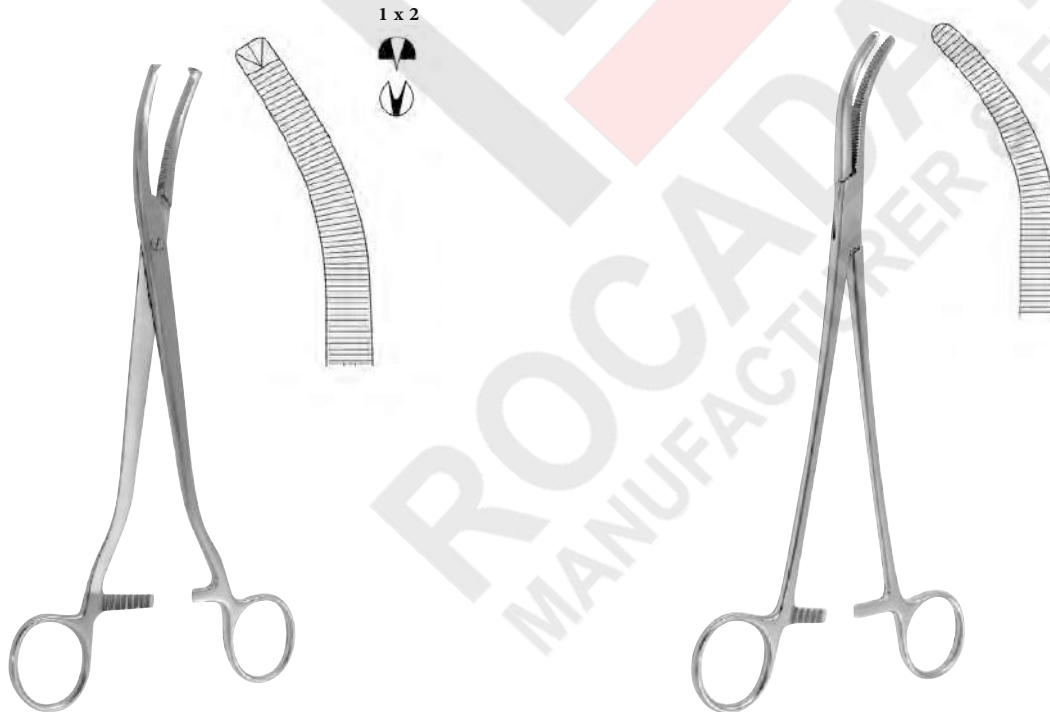

WERTHEIM
24,0 cm, 9" / 1 1/4"

WERTHEIM
25,0 cm, 10"
040-601-24

SURGICAL INSTRUMENTS

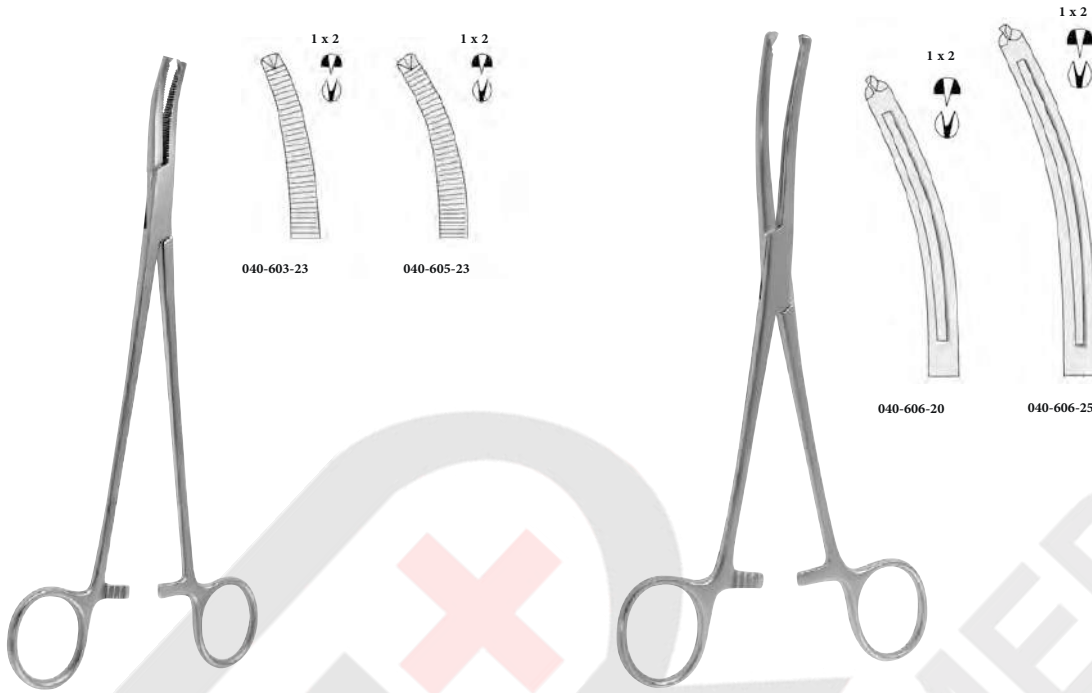

WERTHEIM
23,0 cm, 9"

MAINGOT
21,5 cm, 8 1/2"

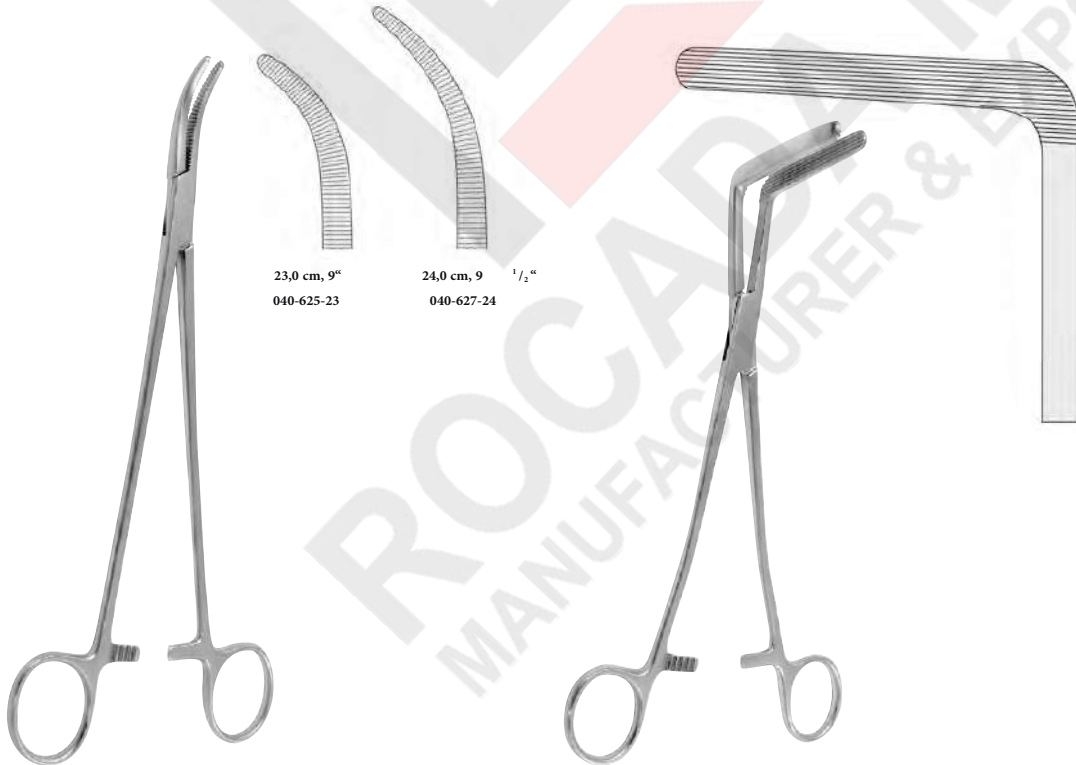

MOYNIHAN

WERTHEIM-CULLEN
21,5 cm, 8 1/2"
040-629-21

SURGICAL INSTRUMENTS

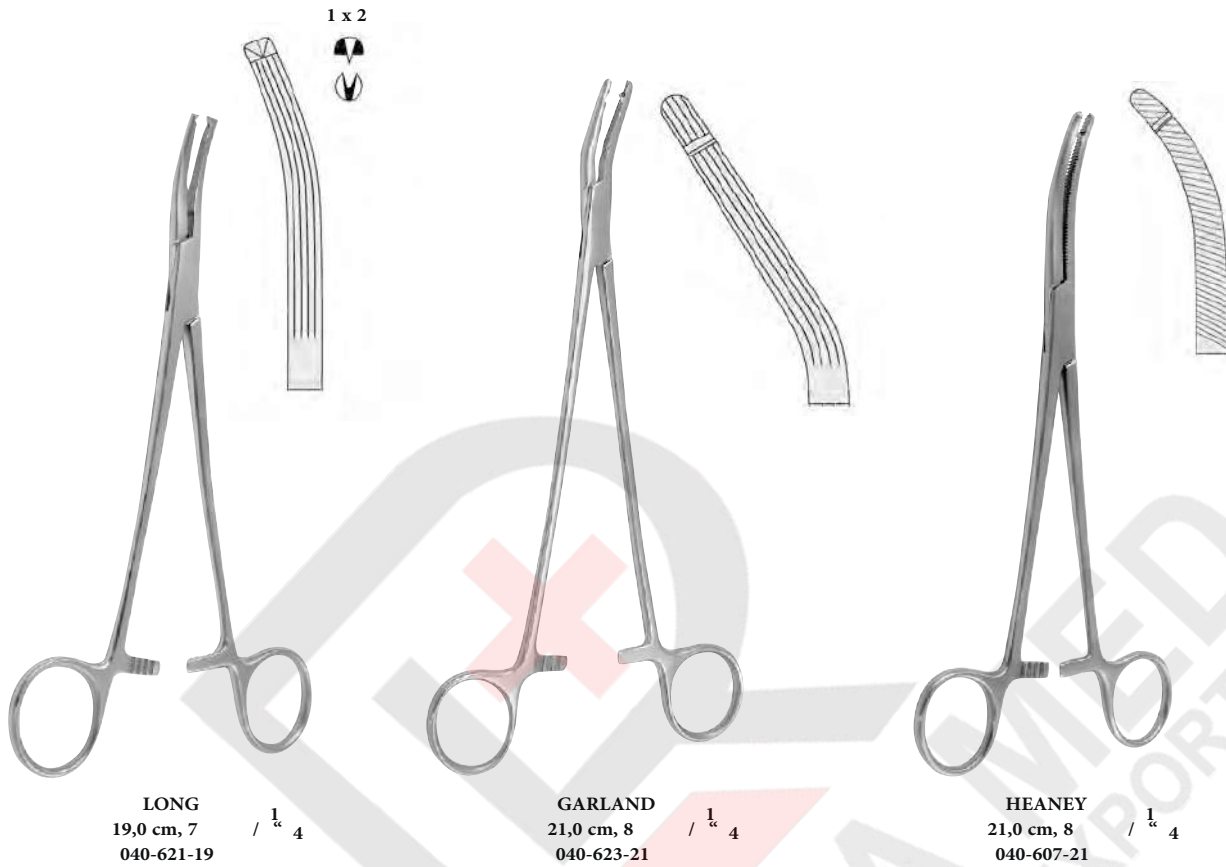

LONG
 19,0 cm, 7 / $\frac{1}{4}$ 4
 040-621-19

GARLAND
 21,0 cm, 8 / $\frac{1}{4}$ 4
 040-623-21

HEANEY
 21,0 cm, 8 / $\frac{1}{4}$ 4
 040-607-21



HEANEY-BALLANTINE
 21,0 cm, 8 / $\frac{1}{4}$ 4

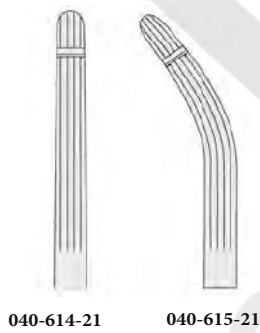

040-614-21

040-615-21

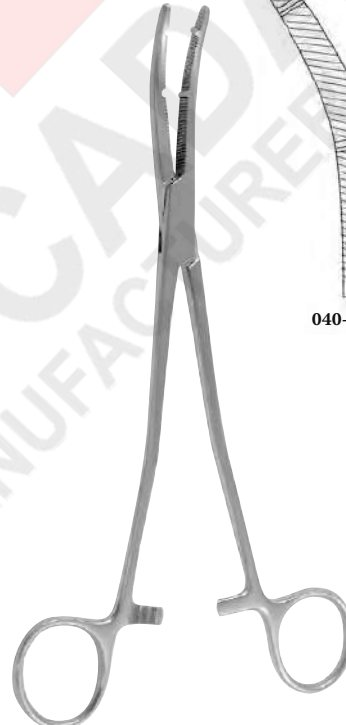

HEANEY-KANTER
 21,0 cm, 8 / $\frac{1}{4}$ 4

SURGICAL INSTRUMENTS



050-010-12
12,0 cm, 4



050-020-12
12,5 cm, 5"



COLLIER
12,5 cm, 5"
050-022-12



WEBSTER
13,0 cm, 5"
050-028-13



HALSEY
13,0 cm, 5"



050-030-13

050-040-13



NEIVERT
13,0 cm, 5"
050-046-13



HEGAR-BAUMGARTNER
14,0 cm, 5" / 2



SURGICAL INSTRUMENTS



050-096-13
13,0 cm, 5"

BROWN



CRILE-MURRAY
15,0 cm, 6"
050-070-15



050-060-15
15,0 cm, 6"

CRILE-WOOD



ADSON
18,0 cm, 7"
050-192-18



METZENBAUM
18,0 cm, 7"
050-190-18



MASS.-GENERAL-HOSPITAL
17,0 cm, 6 ³/₄"
050-072-17

SURGICAL INSTRUMENTS



MAYO-HEGAR

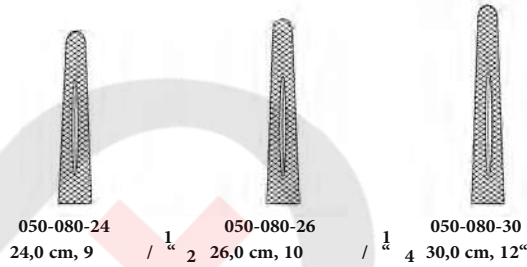
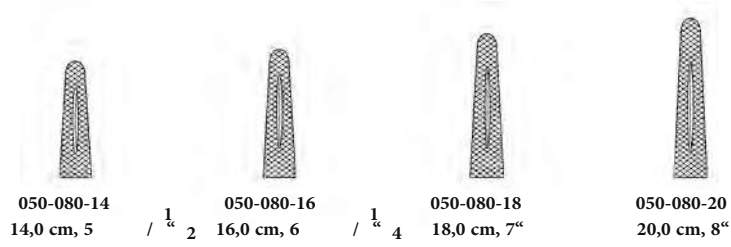

MAYO-HEGAR-DELICATE

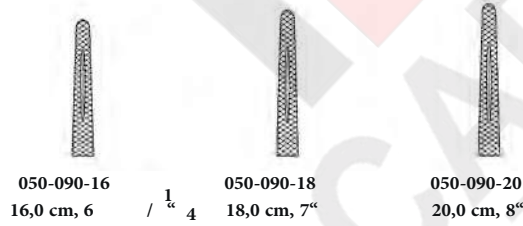

LAWRENCE
15,0 cm, 6"
050-110-15

SURGICAL INSTRUMENTS



HEANEY
21,0 cm, 8 / $\frac{1}{4}$ 4
050-141-21



JAMISON
23,5 cm, 9 / $\frac{1}{4}$ 4
050-148-23



MASSON
27,0 cm, 10 / $\frac{1}{4}$ 2
050-150-27



FINOCCHIETTO
27,0 cm, 10 / $\frac{1}{4}$ 2
050-211-27



WANGENSTEEN
27,0 cm, 10 / $\frac{1}{4}$ 2
050-160-27



JOHNSON
27,0 cm, 10 / $\frac{1}{4}$ 2
050-193-27

SURGICAL INSTRUMENTS

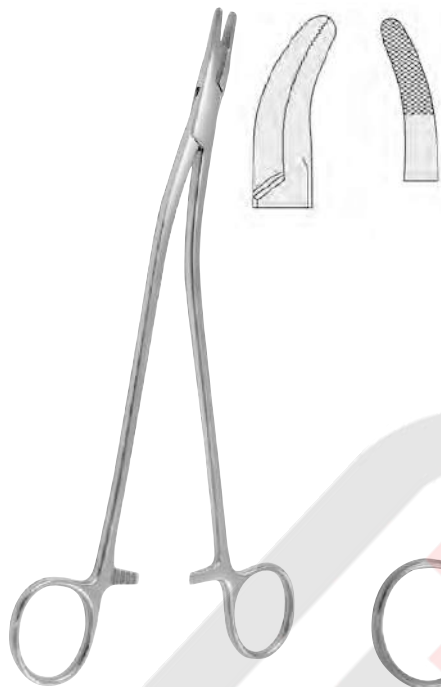

STRATTE
23,0 cm, 9"
050-230-23

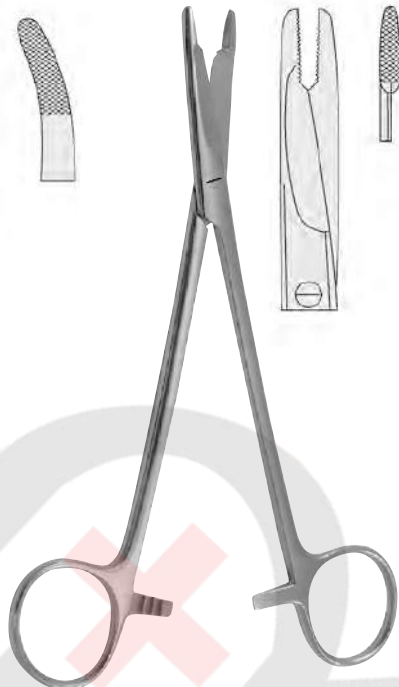

OLSEN-HEGAR
17,0 cm, 6" / 3" 4"

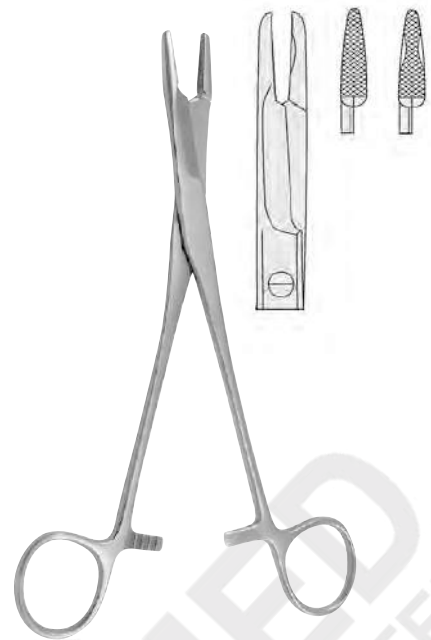

OLSEN-HEGAR
14,0 cm, 5" / 1" 2"



OLSEN-HEGAR

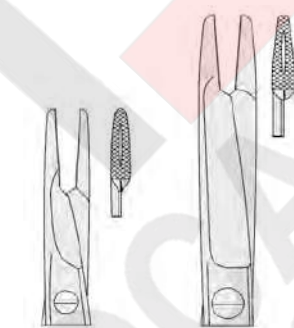

14,0 cm, 5" / 050-310-14
18,0 cm, 7" / 050-310-18



TOENNIS
18,0 cm, 7"
050-362-18

SURGICAL INSTRUMENTS



MATHIEU

050-350-14
14,0 cm, 5

/ $\frac{1}{2}$

050-350-17
17,0 cm, 6

/ $\frac{3}{4}$

050-350-20
20,0 cm, 8"



MATHIEU

050-356-17
17,0 cm, 6

/ $\frac{3}{4}$

050-356-20
20,0 cm, 8"



LICHTENBERG
20,0 cm, 8"
050-366-20



MATHIEU

050-354-14
14,0 cm, 5

/ $\frac{1}{2}$

050-354-17
17,0 cm, 6

/ $\frac{3}{4}$



MATHIEU-KOCHER

050-358-14
14,0 cm, 5

1/2

050-358-17
17,0 cm, 6

3/4

050-358-20
20,0 cm, 8"



BARRAQUER-TROUTMAN
10,0 cm, 4"

050-550-10

050-551-10



BARRAQUER

050-553-10

050-553-13



BARRAQUER
13,5 cm, 5 / 3/8
050-621-13



GOMMEL
14,0 cm, 5 / 1/2
050-601-14

SURGICAL INSTRUMENTS

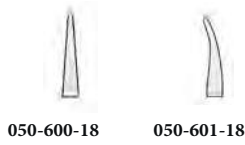

050-600-18 050-601-18

ohne Sperre
 without ratchet
 sin cremallera
 senza cremagliera

18,5 cm, 7 / $\frac{1}{4}$ 4

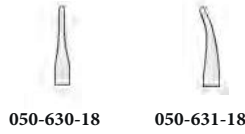

050-630-18 050-631-18

mit Sperre
 with ratchet
 con cremallera
 con cremagliera

18,5 cm, 7 / $\frac{1}{4}$ 4

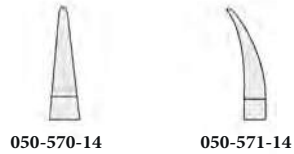

050-570-14 050-571-14

mit Sperre
 with ratchet
 con cremallera
 con cremagliera

CASTROVIEJO
 14,5 cm, 5 / $\frac{3}{4}$ 4



050-570-18 050-571-18

mit Sperre
 with ratchet
 con cremallera
 con cremagliera

CASTROVIEJO
 18,0 cm, 7"

SURGICAL INSTRUMENTS

gerade, ohne Sperre
straight, without ratchet
recta, sin cremallera
retta, senza cremagliera

0,4 mm



14,0 cm, 5 / 1/2
050-650-14

gebogen, ohne Sperre
curved, without ratchet
curva, sin cremallera
curva, senza cremagliera

0,4 mm



14,0 cm, 5 / 1/2
050-651-14

gebogen, mit Sperre
curved, with ratchet
curva, con cremallera
curva, con cremagliera

0,4 mm



14,0 cm, 5 1/2
050-653-14

gebogen, ohne Sperre
curved, without ratchet
curva, sin cremallera
curva, senza cremagliera

0,5 mm



14,0 cm, 5 / 1/2
050-661-14

gebogen, mit Sperre
curved, with ratchet
curva, con cremallera
curva, con cremagliera

0,5 mm



14,0 cm, 5 / 1/2
050-663-14

gebogen, ohne Sperre
curved, without ratchet
curva, sin cremallera
curva, senza cremagliera

0,4 mm



13,0 cm, 5"
050-671-13



KALT
 13,5 cm, 5 / $\frac{3}{8}$ 8
 051-428-14



16,0 cm, 5	$\frac{3}{8}$ "	051-250-16
18,0 cm, 7"		051-250-18
20,0 cm, 8"		051-250-20
23,0 cm, 9"		051-250-23
26,0 cm, 10	$\frac{1}{4}$ "	051-250-26

DIETRICH



WEBSTER
 13,0 cm, 5"
 051-028-13

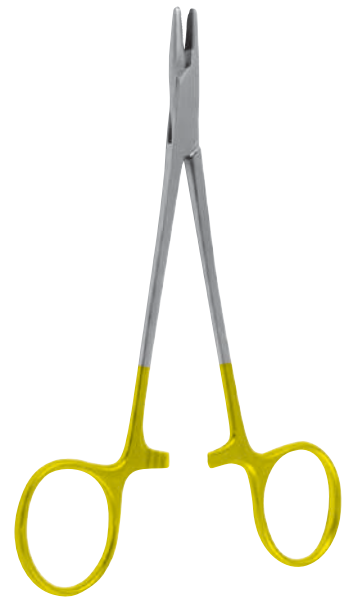

DERF
 12,0 cm, 4 / $\frac{3}{4}$ 4
 051-010-12



051-048-12	12,5 cm, 5"	
051-048-14	14,0 cm, 5	$\frac{1}{4}$ 2

HEGAR-BAUMGARTNER

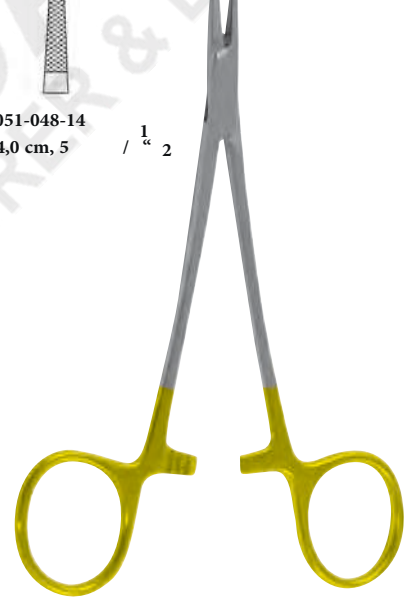

WEBSTER
 13,0 cm, 5"
 051-029-13

SURGICAL INSTRUMENTS



HALSEY
13,0 cm, 5"

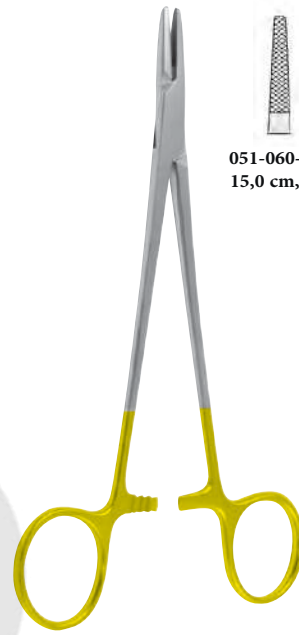
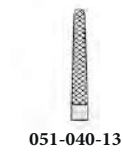
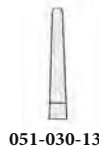

CRILE-WOOD



SAROT

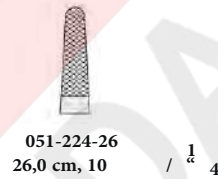

SURGICAL INSTRUMENTS



MAYO-HEGAR

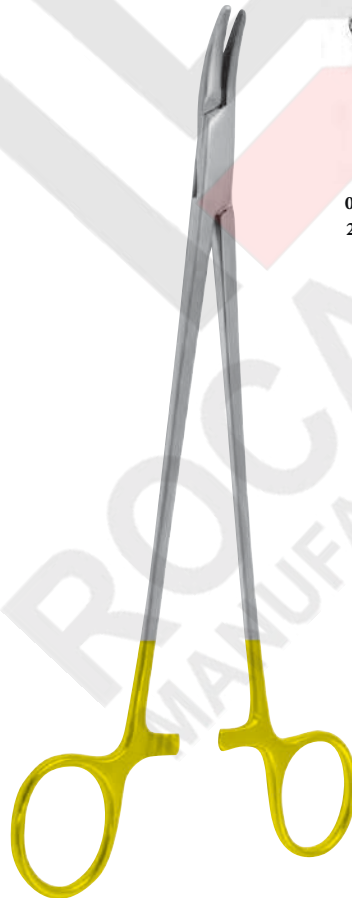
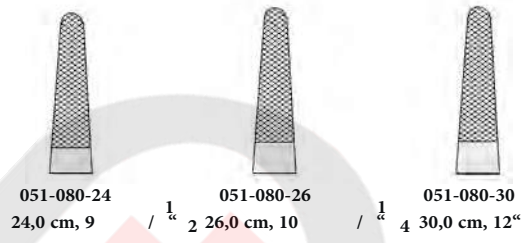
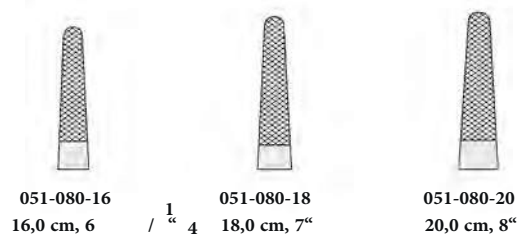

MAYO-HEGAR (HEANEY)

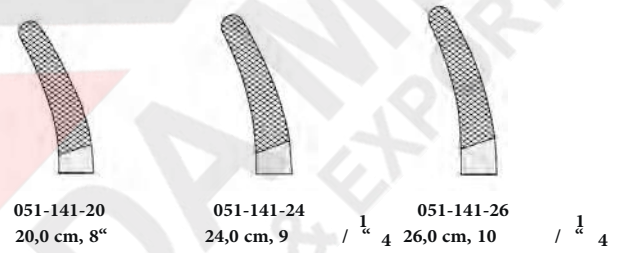

SURGICAL INSTRUMENTS



DE BAKEY



051-114-18
18,0 cm, 7"



051-114-20
20,0 cm, 8"



051-114-23
23,0 cm, 9"



051-114-26
26,0 cm, 10"



1/4 051-114-31
21,0 cm, 12"



1/4 051-114-37
43,0 cm, 14"



RYDER-VASCULAR



051-132-13
13,0 cm, 5"



051-132-15
15,0 cm, 6"



051-132-18
18,0 cm, 7"



051-132-20
20,0 cm, 8"



051-132-23
23,0 cm, 9"



051-132-26
26,0 cm, 10" / 1/4 4

Nadelhalter mit Hartmetalleinlagen
Needle Holders with tungsten carbide inserts
Porta-agujas con bocas de carburo tungsteno
Portaghi con morsi in carburo di tungsteno

ROCADA MED
MANUFACTURER & EXPORTER



RYDER



051-134-13
13,0 cm, 5"

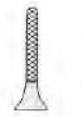

051-134-15
15,0 cm, 6"



051-134-18
18,0 cm, 7"



051-134-20
20,0 cm, 8"



051-134-23
23,0 cm, 9"



051-134-26
26,0 cm, 10" / $\frac{1}{4}$ 4



SCHWEDISCHES MODELL



051-136-15
15,0 cm, 6"



051-136-17
17,0 cm, 6" / $\frac{3}{4}$ 4



051-136-20
20,0 cm, 8"

SURGICAL INSTRUMENTS

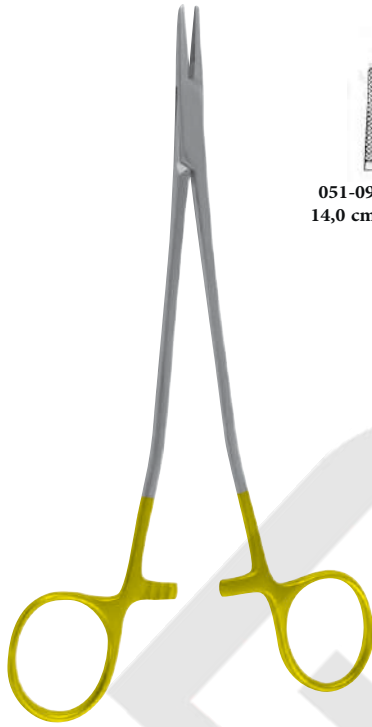

MAYO-HEGAR (HEANEY)

051-090-14
14,0 cm, 5

/ $\frac{1}{2}$

051-090-18
18,0 cm, 7"

051-090-20
20,0 cm, 8"

051-090-23
23,0 cm, 9"



FINOCCHIETTO
27,0 cm, 10 / $\frac{1}{2}$ 2
051-211-27



MASSON
27,0 cm, 10 / $\frac{1}{2}$ 2
051-150-27



WANGENSTEEN
27,0 cm, 10 / $\frac{1}{2}$ 2
051-160-27



SURGICAL INSTRUMENTS

Nadelhalter mit Hartmetalleinlagen
 Needle Holders with tungsten carbide inserts
 Porta-agujas con bocas de carburo tungsteno
 Portaghi con morsi in carburo di tungsteno

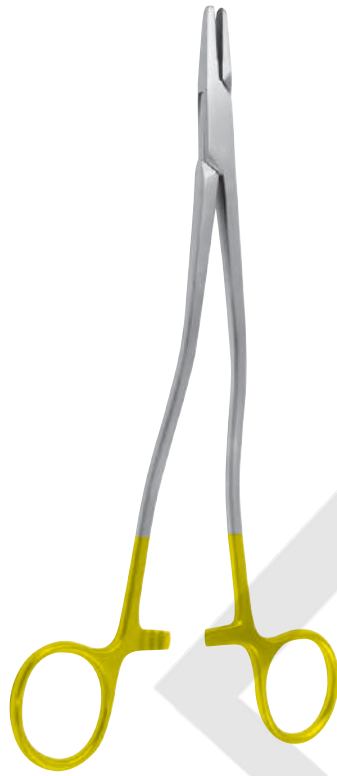

BOZEMANN



051-185-20
 20,0 cm, 8"



051-185-24
 24,0 cm, 9"



051-185-26
 26,0 cm, 10"



HEGAR



051-084-20
 20,0 cm, 8"



051-084-24
 24,0 cm, 9"



BARRY STERNAL



051-240-15
 15,0 cm, 6"



051-242-20
 20,0 cm, 8"

SURGICAL INSTRUMENTS



STRATTE



051-230-22
22,0 cm, 8



5 / 8 051-230-23
23,0 cm, 9⁶



GILLIES
16,0 cm, 6
051-330-16

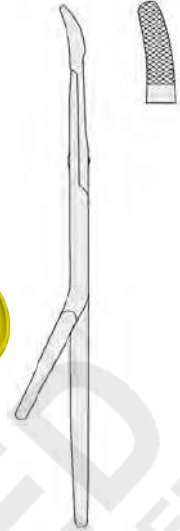

1 / 4



OLSEN-HEGAR



051-310-14
14,0 cm, 5



1 / 4 051-310-17
17,0 cm, 6



3 / 4 051-310-18
18,0 cm, 7⁶



TOENNIS
18,0 cm, 7⁶
051-362-18

Nadelhalter mit Hartmetalleinlagen
Needle Holders with tungsten carbide inserts
Porta-agujas con bocas de carburo tungsteno
Portaghi con morsi in carburo di tungsteno



MATHIEU-KOCHER

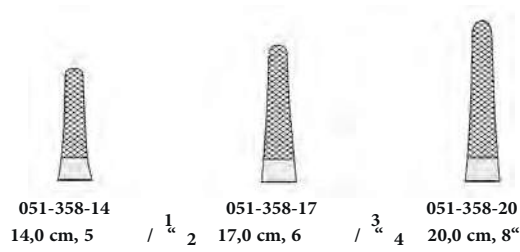

MATHIEU

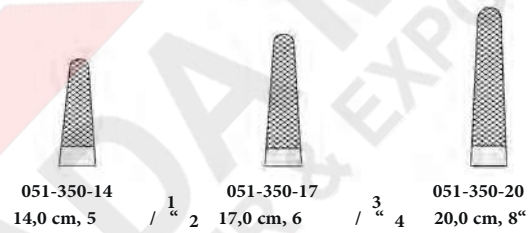

SURGICAL INSTRUMENTS

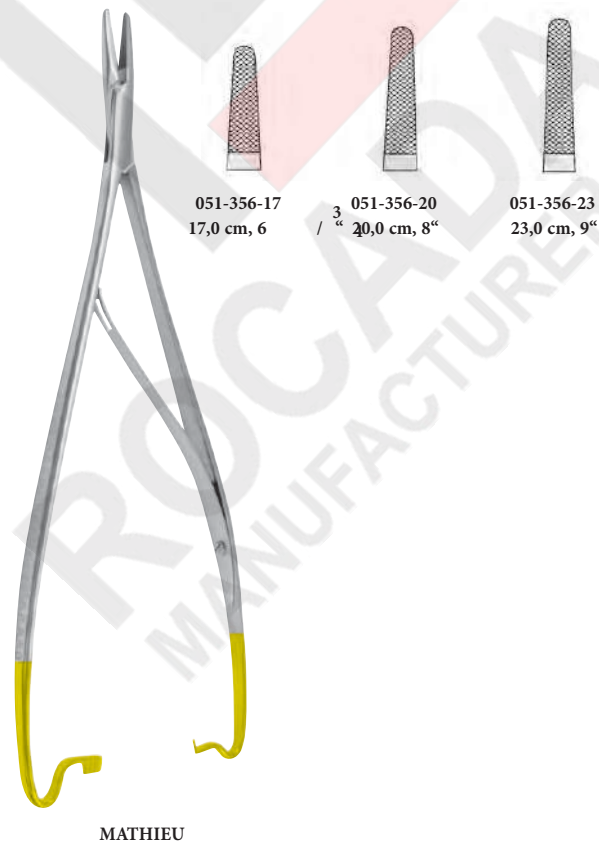
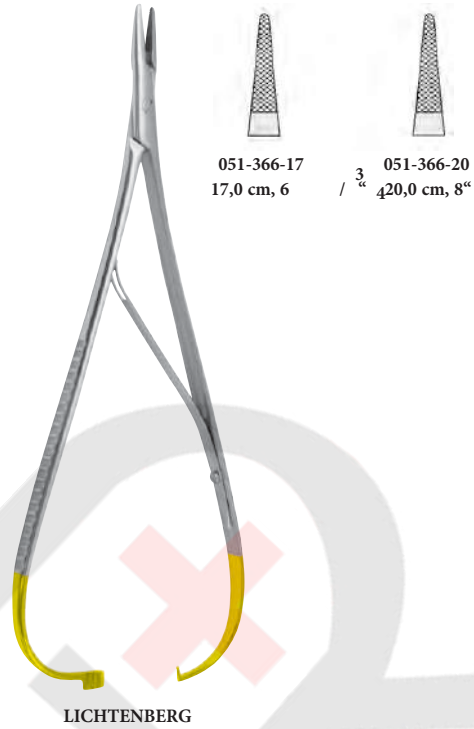

Nadelhalter mit Hartmetalleinlagen
Needle Holders with tungsten carbide inserts
Porta-agujas con bocas de carburo tungsteno
Portaghi con morsi in carburo di tungsteno

ROCADA MED
MANUFACTURER & EXPORTER

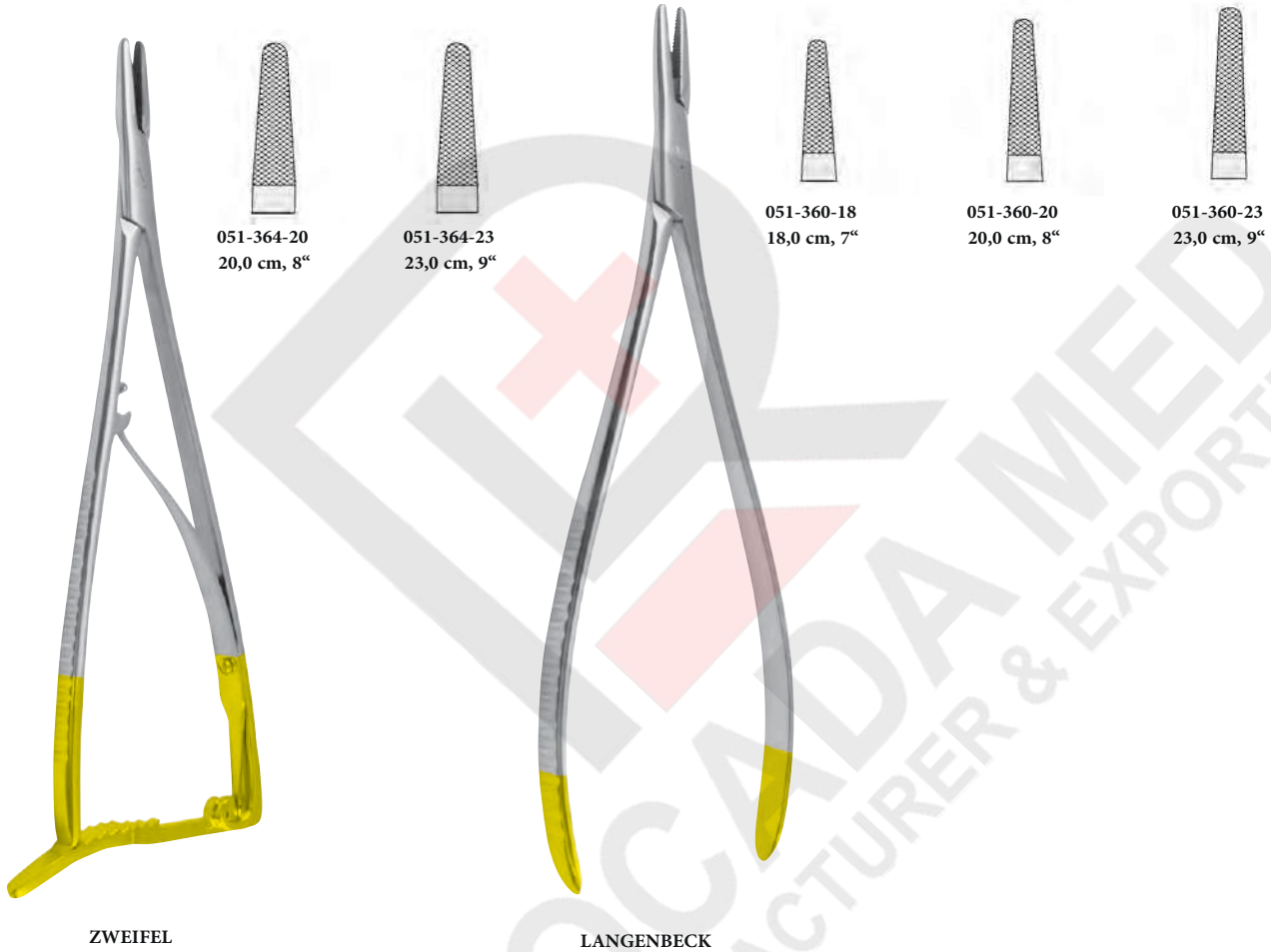

SURGICAL INSTRUMENTS

SURGICAL INSTRUMENTS

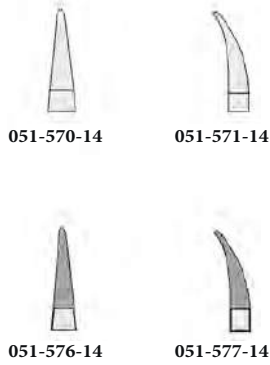

mit Sperre
with ratchet
con cremallera
con cremagliera

CASTROVIEJO
14,5 cm, 5 / $\frac{3}{4}$

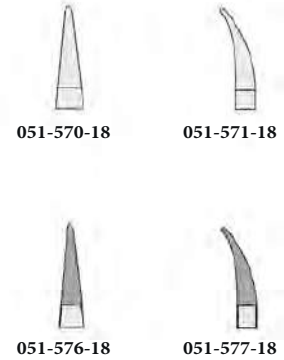

mit Sperre
with ratchet
con cremallera
con cremagliera

CASTROVIEJO
18,0 cm, 7"

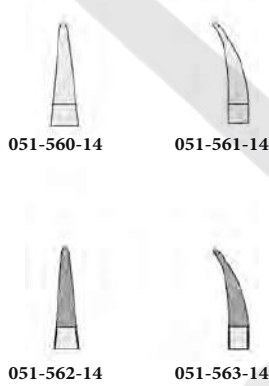

mit Sperre
with ratchet
con cremallera
con cremagliera

BARRAQUER
14,5 cm, 5 / $\frac{3}{4}$



HEPP SCHEIDEL
18,0 cm, 7"
051-390-18



REVERDIN
 14,0 cm, 5 / $\frac{1}{8}$ 2



056-211-01



056-211-02



056-211-03



056-211-04



REVERDIN



19,5 cm, 7 $\frac{3}{4}$ " 056-221-01



056-221-02



056-221-03



056-221-04

22,5 cm, 8 $\frac{3}{4}$ " 056-223-01

056-223-02

056-223-03

056-223-04

SURGICAL INSTRUMENTS

SURGICAL INSTRUMENTS

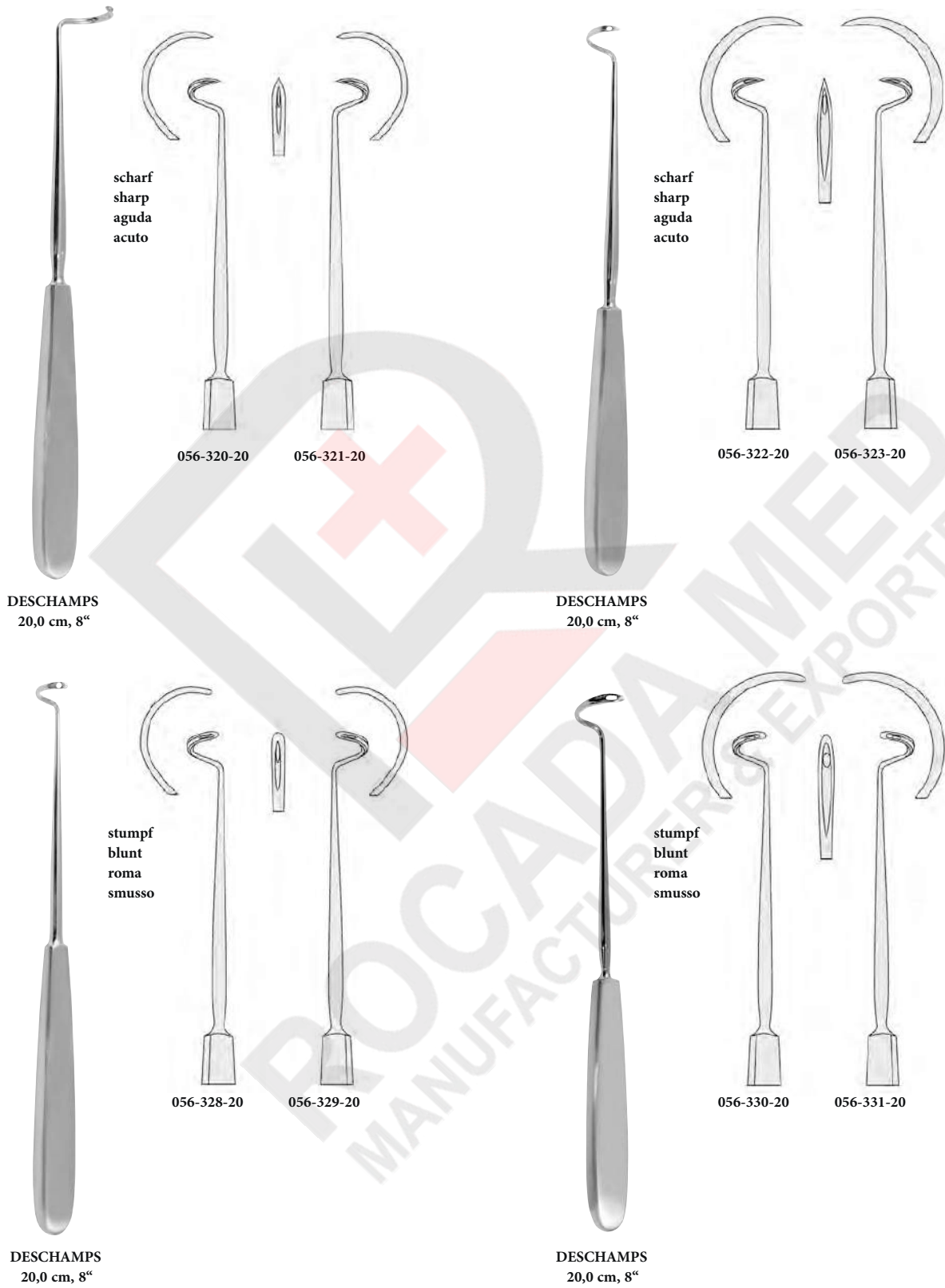

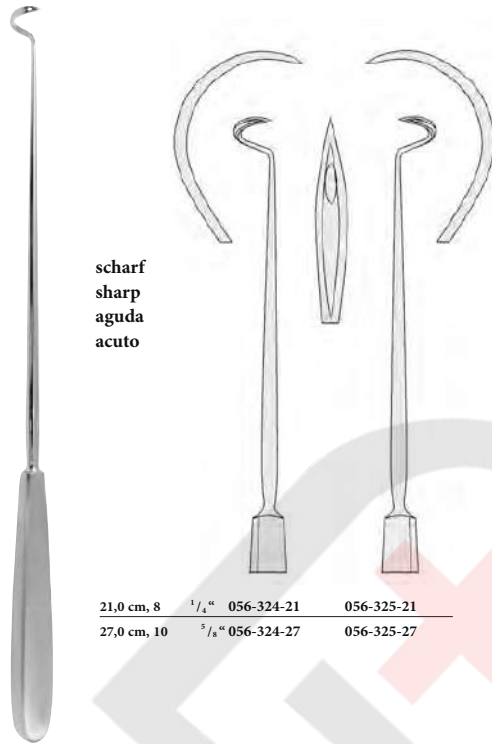

scharf
 sharp
 aguda
 acuto

21,0 cm, 8	$\frac{1}{4}$ "	056-324-21	056-325-21
27,0 cm, 10	$\frac{5}{8}$ "	056-324-27	056-325-27

DESCHAMPS

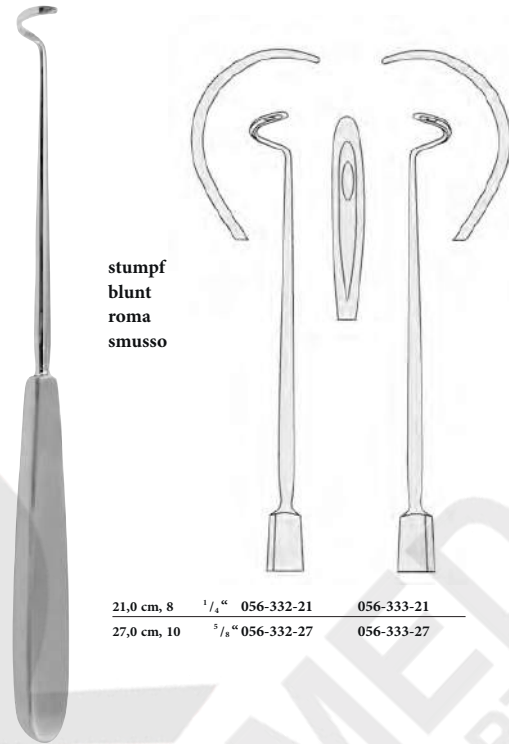

stumpf
 blunt
 roma
 smusso

21,0 cm, 8	$\frac{1}{4}$ "	056-332-21	056-333-21
27,0 cm, 10	$\frac{5}{8}$ "	056-332-27	056-333-27

DESCHAMPS



biegsam
 malleable
 malleable
 malleabile

20,0 cm, 8"
 056-450-20

COOPER
 19,0 cm, 7 / $\frac{1}{2}$ "
 056-451-19

COOPER
 20,0 cm, 8"
 056-451-20

SYME
 15,0 cm, 6"
 056-453-15

SURGICAL INSTRUMENTS



056-452-01

1 / 2

19,0 cm, 7

KOCHER

1 / 2

19,0 cm, 7



056-452-02

056-452-03



BRUNNER
25,0 cm, 9
056-455-25

3 / 4



056-454-01

056-454-02

BRUNNER
30,0 cm, 11

3 / 4



SCHMIEDEN
21,0 cm, 8
056-458-21

1 / 4

SURGICAL INSTRUMENTS



YOUNG-HRYNTSCHAK
24,0 cm, 9 / ³/₄ 2
056-460-24



056-460-01



056-460-02



056-460-03



DE LA ROZA
12,0 cm, 4 / ³/₄ 4
056-467-01



DE LA ROZA
12,0 cm, 4 / ³/₄ 4
056-467-02



JAKOBI
14,0 cm, 5 / ¹/₂ 2
056-469-14



HESSEBERG
15,0 cm, 6"
056-468-15



KRONECKER
15,0 cm, 6"
056-470-01

SURGICAL INSTRUMENTS



KRONECKER
15,0 cm, 6"
056-470-02



TRELAT
23,0 cm, 9"
056-472-23



CLAUS
23,0 cm, 9"
056-473-23



HURD
21,0 cm, 8
056-474-01



HURD
21,0 cm, 8 / 1/4 4
056-474-02



NAGER
24,0 cm, 9 / 1/4 2
056-477-24



CLAUS-EICKEN
23,0 cm, 9"
056-481-23

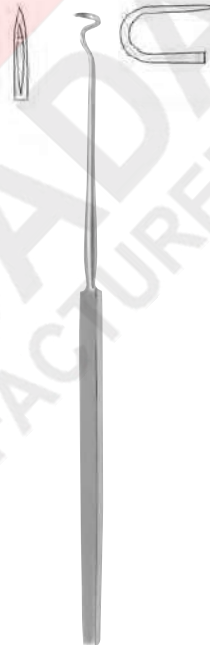

FALK
24,0 cm, 9 / 1/4 2
056-480-01



FALK
24,0 cm, 9 / 1/4 2
056-480-02

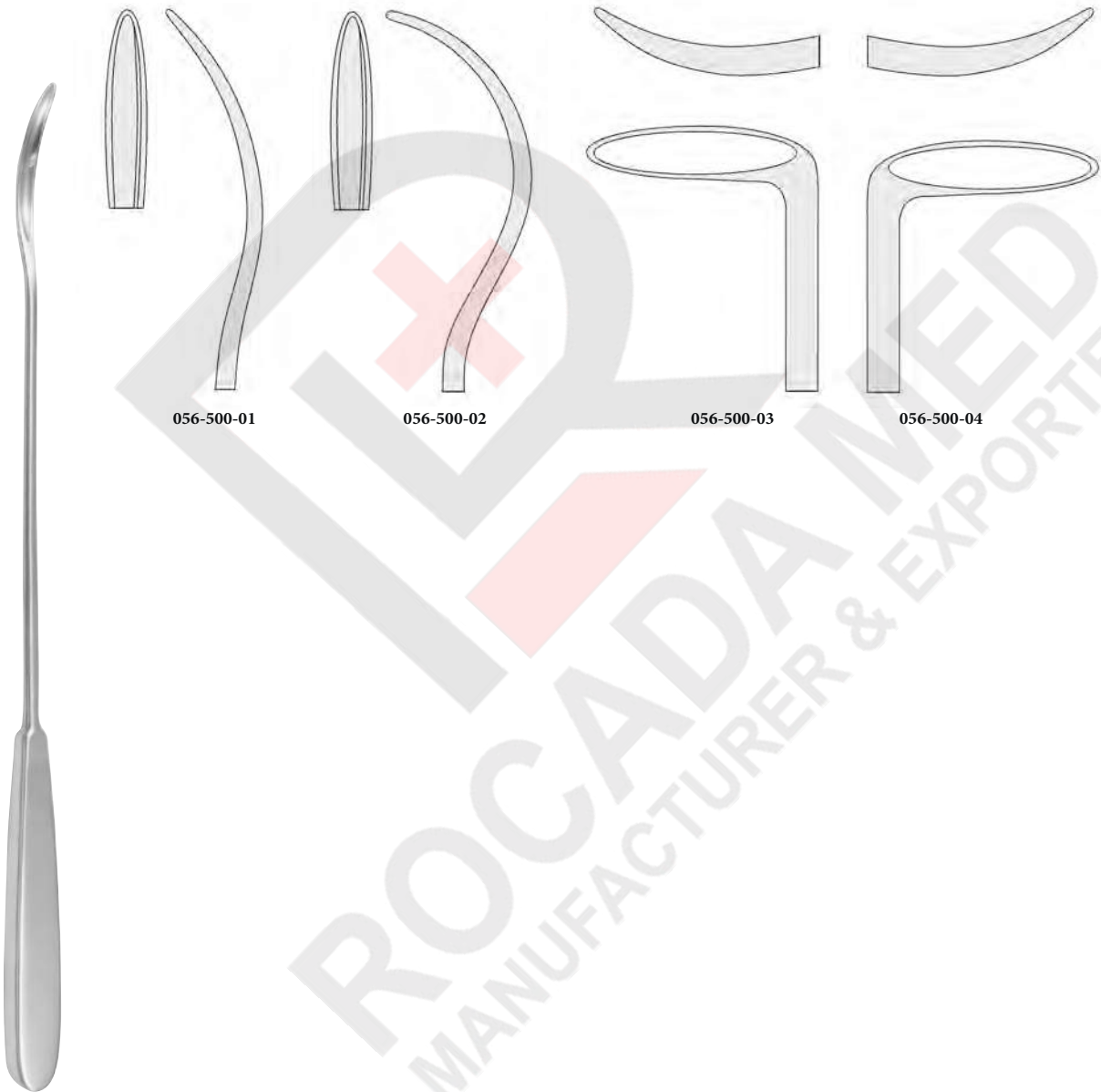

BRUNNER
30,0 cm, 11 / $\frac{3}{4}$

SURGICAL INSTRUMENTS

SURGICAL INSTRUMENTS

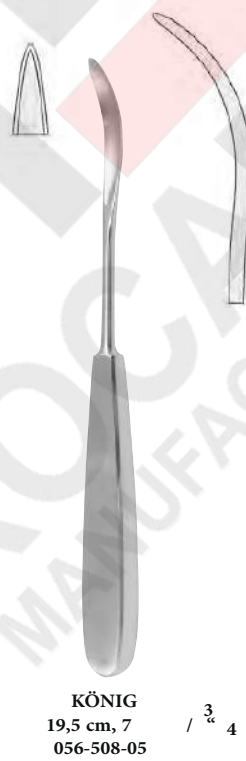
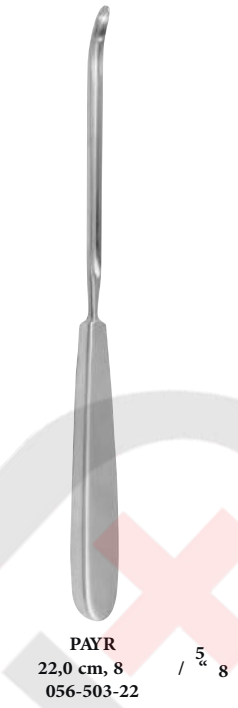



KIRSCHNER



25,5 cm, 10"
056-510-25



28,0 cm, 11"
056-510-28



BRUNNER-FERROZELL
18,0 cm, 7" 056-521-18
27,0 cm, 10 5/8" 056-521-27



KOCHER



15,0 cm, 6"
16,0 cm, 6 1/4"

056-513-15
056-513-16



056-514-15
056-514-16



18,0 cm, 7"
056-516-18

SURGICAL INSTRUMENTS



MOD. WIEN
23,5 cm, 9 / $\frac{1}{4}$ 4
056-532-23



BOZEMANN
21,0 cm, 8 / $\frac{1}{4}$ 4
056-531-21



23,0 cm, 9''
056-530-23



MICHEL
12,0 cm, 4 / $\frac{3}{4}$ 4
056-550-12



COLLIN
13,0 cm, 5''
056-552-13



RICHTER-HEATH
14,0 cm, 5 / $\frac{1}{4}$ 2
056-553-14



WACHENFELDT
12,5 cm, 5''
056-555-01



HEGENBARTH
12,5 cm, 5''
056-556-12



MICHEL
12,0 cm, 4 / ³/₄
056-558-12



LANGE
10,0 cm, 4"
056-559-10



CHILDE
18,0 cm, 7"
056-560-01



CHILDE CLIP
18,0 cm, 7"
056-560-02

SURGICAL INSTRUMENTS



MICHEL

056-570-08	7,5 x 1,75 mm
056-570-11	11,0 x 2,0 mm
056-570-12	12,0 x 3,0 mm
056-570-14	14,0 x 3,0 mm
056-570-16	16,0 x 3,0 mm
056-570-18	18,0 x 3,0 mm
056-570-20	20,0 x 3,0 mm
056-570-22	22,0 x 3,0 mm



CLIP-SET
056-558-00
bestehend aus, consisting of,
compuesto de, composto da
1 x 056-558-12
1 x 056-550-12
50 x 056-570-14
1 x 056-590-01 (Etui)

SURGICAL INSTRUMENTS

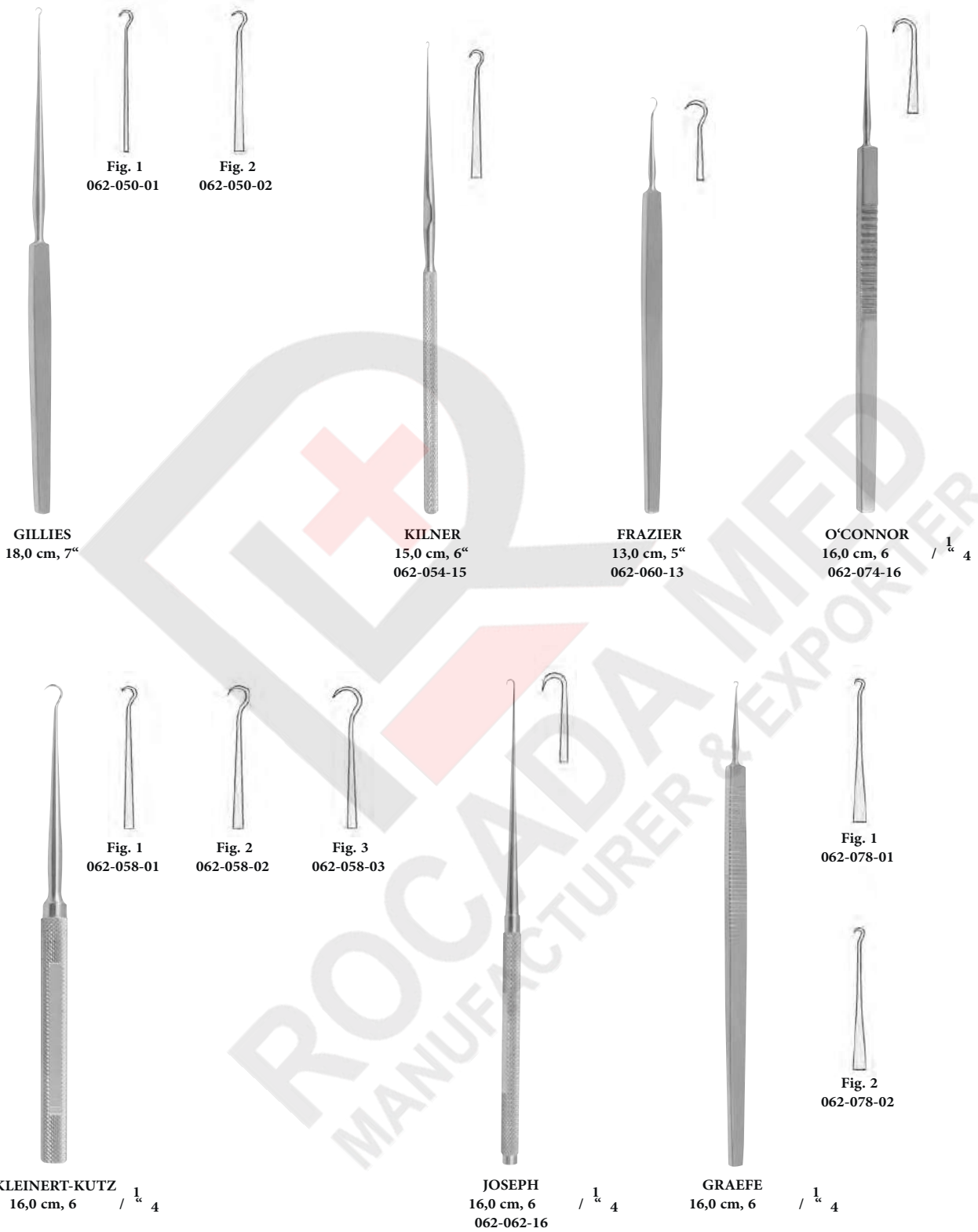



16,0 cm, 6 / $\frac{1}{4}$



Fig. 1
062-070-01



Fig. 2
062-070-02



Fig. 3
062-070-03



Fig. 4
062-070-04



GUTHRIE
16,0 cm, 6 / $\frac{1}{4}$



Fig. 1
062-080-01



Fig. 2
062-080-02



JOSEPH
16,0 cm, 6 / $\frac{1}{4}$



Fig. 1
062-086-01



Fig. 2
062-086-02

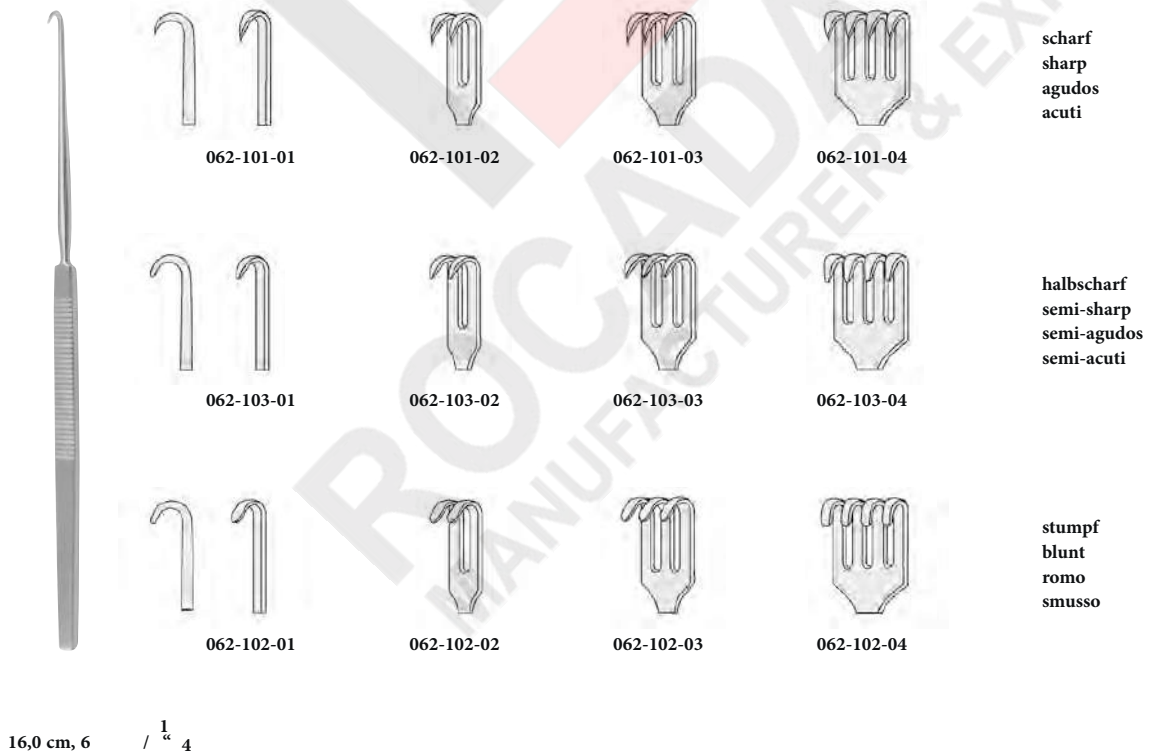
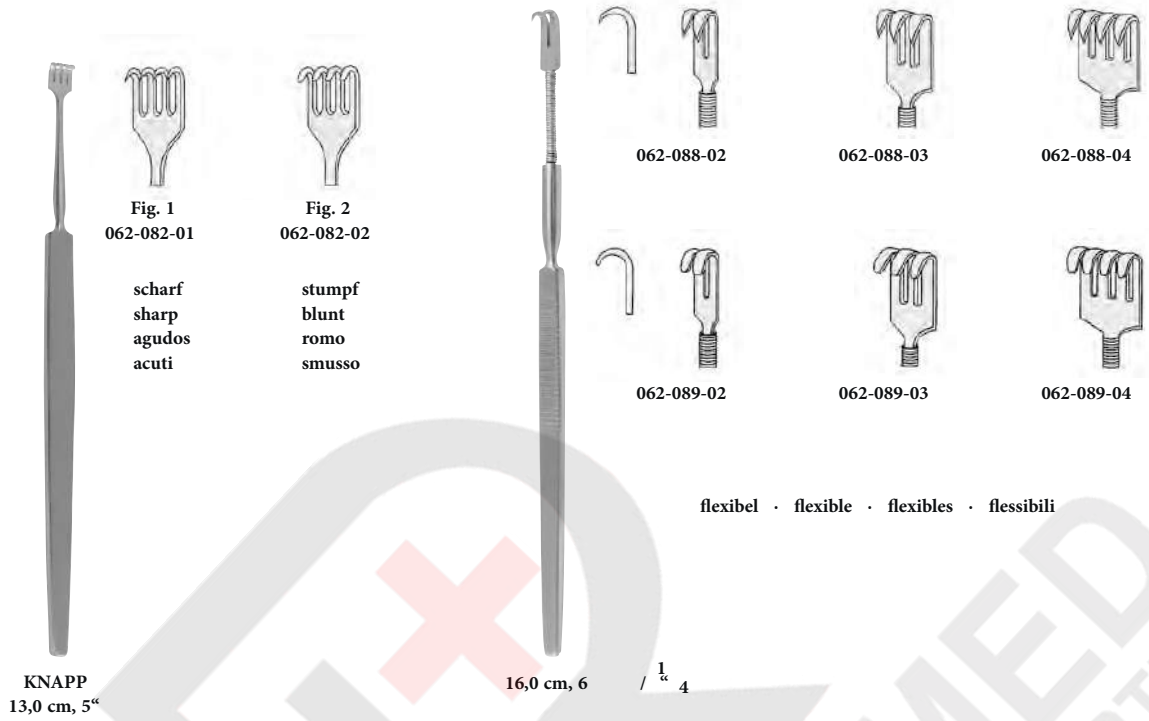

Fig. 3
062-086-03



Fig. 4
062-086-04

SURGICAL INSTRUMENTS



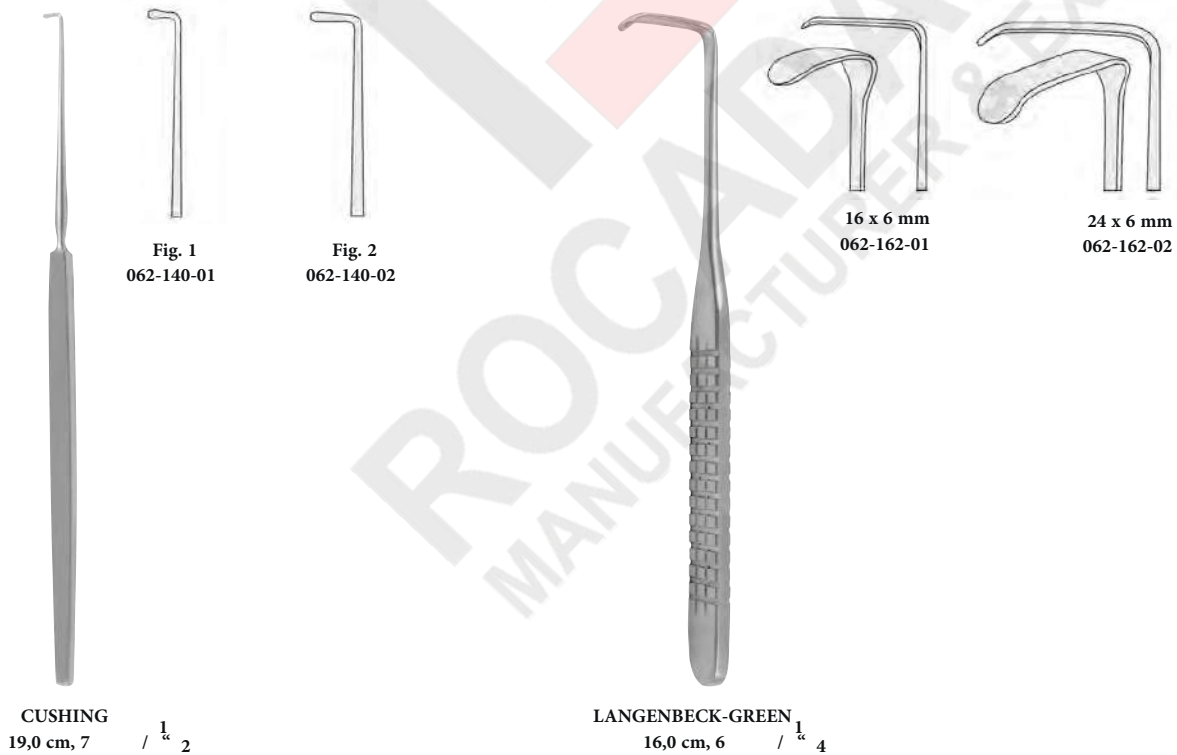
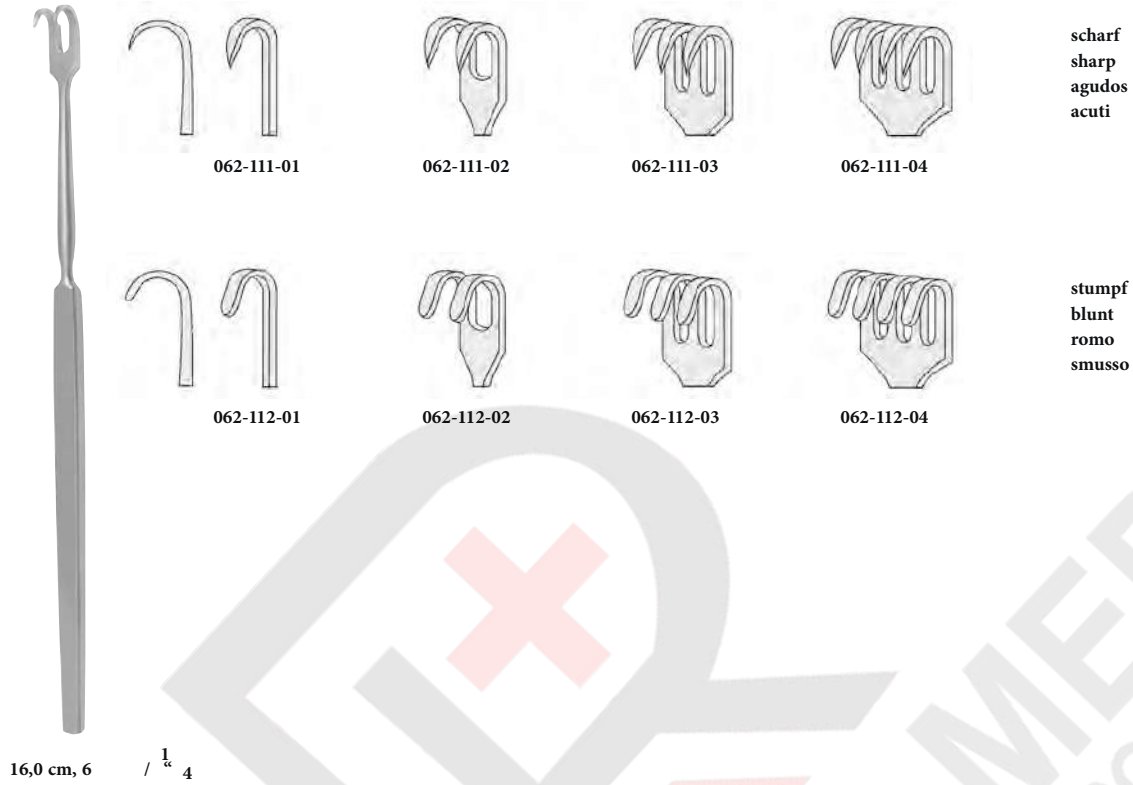

SURGICAL INSTRUMENTS

SURGICAL INSTRUMENTS

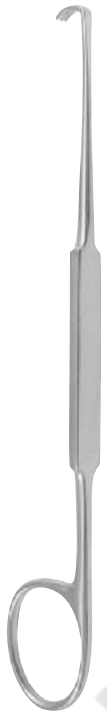

MEYERDING
18,0 cm, 7"



18 x 7 mm
062-150-01



16 x 5 mm
062-150-02



7 x 4 mm
062-150-03



10 x 3 mm
062-150-04



7 x 4 mm
062-150-05



4 x 10 mm
062-150-06



14 x 8 mm
062-166-16

16,0 cm, 6" / $\frac{1}{4}$ " 4



SENN-GREEN
15,0 cm, 6"



10 x 6 mm
062-160-10



20 x 6 mm
062-160-20



10 x 6 mm
062-164-01



17 x 5 mm
062-164-02



MINI-LANGENBECK
16,0 cm, 6" / $\frac{1}{4}$ " 4



20 x 6 mm
062-164-03



22 x 8 mm
062-164-04

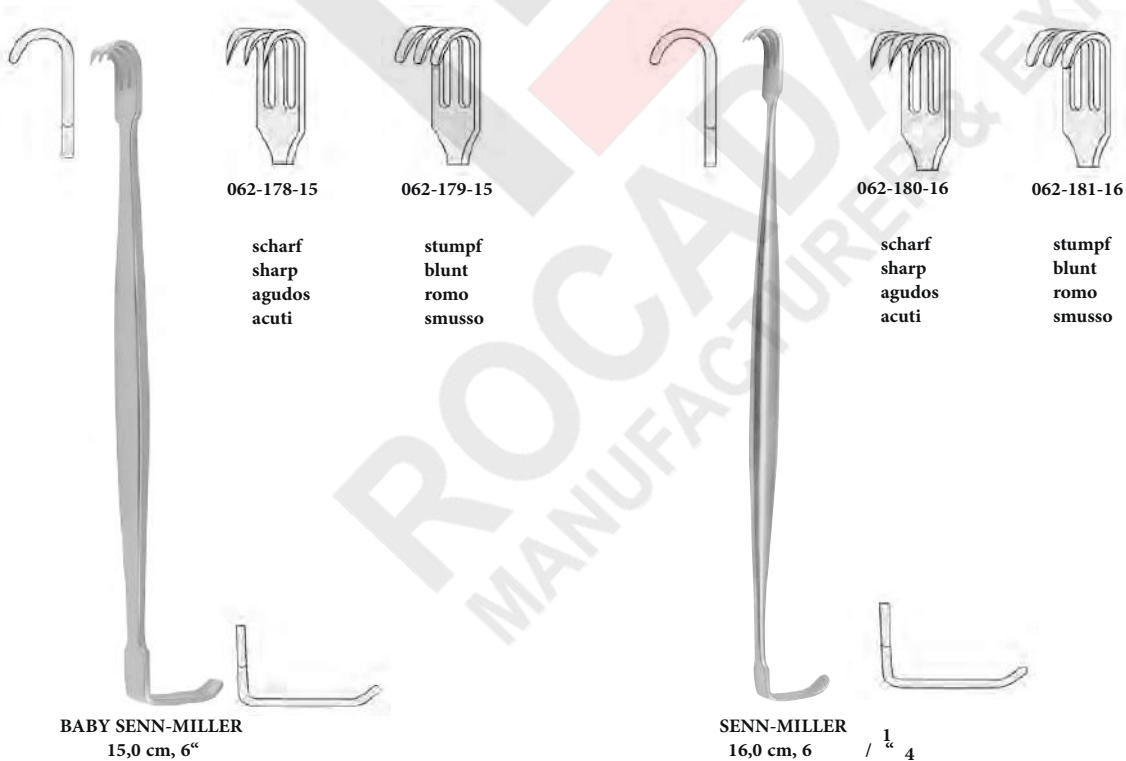
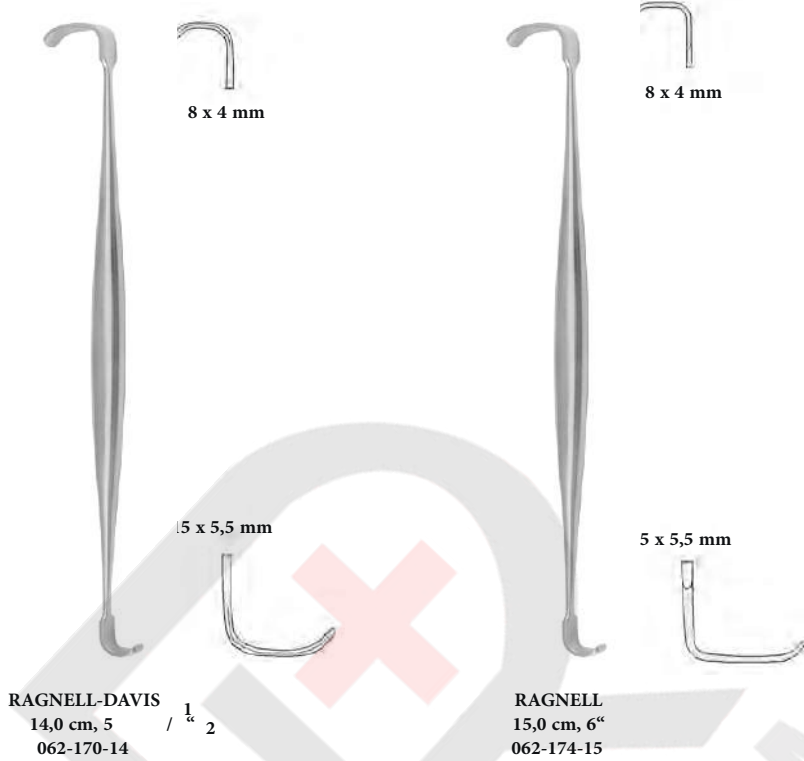

SURGICAL INSTRUMENTS

SURGICAL INSTRUMENTS

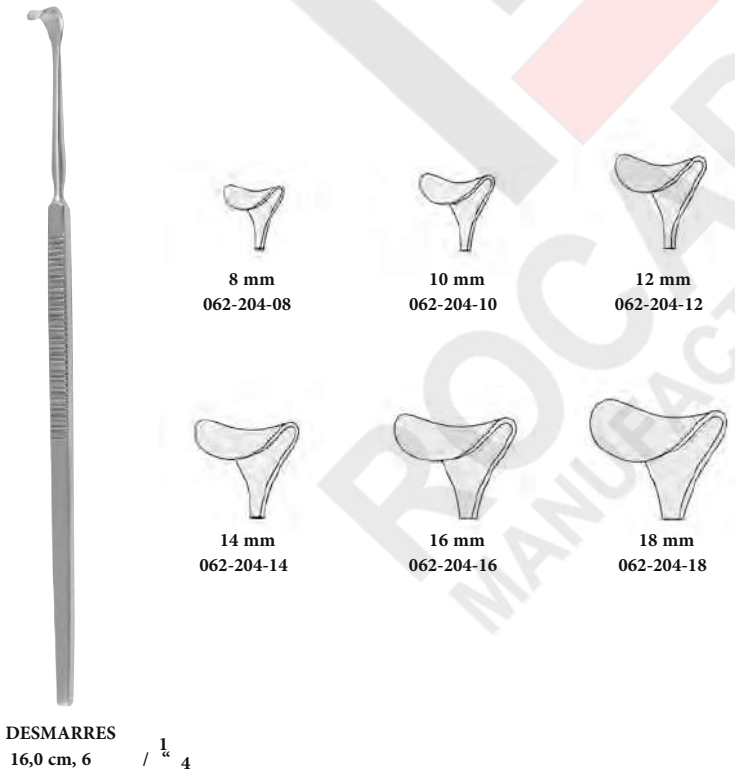
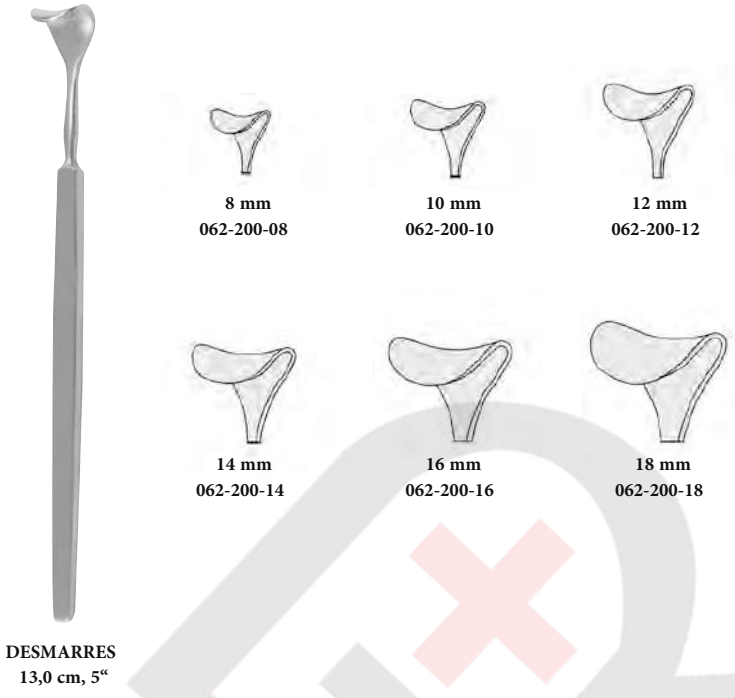



CUSHING
20,0 cm, 8"



8 mm
062-210-08



10 mm
062-210-10



12 mm
062-210-12



14 mm
062-210-14



16 mm
062-210-16



18 mm
062-210-18



CUSHING
24,0 cm, 9" / $\frac{1}{4}$ 2



8 mm
062-212-08



10 mm
062-212-10



12 mm
062-212-12



14 mm
062-212-14



16 mm
062-212-16



18 mm
062-212-18

SURGICAL INSTRUMENTS

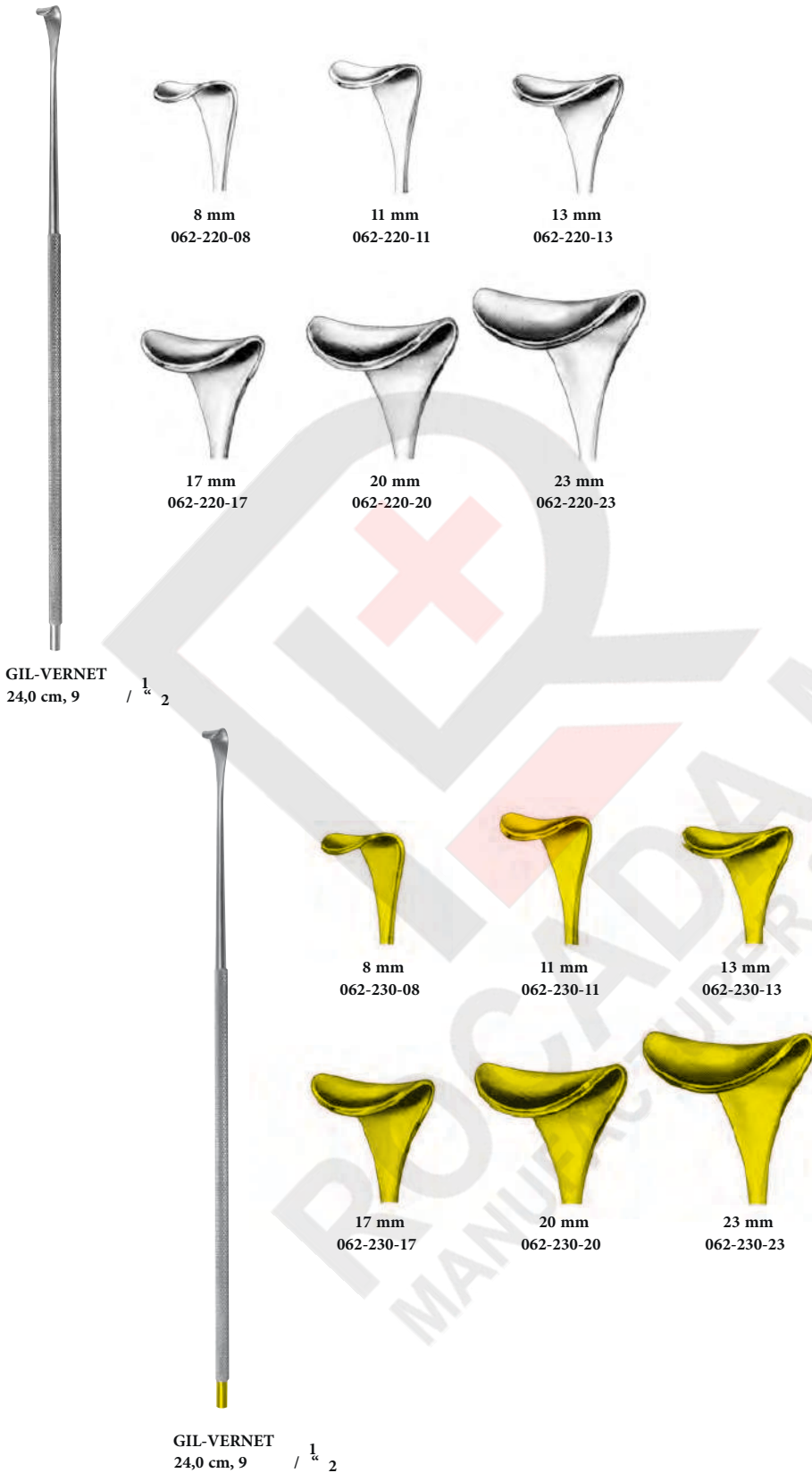



ROUX

- Fig. 1 24 x 20 mm
- Fig. 2 29 x 26 mm
- Fig. 3 33 x 29 mm
- Fig. 4 29 x 24 mm

Satz, Fig. 1-3
Set, fig. 1-3
Juego, fig. 1-3
Serie, fig. 1-3

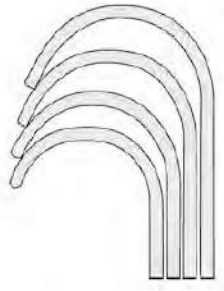

- Fig. 1 30 x 28 mm
- Fig. 2 36 x 36 mm
- Fig. 3 38 x 43 mm
- Fig. 4 45 x 28 mm

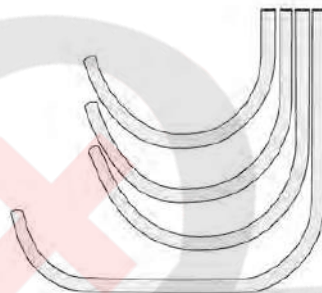

Fig. 1-3	17,0 cm, 6"	$\frac{3}{4}$ "	062-310-00
Fig. 1	14,0 cm, 5"	$\frac{1}{2}$ "	062-310-01
Fig. 2	15,0 cm, 6"		062-310-02
Fig. 3	17,0 cm, 6"	$\frac{3}{4}$ "	062-310-03
Fig. 4	18,0 cm, 7"		062-310-04



FARABEU
12,0 cm, 4"
062-300-12

$\frac{3}{4}$ "

- Fig. 2 30 x 10 mm
- Fig. 1 26 x 10 mm



- Fig. 1 30 x 13 mm
- Fig. 2 34 x 13 mm

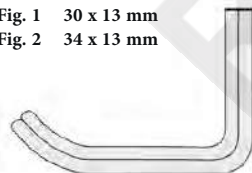

FARABEU
15,0 cm, 5"
062-302-15

$\frac{3}{4}$ "

- Fig. 2 23 x 16 mm
- Fig. 1 27 x 16 mm

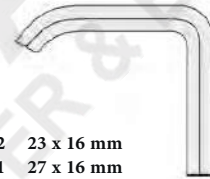

- Fig. 1 26 x 16 mm
- Fig. 2 30 x 16 mm

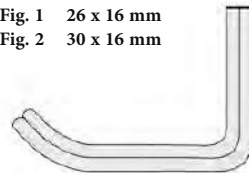

SURGICAL INSTRUMENTS

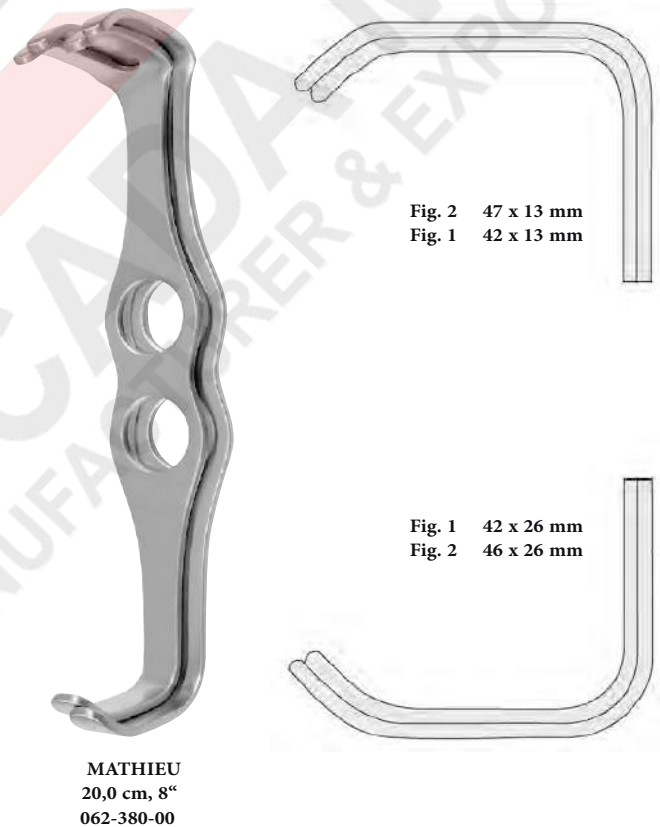
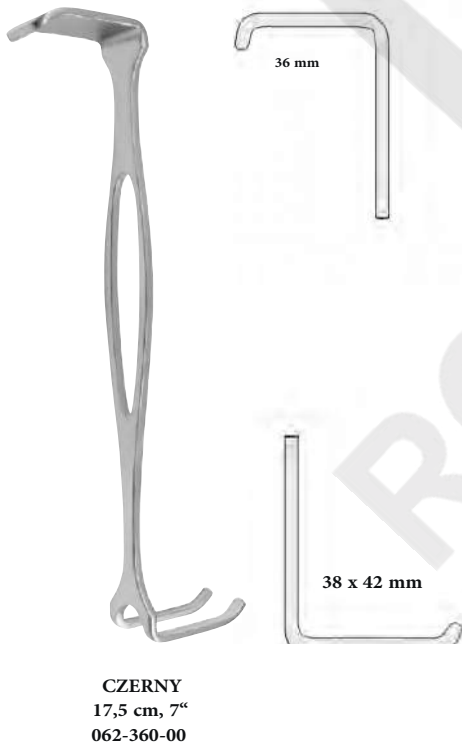
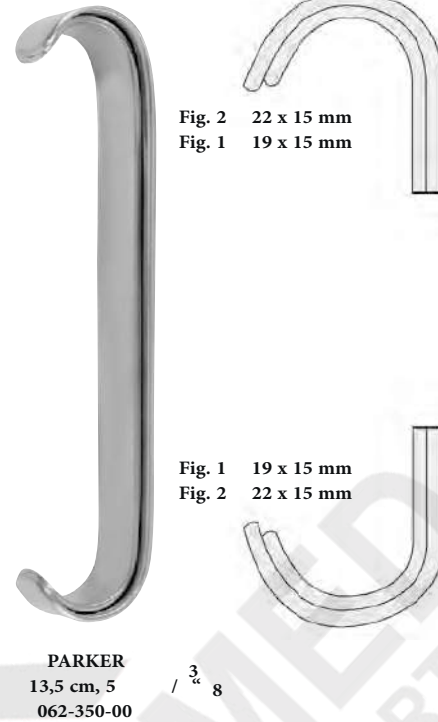
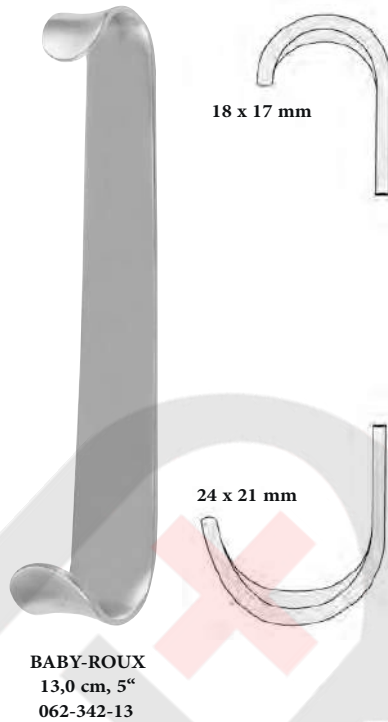
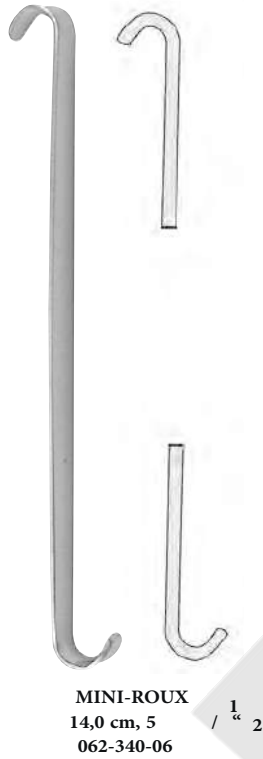

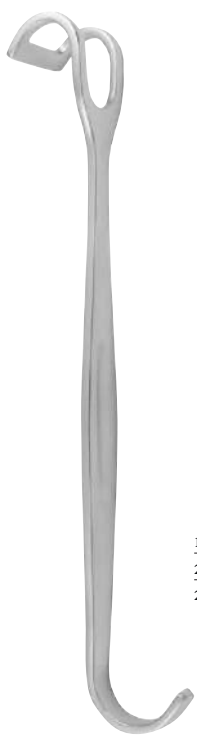
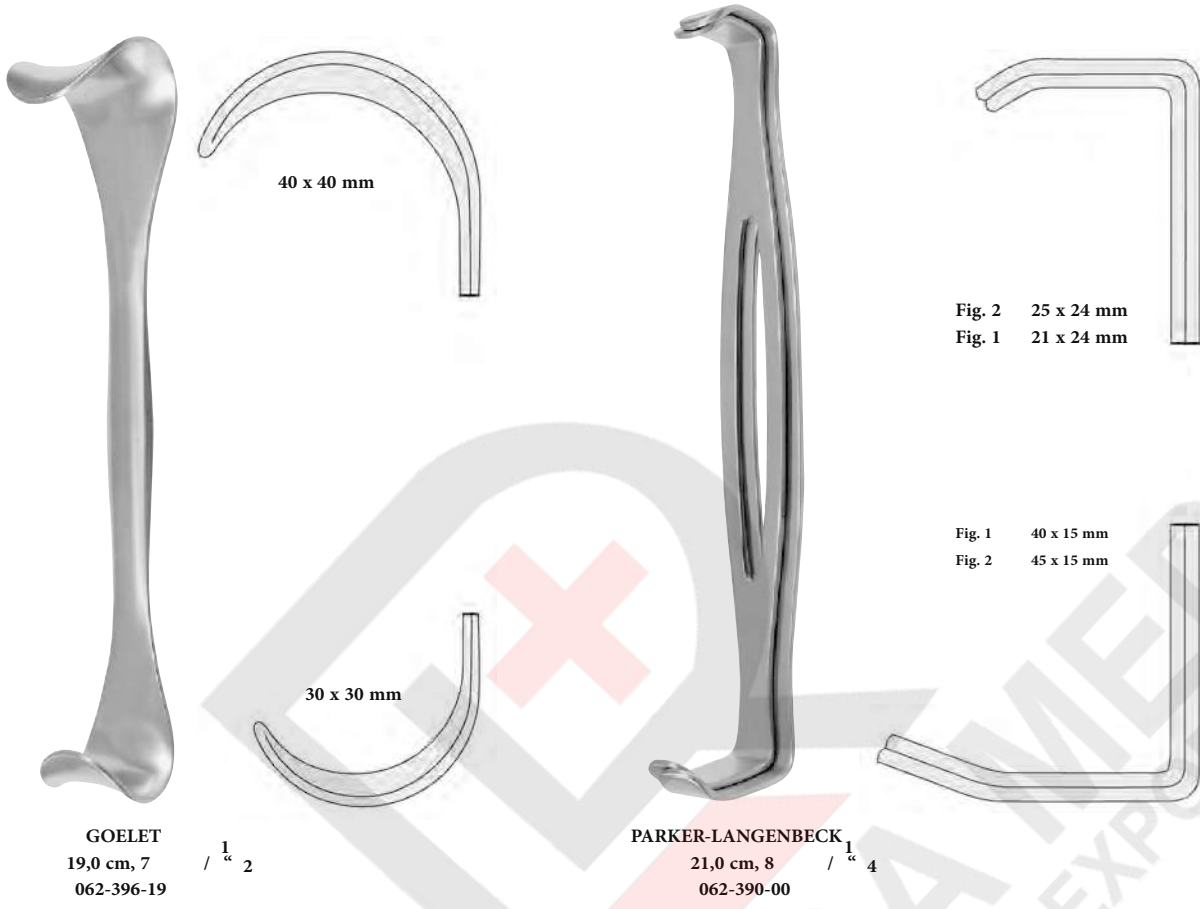

CANNY RYAL

16 mm	19,0 cm, 7	$\frac{1}{2}$ "	062-370-16
20 mm	19,0 cm, 7	$\frac{1}{2}$ "	062-370-20
25 mm	20,0 cm, 8"		062-370-25

SURGICAL INSTRUMENTS

SURGICAL INSTRUMENTS



VOLKMANN
21,5 cm, 8 1/2"



064-001-01



9 x 8 mm
064-001-02



9 x 13 mm
064-001-03



scharf
sharp
agudos
acuti



9 x 19 mm
064-001-04



9 x 29 mm
064-001-06

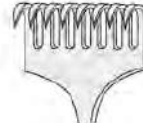

9 x 40 mm
064-001-08



VOLKMANN
21,5 cm, 8 1/2"



064-003-01



9 x 8 mm
064-003-02



9 x 13 mm
064-003-03



halbscharf
semi-sharp
semi-agudos
semi-acuti



9 x 19 mm
064-003-04



9 x 29 mm
064-003-06



9 x 40 mm
064-003-08



VOLKMANN
21,5 cm, 8 / $\frac{1}{2}$



064-002-01



9 x 8 mm
064-002-02



9 x 13 mm
064-002-03



9 x 19 mm
064-002-04



9 x 29 mm
064-002-06



9 x 40 mm
064-002-08

stumpf
blunt
romo
smusso



KOCHER
22,0 cm, 8 / $\frac{5}{8}$



064-011-01



9 x 8 mm
064-011-02



15 x 15 mm
064-011-03



15 x 20 mm
064-011-04



15 x 30 mm
064-011-06

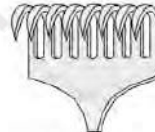

15 x 40 mm
064-011-08

scharf
sharp
agudos
acuti

SURGICAL INSTRUMENTS

SURGICAL INSTRUMENTS



KOCHER
22,0 cm, 8 / 5 8



064-013-01



9 x 8 mm
064-013-02



15 x 15 mm
064-013-03

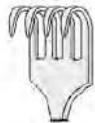

15 x 20 mm
064-013-04



15 x 30 mm
064-013-06



15 x 40 mm
064-013-08

halbscharf
semi-sharp
semi-agudos
semi-acuti



KOCHER
22,0 cm, 8 / 5 8



064-012-01



9 x 8 mm
064-012-02



15 x 15 mm
064-012-03



15 x 20 mm
064-012-04



15 x 30 mm
064-012-06



15 x 40 mm
064-012-08

stumpf
blunt
romo
smusso

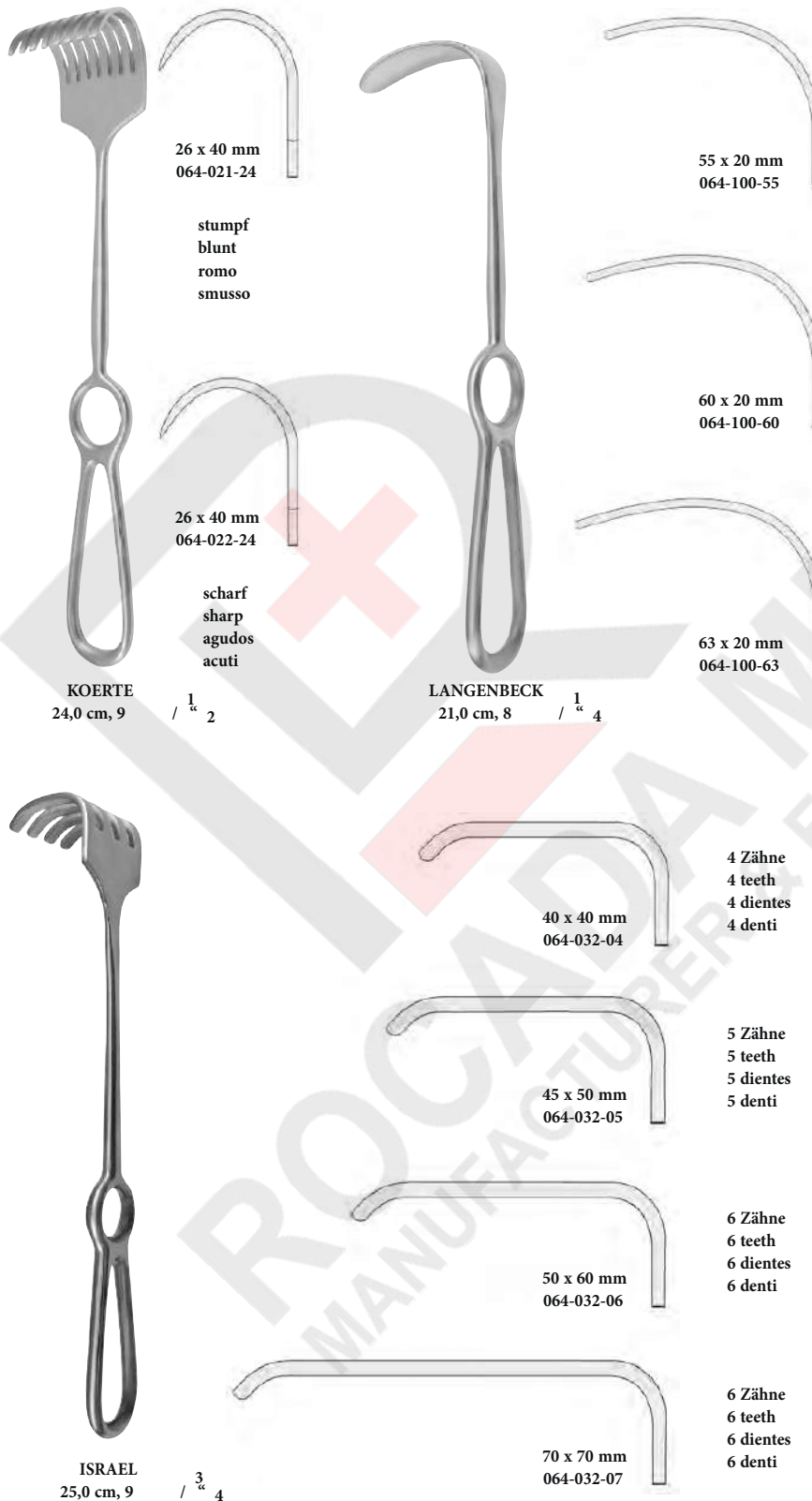

SURGICAL INSTRUMENTS

SURGICAL INSTRUMENTS



LANGENBECK
22,0 cm, 8 / 5 8



30 x 11 mm
064-110-30



30 x 14 mm
064-110-31



30 x 16 mm
064-110-32



40 x 11 mm
064-110-40



50 x 11 mm
064-110-50



LANGENBECK
22,0 cm, 8 / 5 8

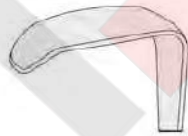

30 x 11 mm
064-120-30



30 x 14 mm
064-120-31



30 x 16 mm
064-120-32



40 x 11 mm
064-120-40

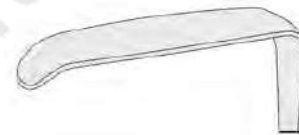

50 x 11 mm
064-120-50



KOCHER-LANGENBECK
21,5 cm, 8 / 2



22 x 6 mm
064-130-22



25 x 6 mm
064-130-25



25 x 8 mm
064-130-26



35 x 8 mm
064-130-35



35 x 11 mm
064-130-36



35 x 15 mm
064-130-37



40 x 11 mm
064-130-40



70 x 14 mm
064-130-70



80 x 12 mm
064-130-80



80 x 16 mm
064-130-85

SURGICAL INSTRUMENTS

SURGICAL INSTRUMENTS



KOCHER
23,0 cm, 9"



40 x 18 mm
064-140-18



60 x 20 mm
064-140-20



60 x 25 mm
064-140-25



75 x 30 mm
064-140-30



75 x 40 mm
064-140-40



SAUERBRUCH
22,5 cm, 8" / $\frac{3}{4}$ "



44 x 16 mm
064-150-44



55 x 22 mm
064-150-55



72 x 19 mm
064-150-72



MIDDELDORPF



21,5 cm, 8 / $\frac{1}{4}$ 2
14 x 17 mm
064-180-01



22,0 cm, 8 / $\frac{5}{8}$ 8
20 x 22 mm
064-180-02



23,5 cm, 9 / $\frac{1}{4}$ 4
26 x 30 mm
064-180-03



MIDDELDORPF



21,5 cm, 8 / $\frac{1}{4}$ 2
14 x 17 mm
064-182-01



22,0 cm, 8 / $\frac{5}{8}$ 8
20 x 22 mm
064-182-02



23,5 cm, 9 / $\frac{1}{4}$ 4
26 x 30 mm
064-182-03



RICHARDSON (KELLY)
24,0 cm, 9 / $\frac{1}{4}$ 2



28 x 20 mm
064-210-02



36 x 28 mm
064-210-03



44 x 38 mm
064-210-04

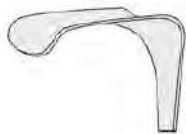

52 x 22 mm
064-210-05



65 x 50 mm
064-210-06

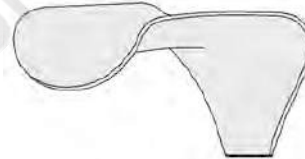

70 x 65 mm
064-210-07

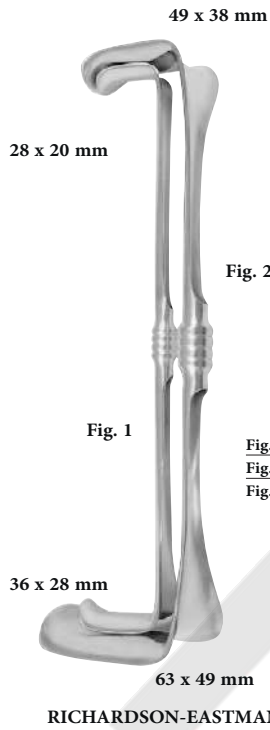
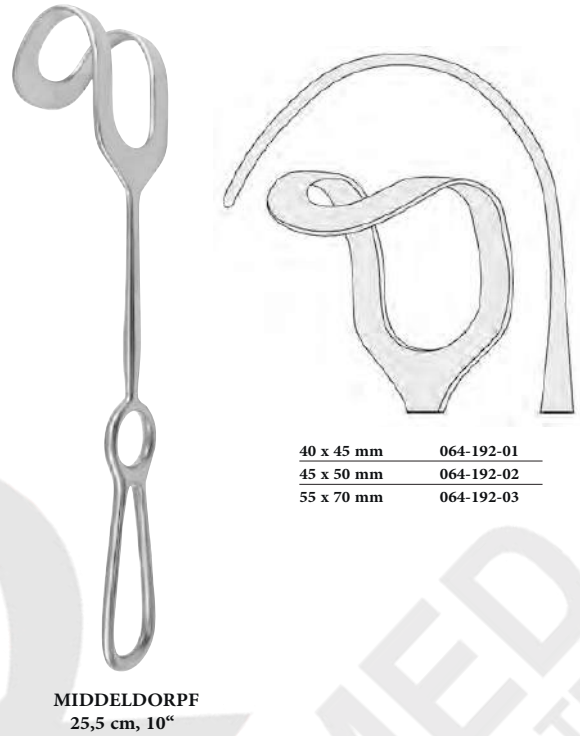
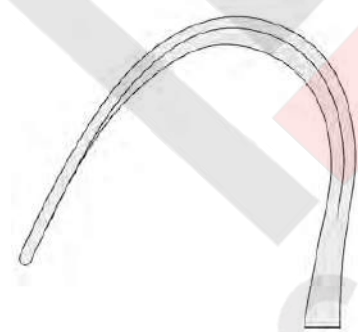
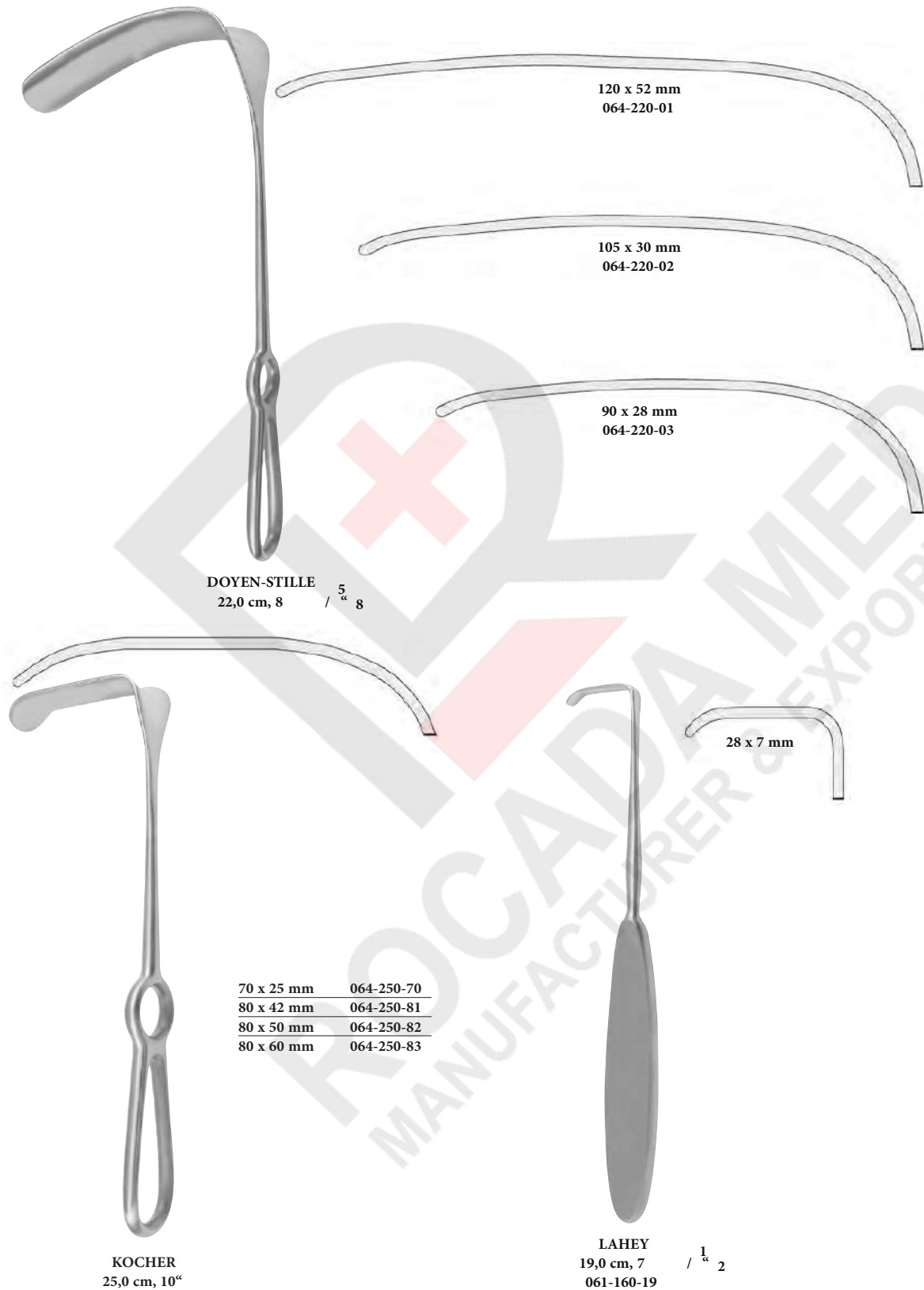

Fig. 1+2	28,0 cm, 1 1"	062-200-00
Fig. 1	26,0 cm, 10 1/4"	062-200-01
Fig. 2	28,0 cm, 1 1"	062-200-02



45 x 40 mm	064-240-40
45 x 50 mm	064-240-50
45 x 60 mm	064-240-60
55 x 75 mm	064-240-75
65 x 85 mm	064-240-85





SURGICAL INSTRUMENTS

SURGICAL INSTRUMENTS

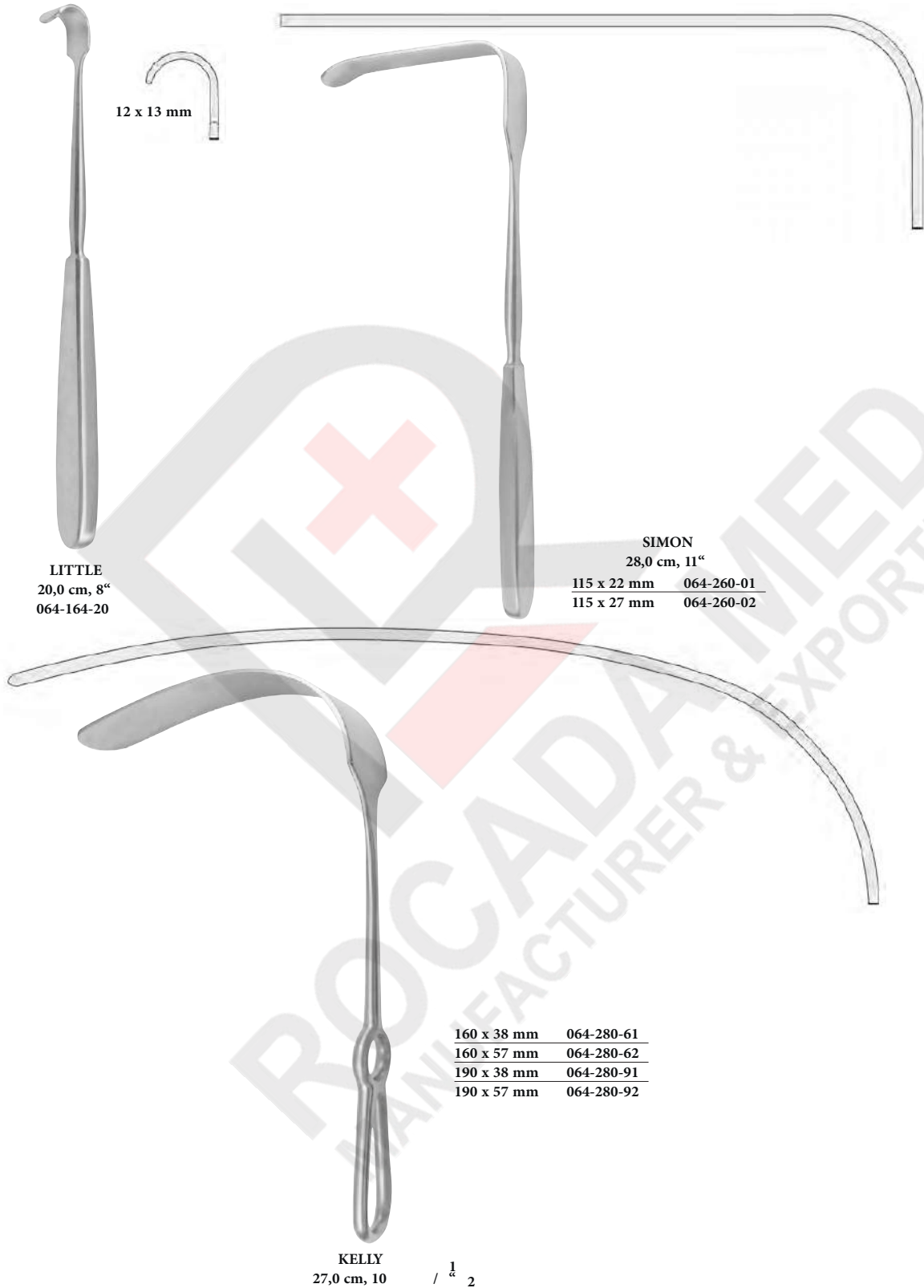

LITTLE
20,0 cm, 8"
064-164-20

SIMON
28,0 cm, 11"
115 x 22 mm 064-260-01
115 x 27 mm 064-260-02

160 x 38 mm 064-280-61
160 x 57 mm 064-280-62
190 x 38 mm 064-280-91
190 x 57 mm 064-280-92

KELLY
27,0 cm, 10" / 1/2



185 x 35 mm	064-274-01
120 x 50 mm	064-274-02
150 x 50 mm	064-274-03

MIKULICZ
26,0 cm, 10 / $\frac{1}{4}$ 4



90 x 50 mm

MIKULICZ
26,0 cm, 10 / $\frac{1}{4}$ 4
064-272-90

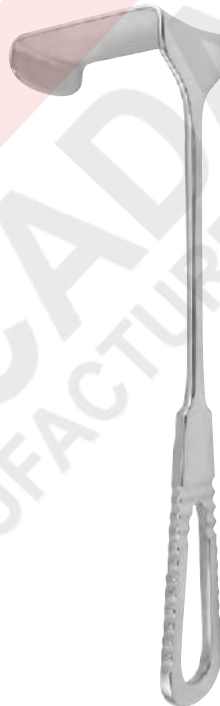

70 x 38 mm	064-290-38
70 x 50 mm	064-290-51

MORRIS
24,5 cm, 9 / $\frac{5}{8}$ 8

SURGICAL INSTRUMENTS

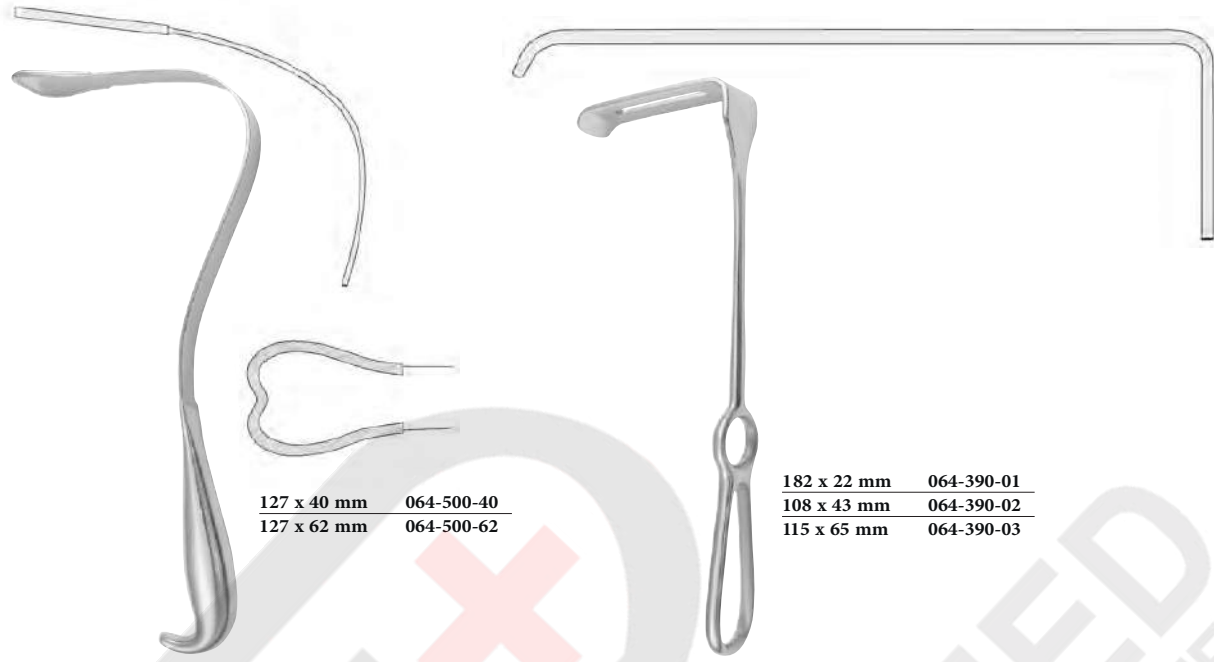

127 x 40 mm 064-500-40
127 x 62 mm 064-500-62

182 x 22 mm 064-390-01
108 x 43 mm 064-390-02
115 x 65 mm 064-390-03

HARRINGTON
32,0 cm, 12 / $\frac{1}{4}$ 2

CORYKKOS
24,0 cm, 9 / $\frac{1}{4}$ 2

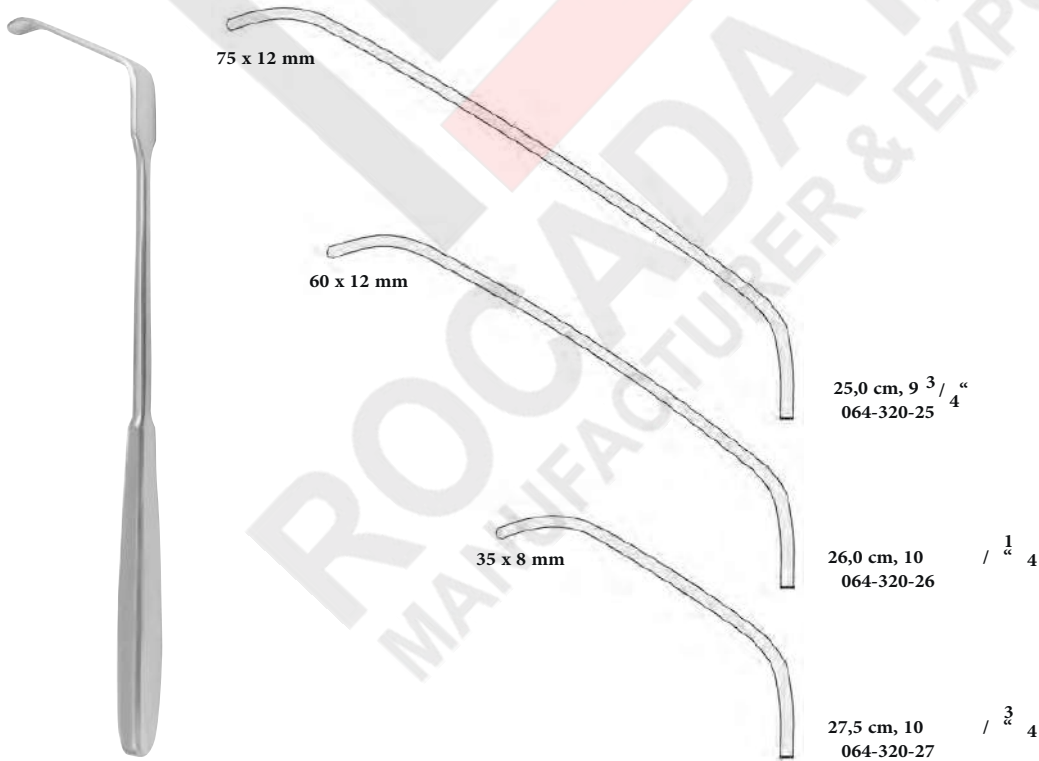

75 x 12 mm

60 x 12 mm

25,0 cm, 9 $\frac{3}{4}$ / $\frac{1}{4}$ 4
064-320-25

35 x 8 mm

26,0 cm, 10 / $\frac{1}{4}$ 4
064-320-26

27,5 cm, 10 / $\frac{3}{4}$ 4
064-320-27

ZENKER

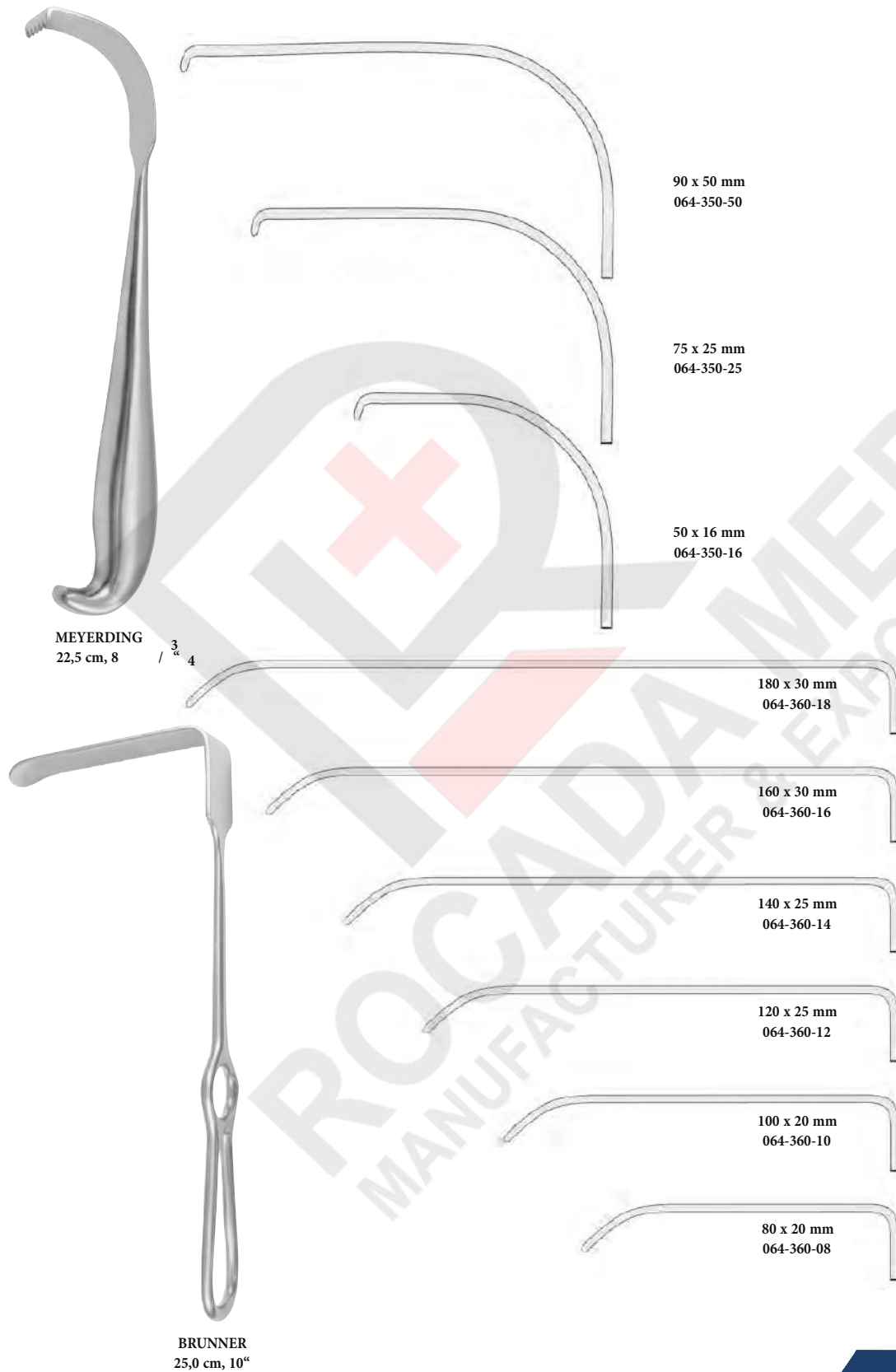

SURGICAL INSTRUMENTS

SURGICAL INSTRUMENTS

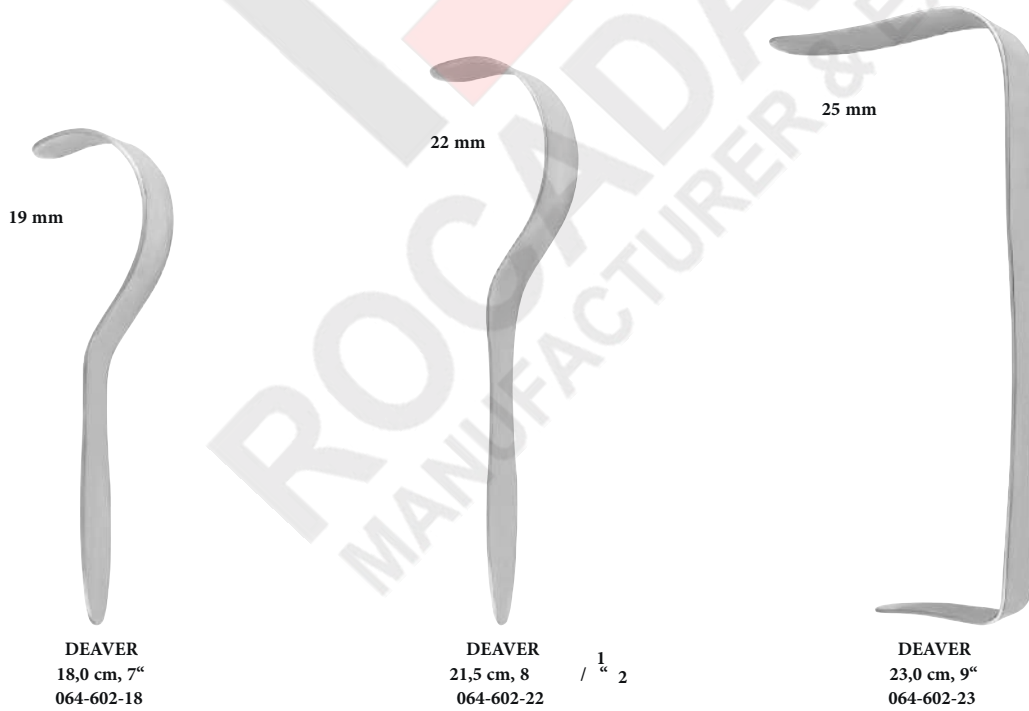
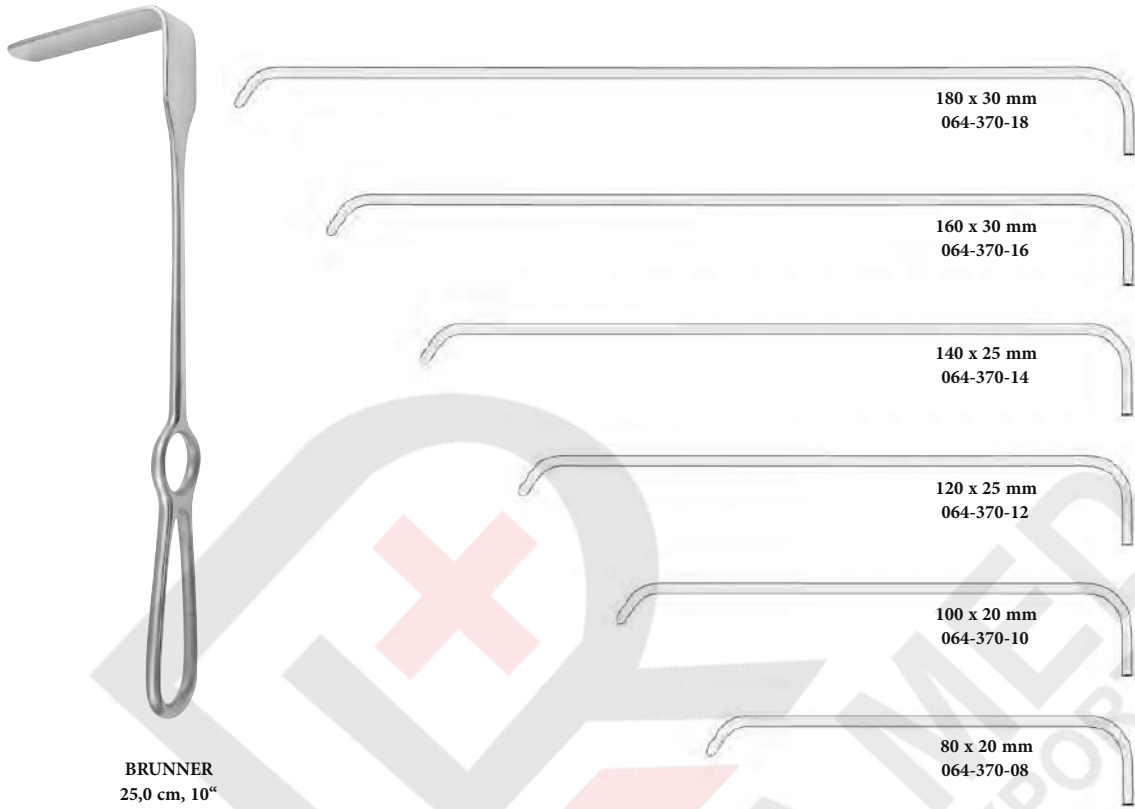

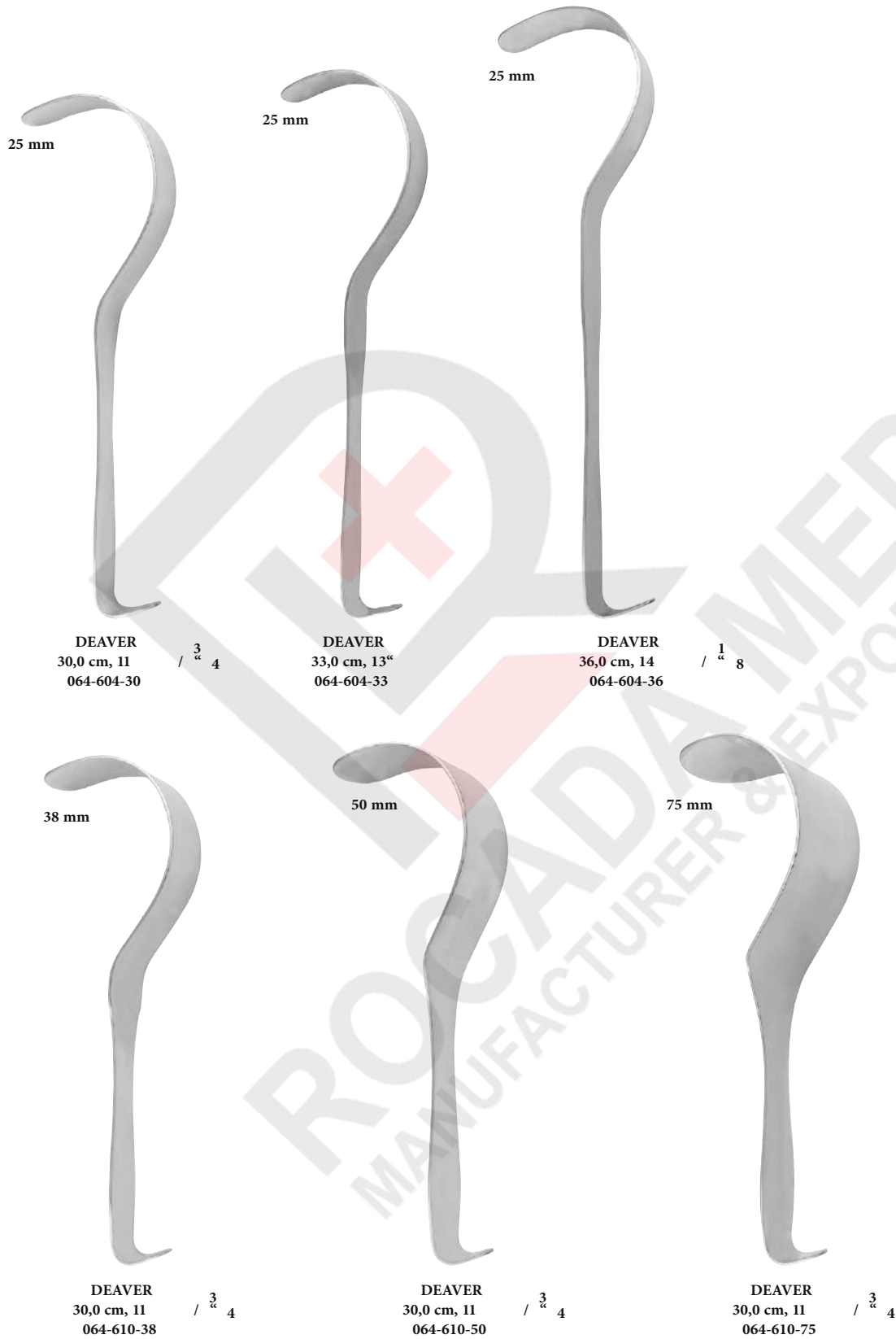

SURGICAL INSTRUMENTS

SURGICAL INSTRUMENTS

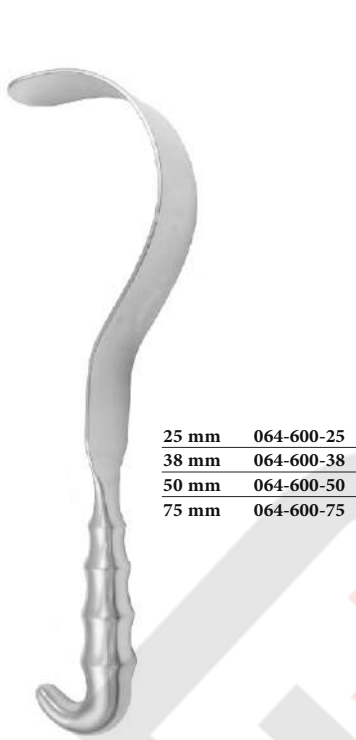

25 mm	064-600-25
38 mm	064-600-38
50 mm	064-600-50
75 mm	064-600-75

DEAVER
30,0 cm, 11 / $\frac{3}{4}$



40 mm	30,0 cm, 1 1/4"	064-700-30
54 mm	32,0 cm, 12 1/2"	064-700-32

ALLISON



75 x 50 mm	16,0 cm, 6 1/4"	064-710-50
75 x 90 mm	16,0 cm, 6 1/4"	064-710-90

DAVIDSON



ST MARKS

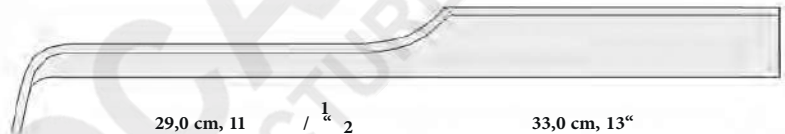

29,0 cm, 11	/ $\frac{1}{4}$	2
130 x 60 mm		
064-720-01		

33,0 cm, 13"	
180 x 60 mm	
064-720-02	



29,0 cm, 11	/ $\frac{1}{4}$	2
130 x 60 mm		
064-721-01		

33,0 cm, 13"	
180 x 60 mm	
064-721-02	

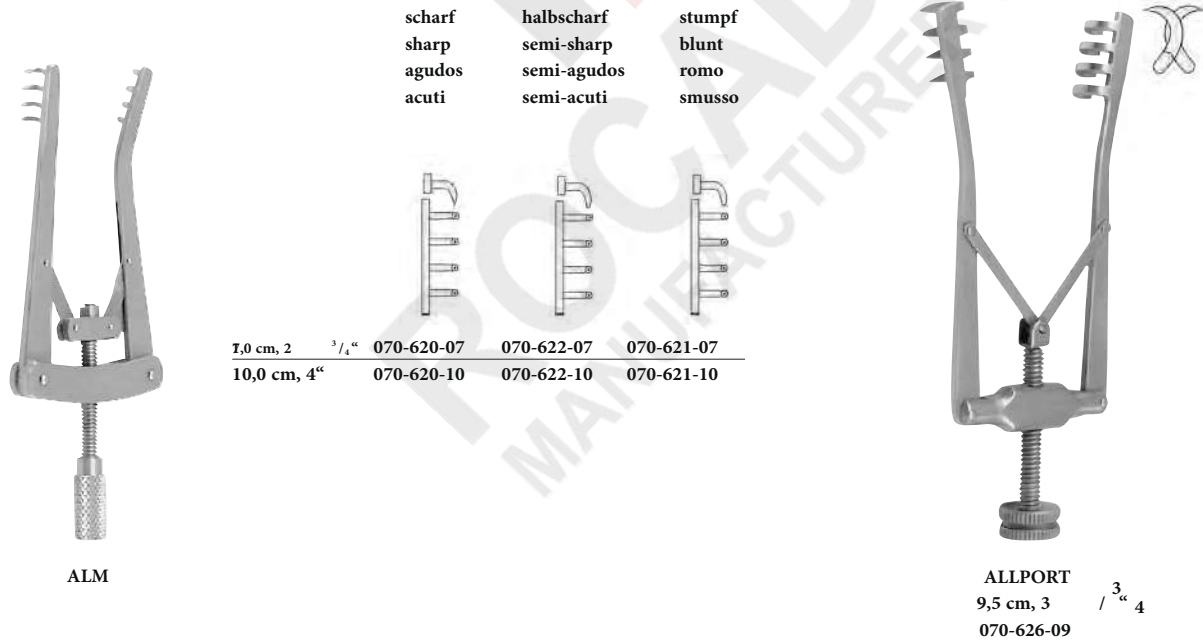
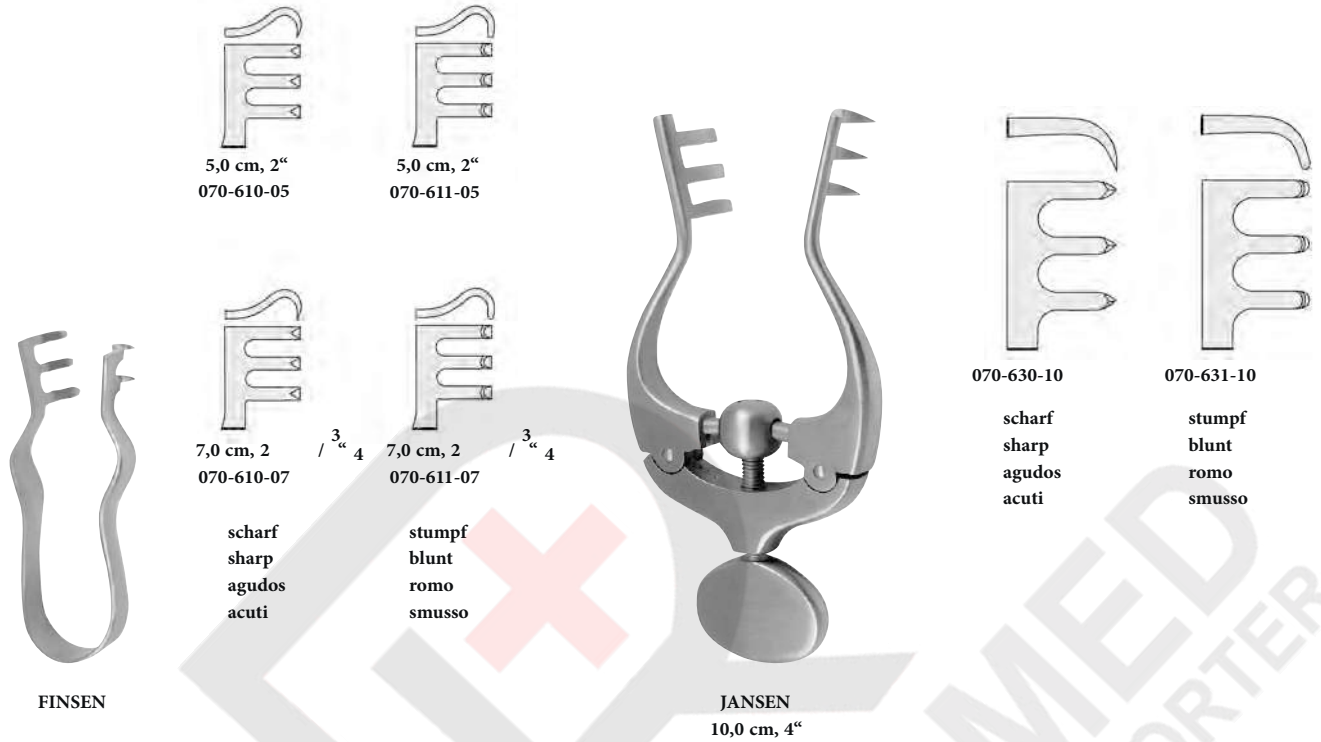

SURGICAL INSTRUMENTS

SURGICAL INSTRUMENTS

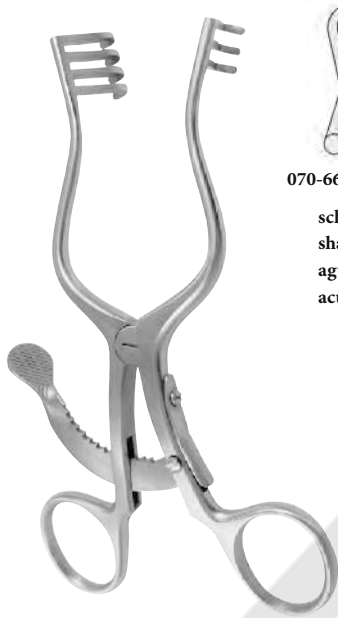

SALP-CONTOUR
14,0 cm, 5 / $\frac{1}{4}$ 2



ADSON-BABY
16,0 cm, 6 / $\frac{1}{4}$ 4



ANDERSON-ADSON
19,0 cm, 8"

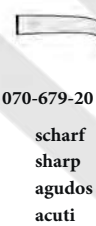

ADSON
26,5 cm, 10 / $\frac{1}{4}$ 2





MOLLISON
15,5 cm, 6"
070-674-15



scharf
sharp
agudos
acuti



SCHUHKNECHT
12,5 cm, 5"



070-800-12
scharf
sharp
agudos
acuti



070-801-12
stumpf
blunt
romo
smuss

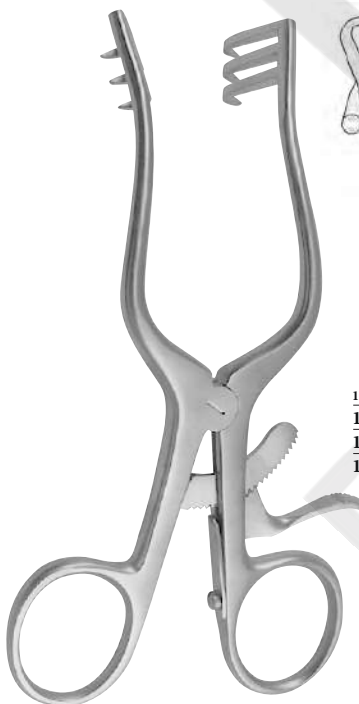

WULLSTEIN



scharf
sharp
agudos
acuti

stumpf
blunt
romo
smusso

10,5 cm, 4 1/8"	070-810-10	070-81 1-10
13,0 cm, 5"	070-810-13	070-81 1-13
15,0 cm, 6"	070-810-15	070-81 1-15
18,0 cm, 7"	070-810-18	070-81 1-18

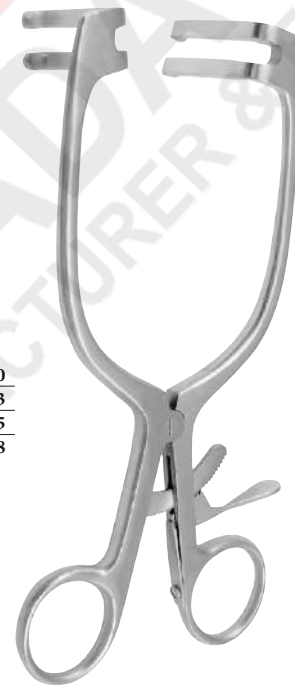

MAYO-ADAMS
16,5 cm, 6 1/4"
070-822-17

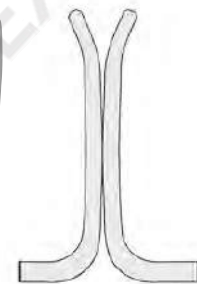

SURGICAL INSTRUMENTS

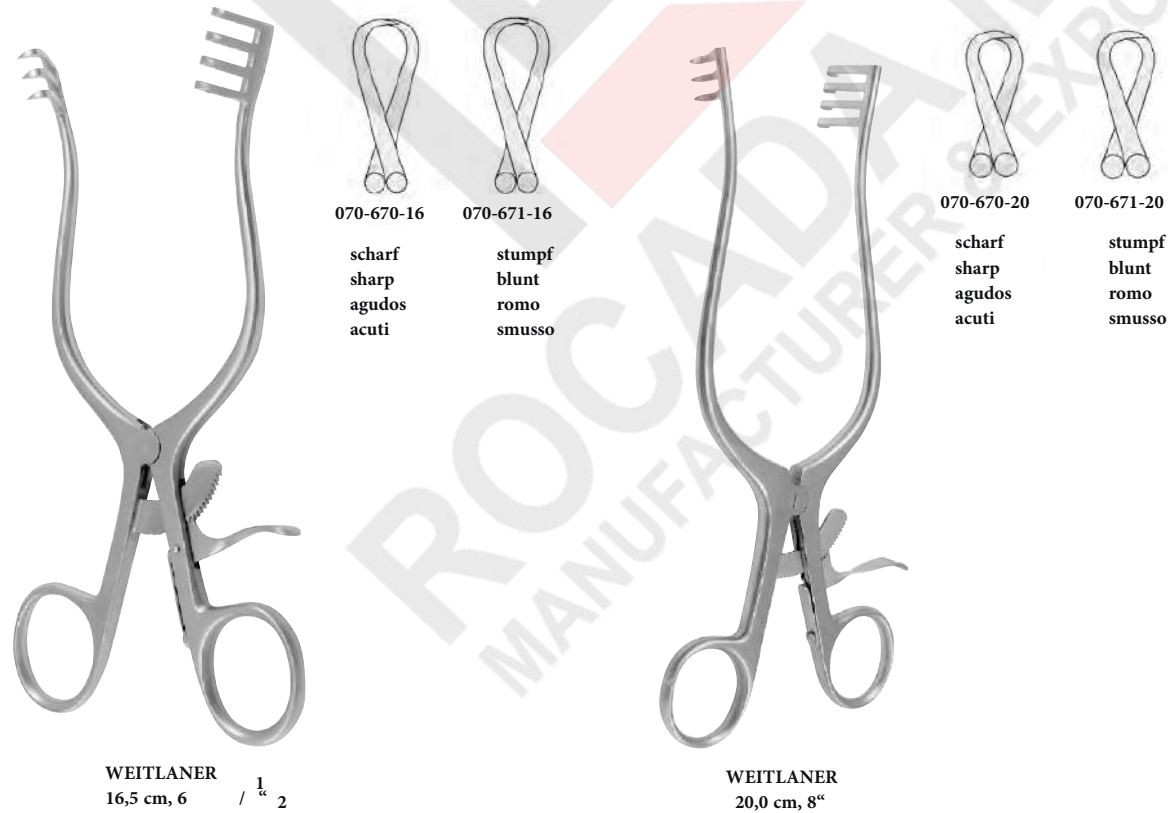
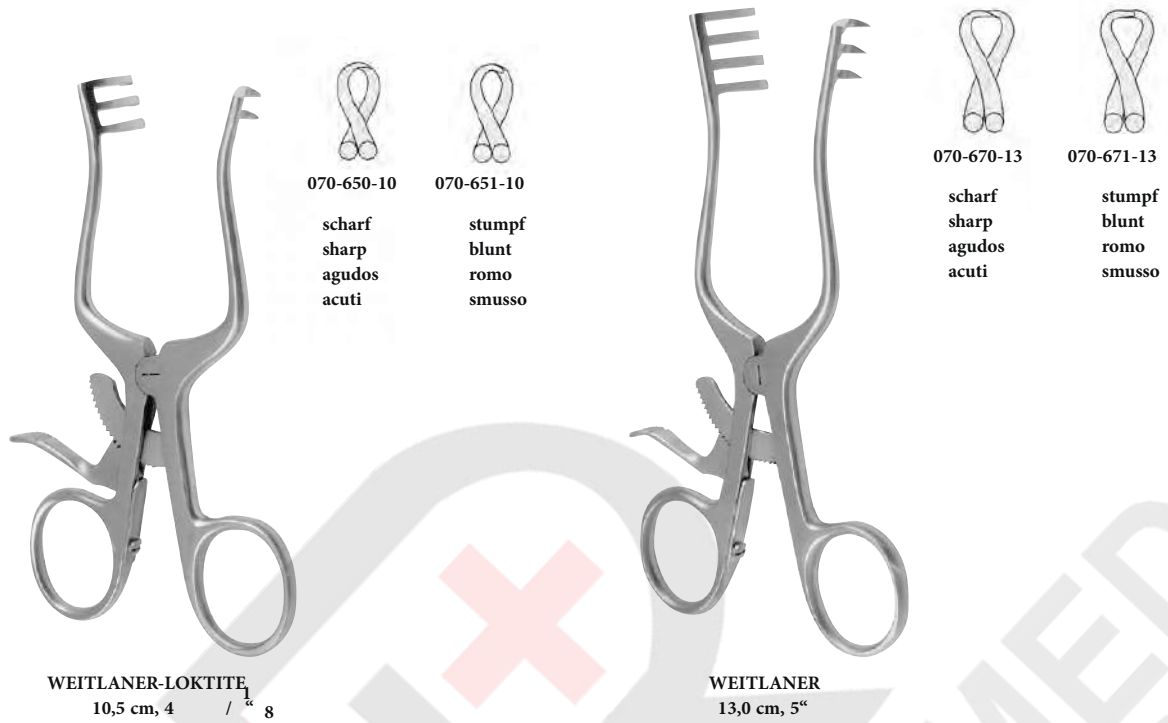

SURGICAL INSTRUMENTS



WEITLANER-BABY
 13,0 cm, 5"
 070-850-13



**ADSON
 (CONE)**

20,0 cm, 8"	070-860-20	070-861-20
26,0 cm, 10 1/4"	070-860-26	070-861-26

scharf	stumpf
sharp	blunt
agudos	romo
acuti	smusso

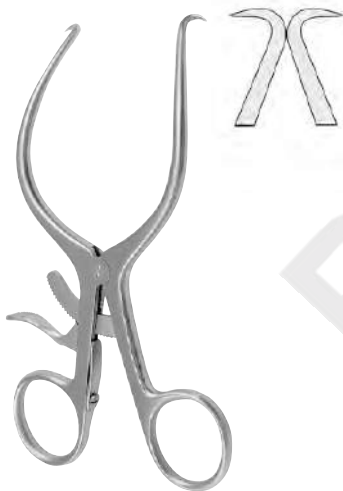

GELPI
 13,5 cm, 5 3/8"
 070-202-14



GELPI
 19,0 cm, 7 1/2"
 070-202-19



GELPI-LOKTITE
 18,0 cm, 7 1/4"
 070-250-19

SURGICAL INSTRUMENTS

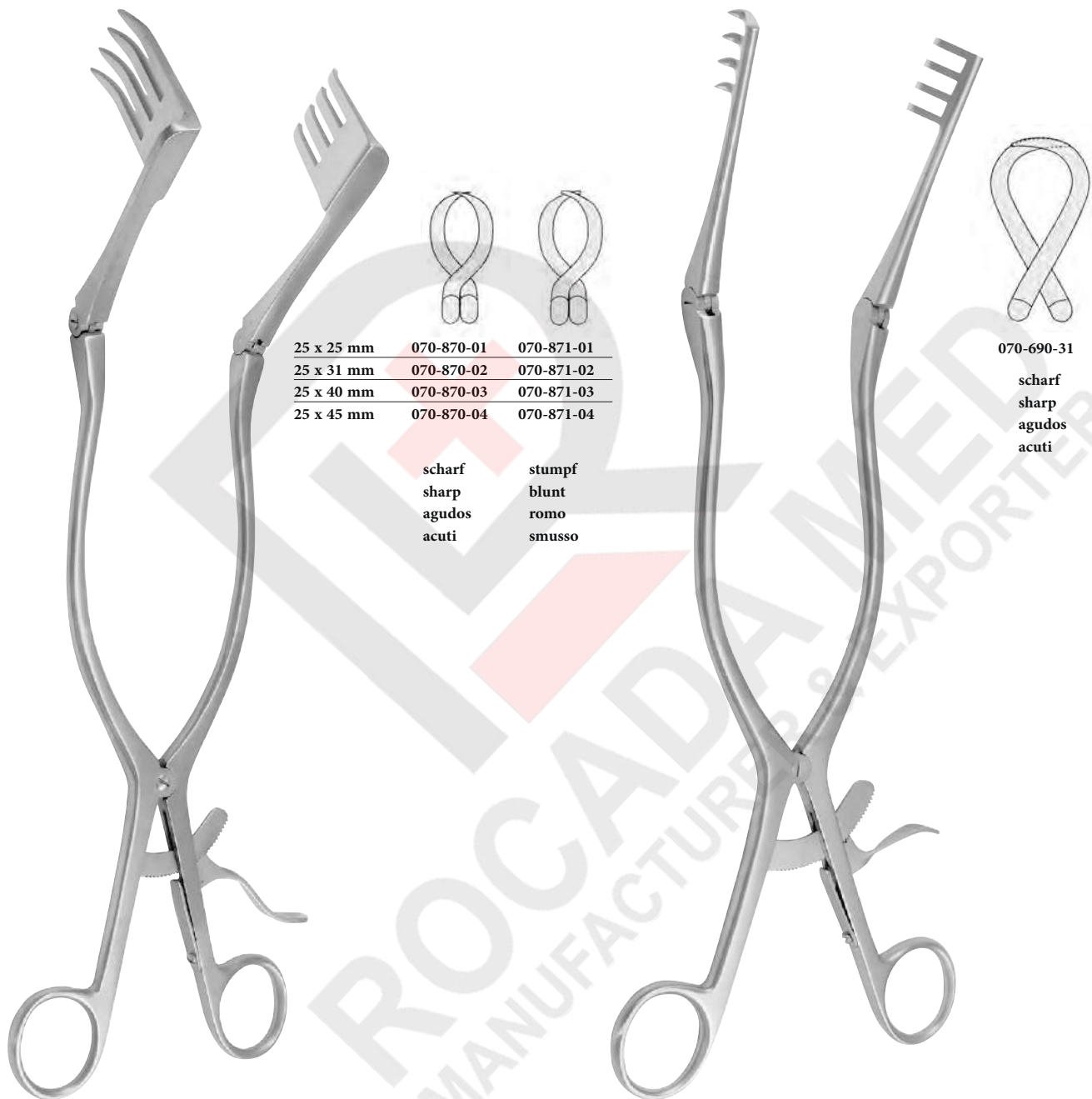

25 x 25 mm	070-870-01	070-871-01
25 x 31 mm	070-870-02	070-871-02
25 x 40 mm	070-870-03	070-871-03
25 x 45 mm	070-870-04	070-871-04

scharf	stumpf
sharp	blunt
agudos	romo
acuti	smusso



070-690-31

scharf
sharp
agudos
acuti

BECKMANN-ADSON
31,0 cm, 12 / 1/4 4

BECKMANN
31,0 cm, 12 / 1/4 4

070-690-31



070-691-32

stumpf
blunt
romo
smusso

BECKMANN
32,0 cm, 12 / $\frac{1}{2}$ 2



DE BAKKEY
10,0 cm, 4" 070-240-10
14,0 cm, 5 $\frac{1}{2}$ " 070-240-14

SURGICAL INSTRUMENTS



NORFOLK AND NORWICH
22,0 cm, 8 / $\frac{3}{4}$ 8
070-401-22



stumpf
blunt
romo
smusso



JACKSON BURROWS
17,5 cm, 7"
070-411-17



stumpf
blunt
romo
smusso



RICHTER
17,0 cm, 6 / $\frac{3}{4}$ 4
070-420-17



JOLL (FRIEDMAN)
15,5 cm, 6"
070-430-15

SURGICAL INSTRUMENTS

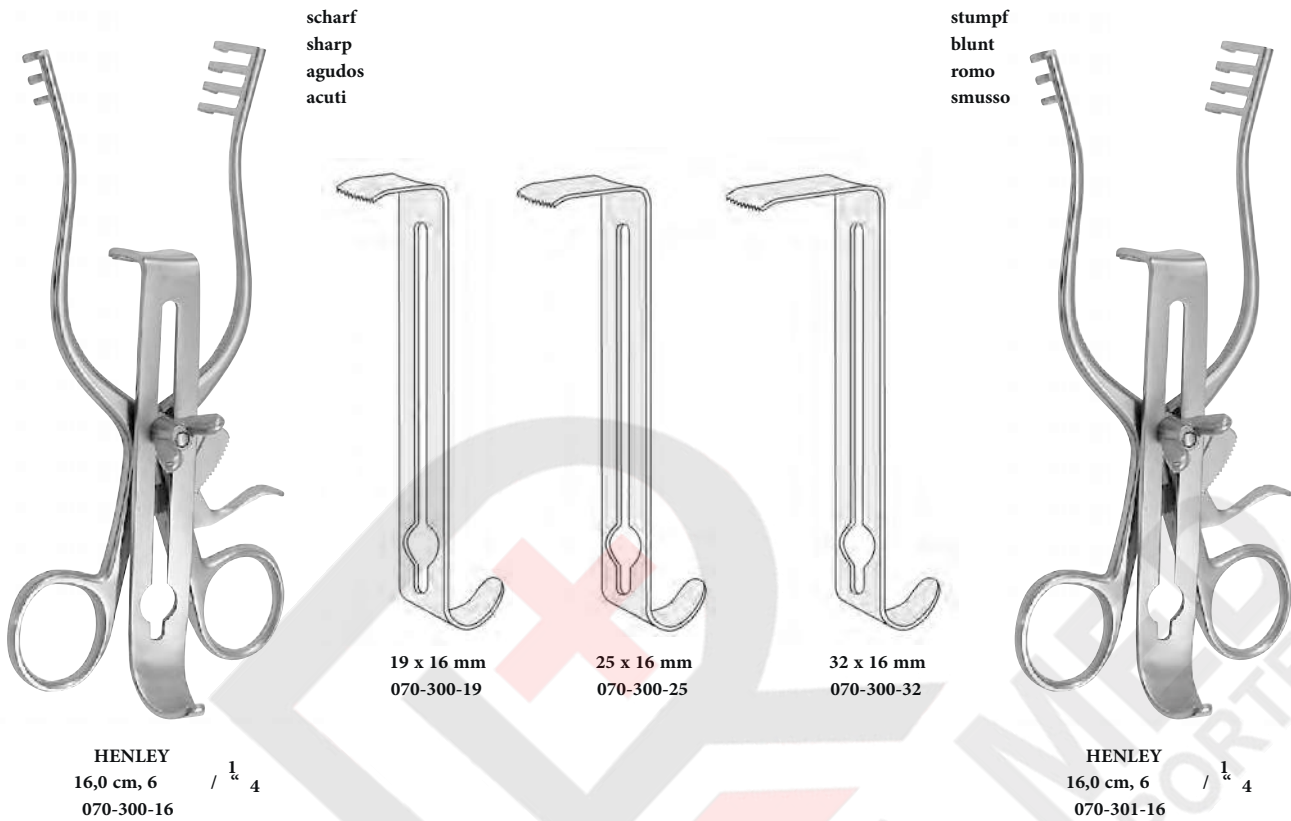

scharf
sharp
agudos
acuti

stumpf
blunt
romo
smusso

HENLEY
16,0 cm, 6 / $\frac{1}{4}$
070-300-16

HENLEY
16,0 cm, 6 / $\frac{1}{4}$
070-301-16

HENLEY
070-300-00

komplett, bestehend aus:

- 1 Sperrer mit Seitenventilen, scharf (30-1300-16)
- 1 Mittelvalve 19 x 16 mm (30-1300-19)
- 1 Mittelvalve 25 x 16 mm (30-1300-25)
- 1 Mittelvalve 32 x 16 mm (30-1300-32)

complete, consisting of:

- 1 Spreader with lateral valves, sharp (30-1300-16)
- 1 Central valve 19 x 16 mm (30-1300-19)
- 1 Central valve 25 x 16 mm (30-1300-25)
- 1 Central valve 32 x 16 mm (30-1300-32)

completo, compuesto of:

- 1 Separadorcon valvas laterales, agudas (30-1300-16)
- 1 Valva central 19 x 16 mm (30-1300-19)
- 1 Valva central 25 x 16 mm (30-1300-25)
- 1 Valva central 32 x 16 mm (30-1300-32)

completo, composto da:

- 1 Divaricatore con valve laterali, acuto (30-1300-16)
- 1 Valva centrale 19 x 16 mm (30-1300-19)
- 1 Valva centrale 25 x 16 mm (30-1300-25)
- 1 Valva centrale 32 x 16 mm (30-1300-32)

HENLEY
070-301-00

komplett, bestehend aus:

- 1 Sperrer mit Seitenventilen, stumpf (30-1301-16)
- 1 Mittelvalve 19 x 16 mm (30-1300-19)
- 1 Mittelvalve 25 x 16 mm (30-1300-25)
- 1 Mittelvalve 32 x 16 mm (30-1300-32)

complete, consisting of:

- 1 Spreader with lateral valves, blunt (30-1301-16)
- 1 Central valve 19 x 16 mm (30-1300-19)
- 1 Central valve 25 x 16 mm (30-1300-25)
- 1 Central valve 32 x 16 mm (30-1300-32)

completo, compuesto of:

- 1 Separadorcon valvas laterales, romas (30-1301-16)
- 1 Valva central 19 x 16 mm (30-1300-19)
- 1 Valva central 25 x 16 mm (30-1300-25)
- 1 Valva central 32 x 16 mm (30-1300-32)

completo, composto da:

- 1 Divaricatore con valve laterali, smusso (30-1301-16)
- 1 Valva centrale 19 x 16 mm (30-1300-19)
- 1 Valva centrale 25 x 16 mm (30-1300-25)
- 1 Valva centrale 32 x 16 mm (30-1300-32)

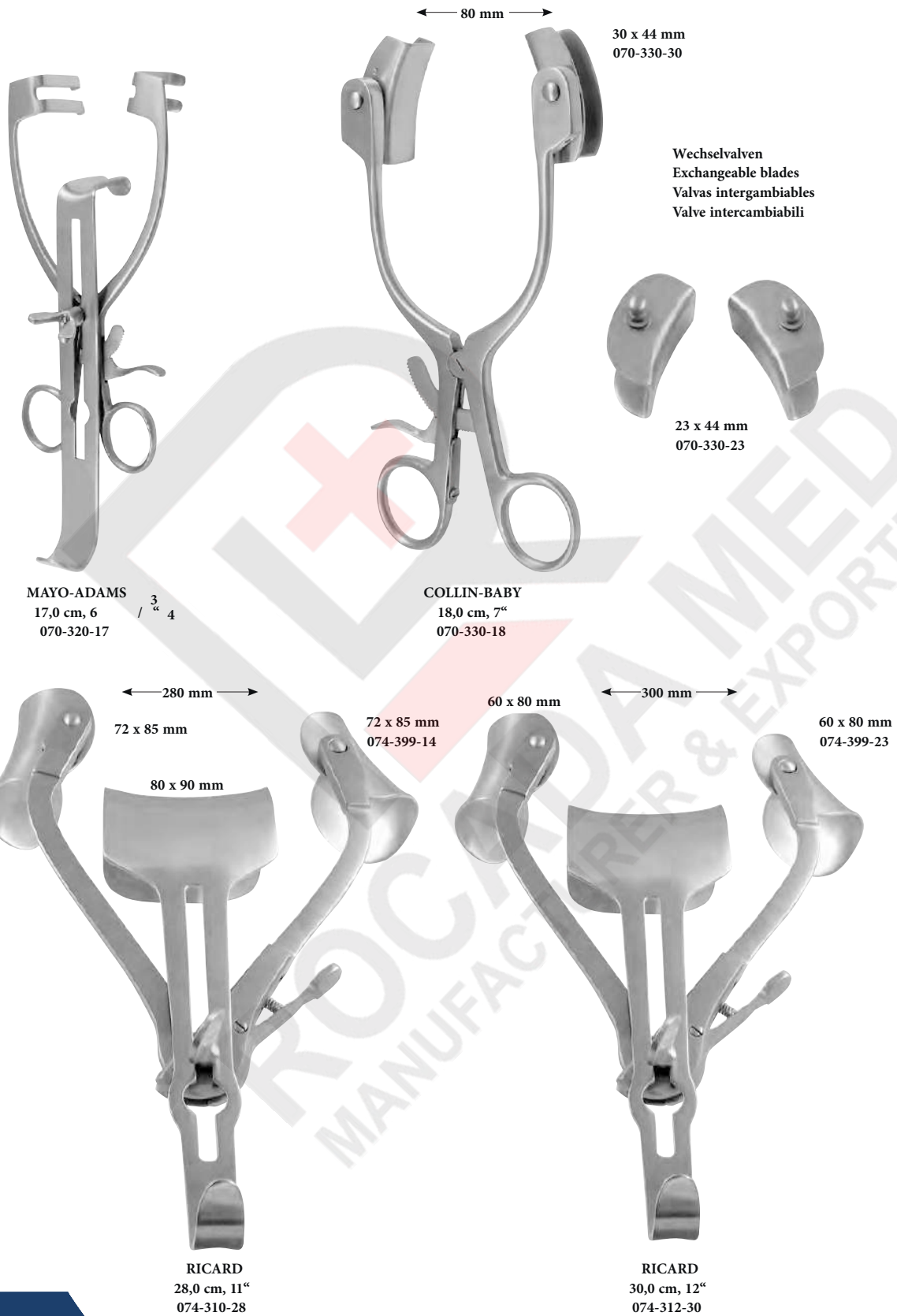

38 x 62 mm
074-398-10

← 135-160 mm →



38 x 62 mm

55 x 55 mm

COLLIN
23,5 cm, 9 / 1/4"
074-330-24

40 x 80 mm

← 135-160 mm →



40 x 80 mm
074-398-11

55 x 65 mm

COLLIN
23,5 cm, 9 / 1/4"
074-332-24

60 x 80 mm
074-398-13

← 135-160 mm →



60 x 80 mm

60 x 75 mm

COLLIN
23,5 cm, 9 / 1/4"
074-334-24

SURGICAL INSTRUMENTS



38 x 62 mm	074-399-01
40 x 80 mm	074-399-02
60 x 80 mm	074-399-03



50 x 58 mm	074-399-10
60 x 80 mm	074-399-13
72 x 85 mm	074-399-14



074-399-23
60 x 80 mm

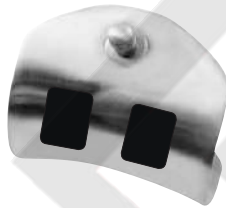

074-399-33
60 x 80 mm



58 x 50 mm	074-398-01
80 x 60 mm	074-398-02
85 x 72 mm	074-398-03



1 62 x 38 mm	074-398-10
1 80 x 38 mm	074-398-11
100 x 38 mm	074-398-12
1 80 x 38 mm	074-398-13



COLLIN	
55 x 55 mm	074-331-01
55 x 65 mm	074-331-02
55 x 75 mm	074-331-03



RICARD	
65 x 50 mm	074-310-01
70 x 55 mm	074-310-02
90 x 80 mm	074-310-03

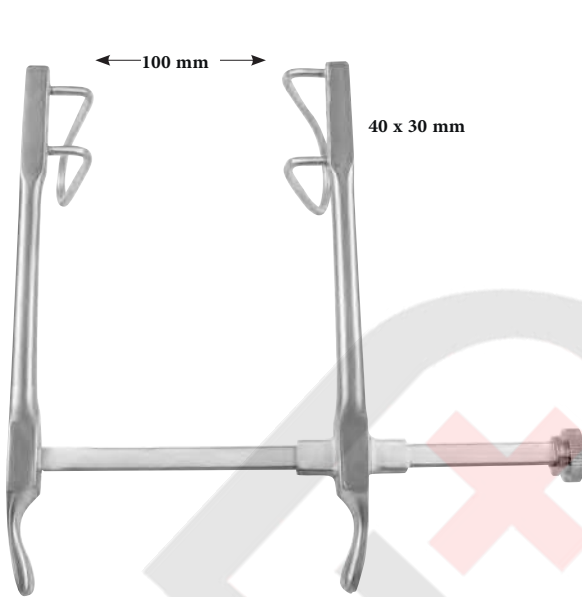

GOSSET
074-400-10

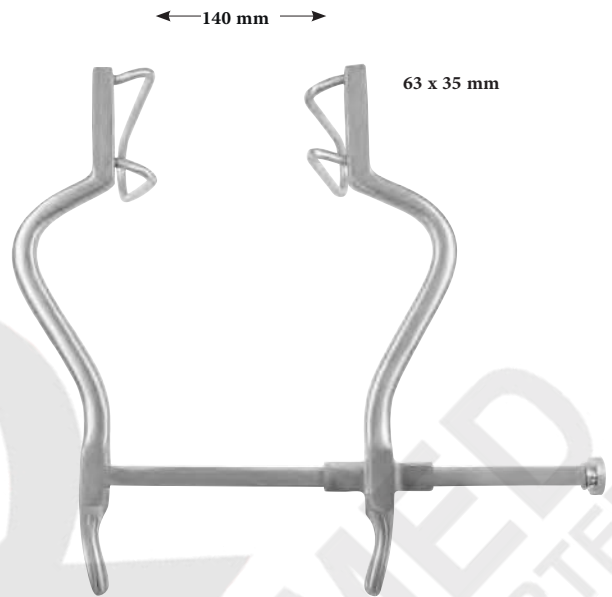

GOSSET
074-412-14

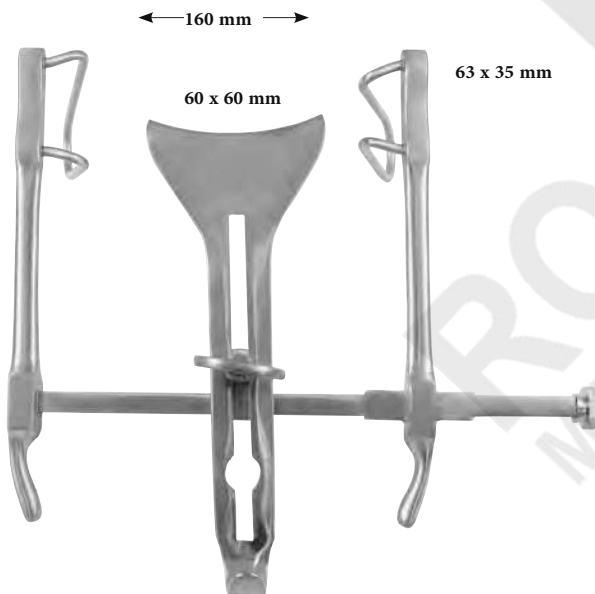

GOSSET
074-414-16



ABADIE
074-450-12

SURGICAL INSTRUMENTS

SURGICAL INSTRUMENTS

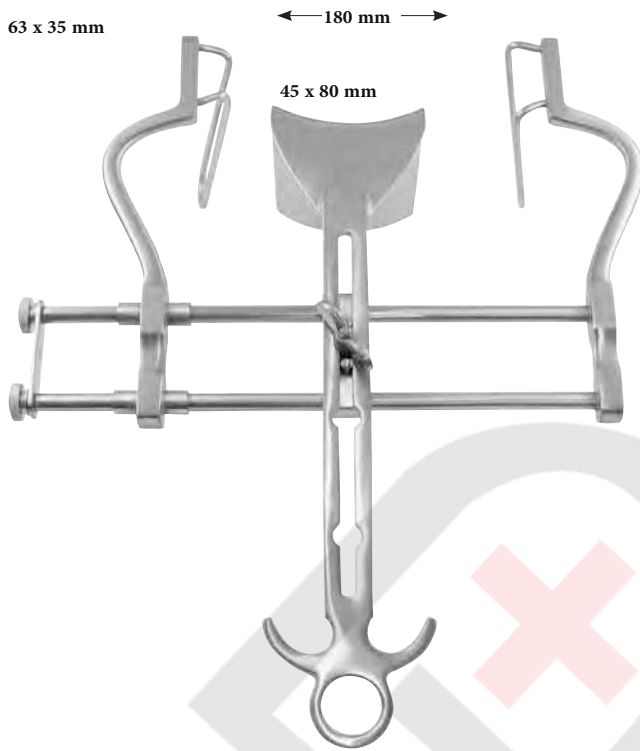

BALFOUR
074-764-18

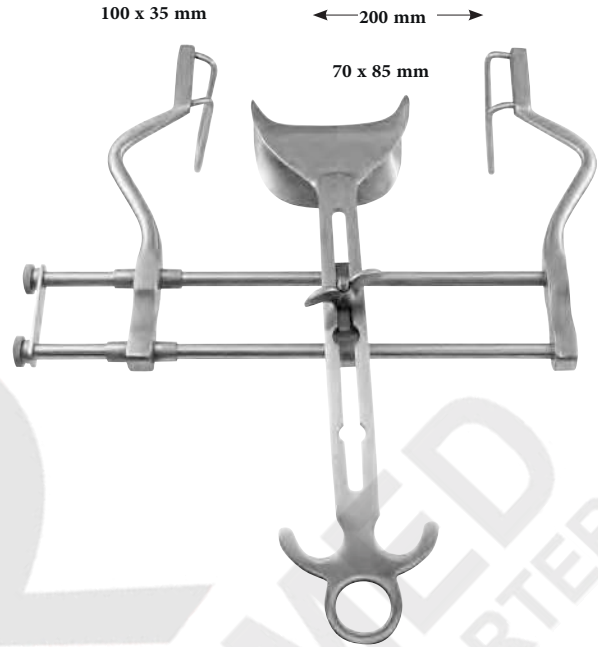

BALFOUR
074-768-20

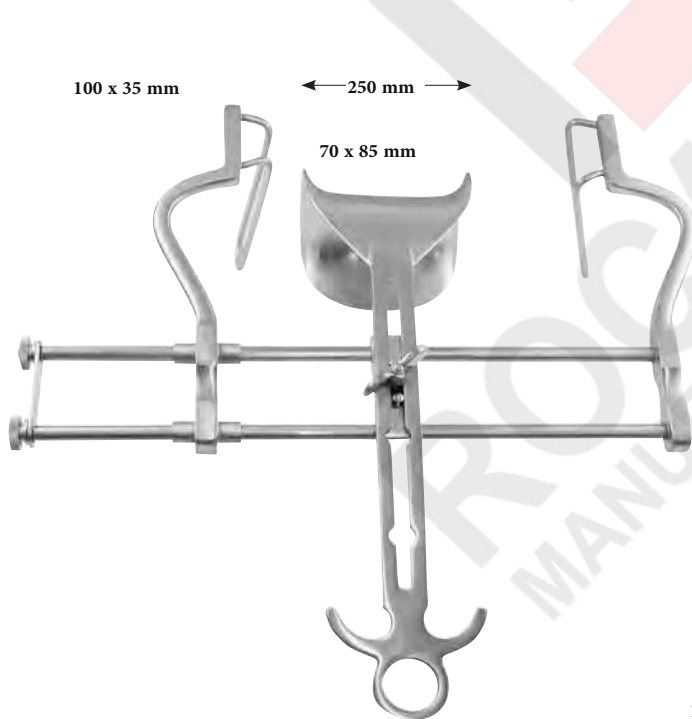

BALFOUR
074-768-25

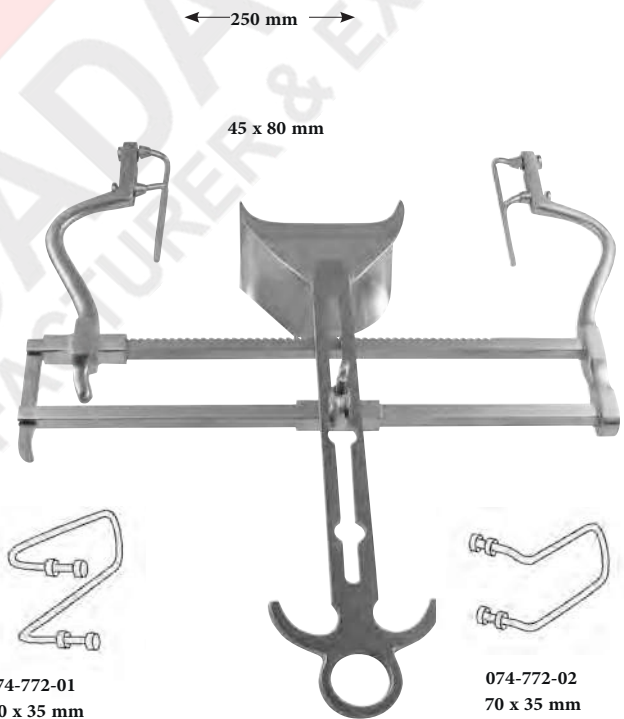

BALFOUR US-TYPE
074-772-25

074-772-01
100 x 35 mm

074-772-02
70 x 35 mm

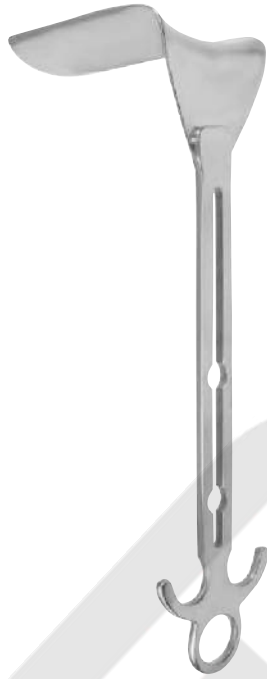

BALFOUR
 100 x 70 mm
 074-799-70

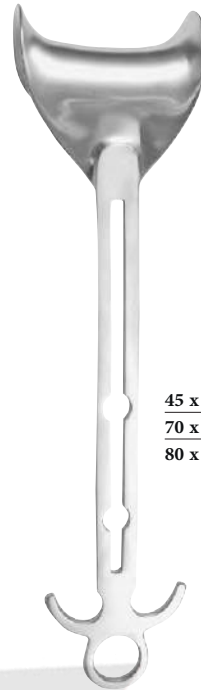

BALFOUR

45 x 80 mm	074-798-01
70 x 85 mm	074-798-02
80 x 90 mm	074-798-03

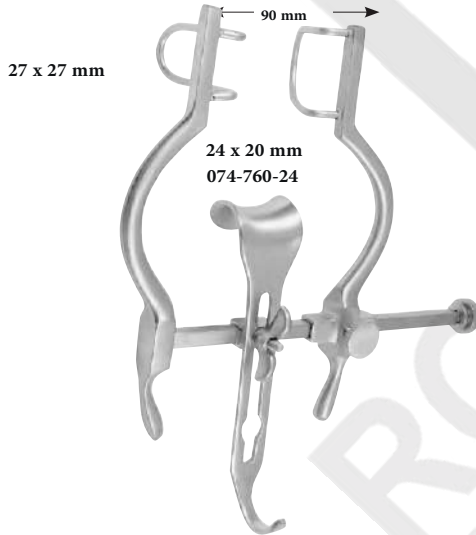

BALFOUR
 074-760-09

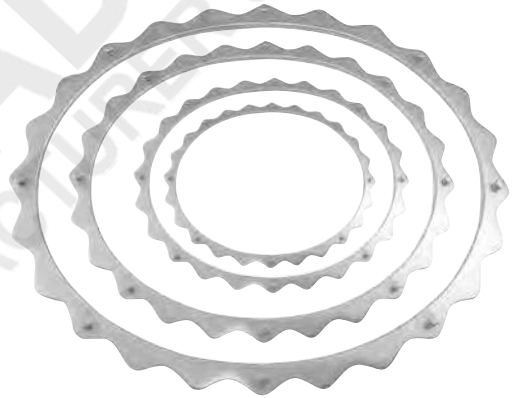

Ø 180 mm, 7"	074-850-18
Ø 230 mm, 9"	074-850-23
Ø 305 mm, 12"	074-850-30
455 x 330 mm	074-850-45

SURGICAL INSTRUMENTS

geschwärzt, black finish, negra, nera;



074-859-02
51 x 38 mm



074-859-03
70 x 60 mm



074-859-05
114 x 60 mm

geschwärzt, black finish, negra, nera



074-859-06
19 x 76 mm



074-859-07
38 x 102 mm



074-859-08
57 x 89 mm



074-859-09
57 x 114 mm

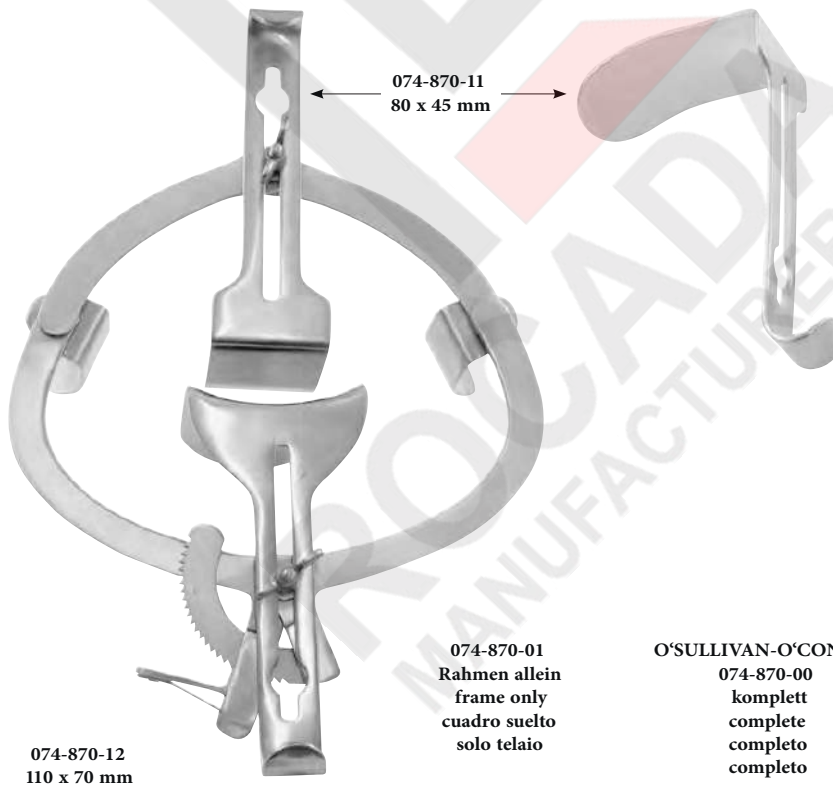
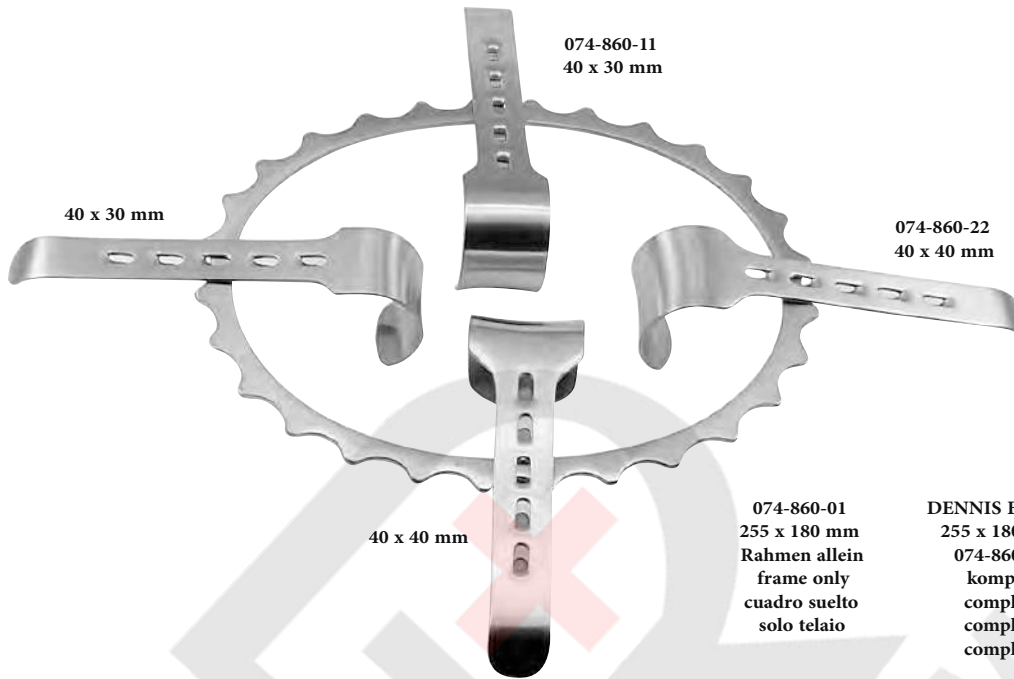

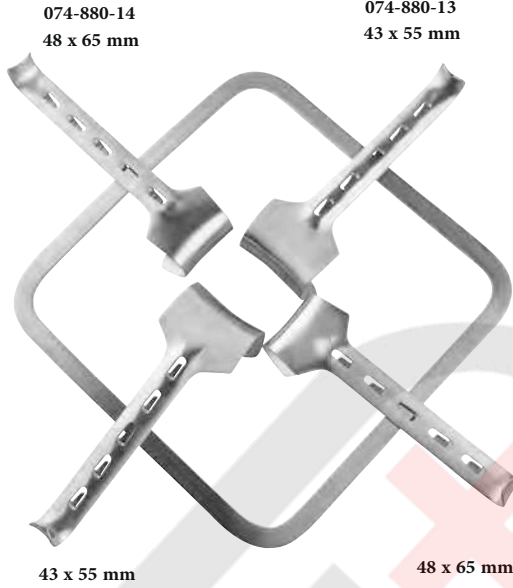

074-880-14
48 x 65 mm

074-880-13
43 x 55 mm

43 x 55 mm

48 x 65 mm

074-880-01 250 x 250 mm
074-880-02 300 x 320 mm
074-880-03 300 x 380 mm

Rahmen allein
frame only
cuadro suelto
solo telaio

KIRSCHNER

074-880-00
komplett
complete
completo
completo
1 x 31-1880-01
2 x 31-1880-13
2 x 31-1880-14

074-882-01
255 x 255 mm
zusammenlegbarer Rahmen, allein
folding frame, only
cuadro plegable, suelto
telaio pieghevole, solo



KIRSCHNER
074-882-00
komplett
complete
completo
completo
1 x 31-1882-01
2 x 31-1882-13
2 x 31-1882-14



43 x 55 mm	074-880-13
48 x 65 mm	074-880-14
80 x 90 mm	074-880-15
90 x 65 mm	074-880-16
98 x 95 mm	074-880-17

KIRSCHNER



KIRSCHNER
60 x 82 mm
074-880-11



KIRSCHNER-BALFOUR
83 x 82 mm
074-880-12



KIRSCHNER
198 x 51 mm 074-880-20
105 x 38 mm 074-880-21

074-880-14
48 x 65 mm

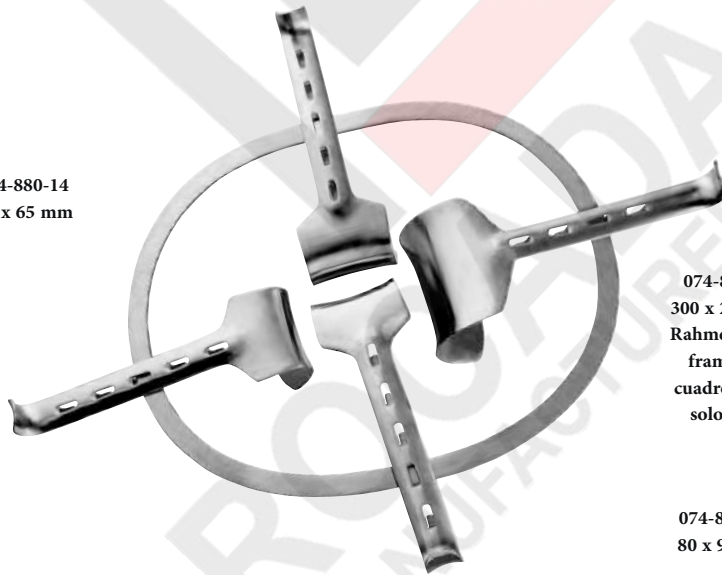

KIRSCHNER, oval
074-884-00
komplett, complete, completo, comple to
1 x 31-1884-01
3 x 31-1884-14
1 x 31-1884-15
1 x 31-1884-20
1 x 31-1884-21

074-890-00
300 x 240 mm
Rahmen allein
frame only
cuadro suelto
solo telaio

074-880-15
80 x 90 mm

SURGICAL INSTRUMENTS

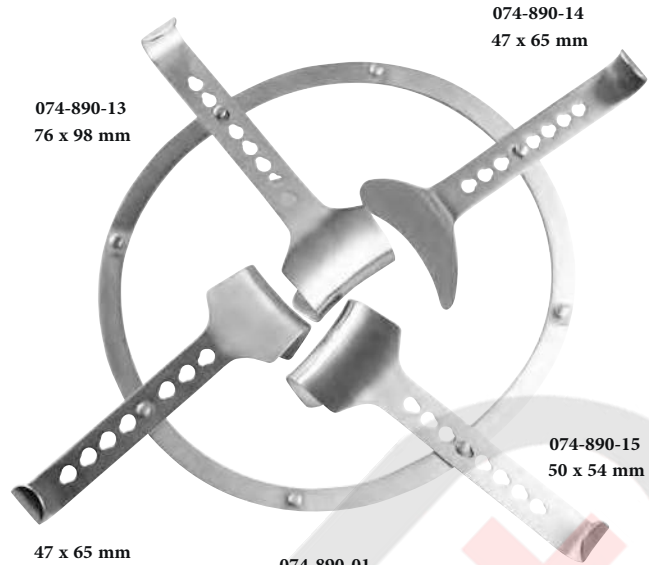

074-890-01
275 x 250 mm
Rahmen allein
frame only
cuadro suelto
solo telaio

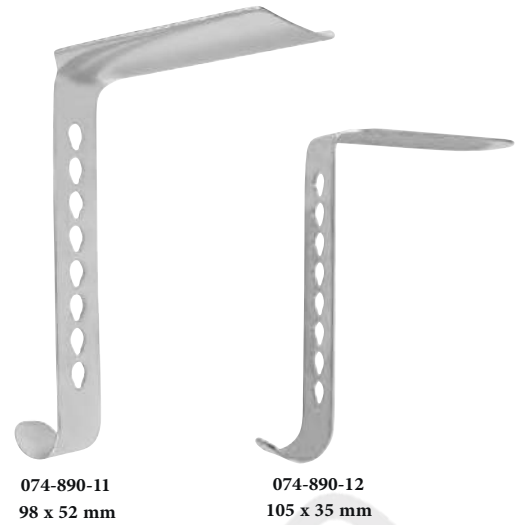

074-900-01
300 x 300 mm
zusammenlegbarer Rahmen, allein
folding frame, only
cuadro piegabile, suelto
telaio pieghevole, solo

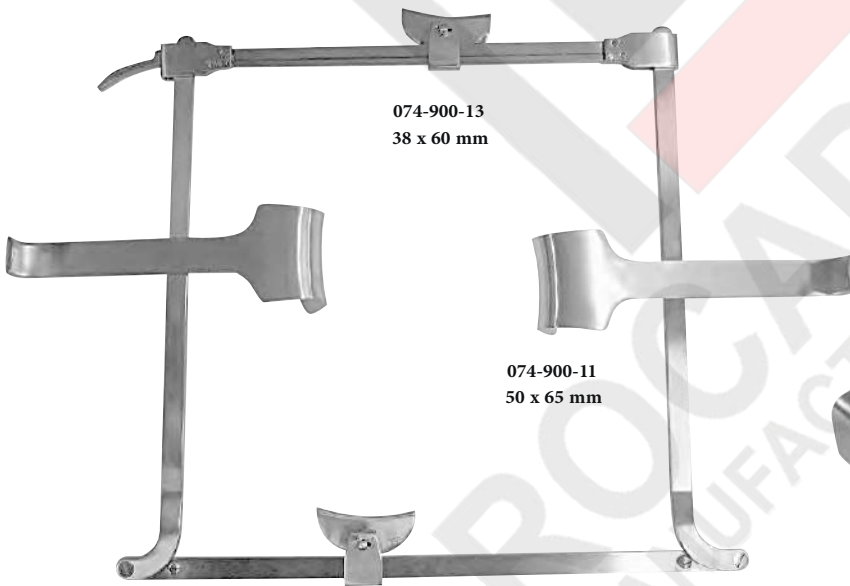

FRANZ
074-900-00
komplett
complete
completo
completo
1 x 31-1900-01

38 x 60 mm 074-900-13
45 x 80 mm 074-900-14

50 x 65 mm 074-900-11
60 x 85 mm 074-900-12

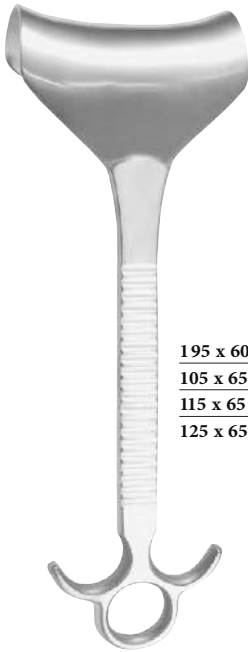

DOYEN
28,0 cm, 11"

195 x 60 mm	074-910-11
105 x 65 mm	074-910-12
115 x 65 mm	074-910-13
125 x 65 mm	074-910-14

für / for / para / per
074-910-11
074-910-14

Kette mit Gewicht
Chain with weight
Cadena con pesa
Catena con peso



074-915-30
78,5 cm, 31"

53,0 cm, 21"

66,0 cm, 26"

Befestigungsgestell
Mounting frame
Bastidor para la fijación
Telaio di supporto per il fissaggio

ROCHARD
074-920-01



ROCHARD
28,0 cm, 11"
074-920-20

195 x 48 mm	074-920-10
105 x 48 mm	074-920-12
115 x 48 mm	074-920-12
125 x 48 mm	074-920-13
155 x 48 mm	074-920-16

53,0 cm, 21"

66,0 cm, 26"

Befestigungsgestell
Mounting frame
Bastidor para la fijación
Telaio di supporto per il fissaggio

ROCHARD
074-920-02

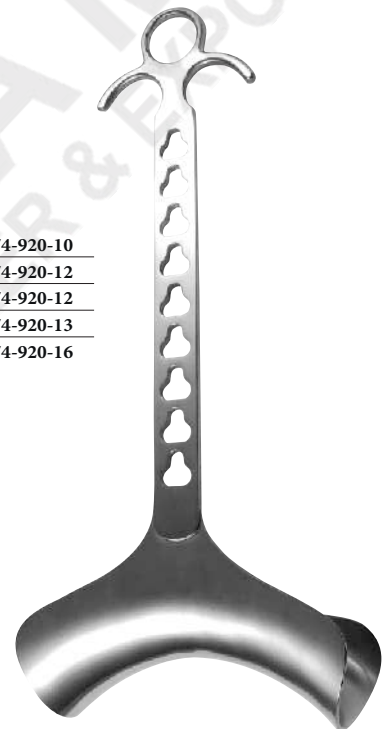

ROCHARD
28,0 cm, 11"

SURGICAL INSTRUMENTS

SURGICAL INSTRUMENTS



biegsam
malleable
maleable
malleabile

200 x 6 mm 078-210-06
200 x 12 mm 078-210-12
200 x 17 mm 078-210-17
200 x 20 mm 078-210-20
200 x 25 mm 078-210-25

RIBBON



biegsam
malleable
maleable
malleabile

330 x 13 mm 078-170-13
330 x 25 mm 078-170-25
330 x 32 mm 078-170-32
330 x 40 mm 078-170-40
330 x 50 mm 078-170-50

RIBBON



biegsam
malleable
maleable
malleabile

280 x 25/30 mm 078-200-01
300 x 37/45 mm 078-200-02
300 x 40/50 mm 078-200-03

RIBBON



biegsam
malleable
maleable
malleabile

TUFFIER
200 x 25/17 mm
078-220-20



REVERDIN
280 x 45/60 mm
078-230-28

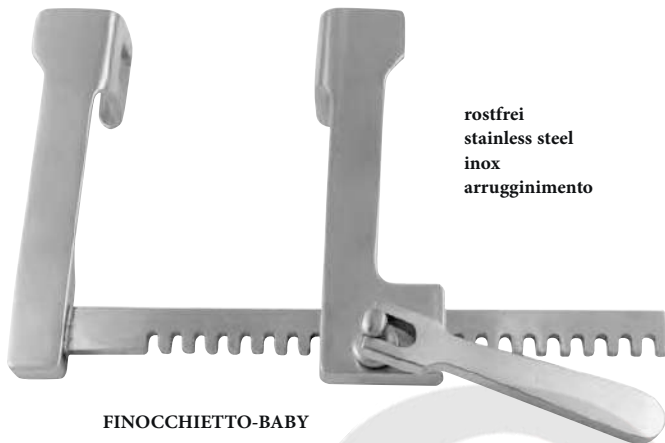

rostfrei
stainless steel
inox
arrugginimento

FINOCCHIETTO-BABY

a	b	c	
18 mm	20 mm	75 mm	140-100-01

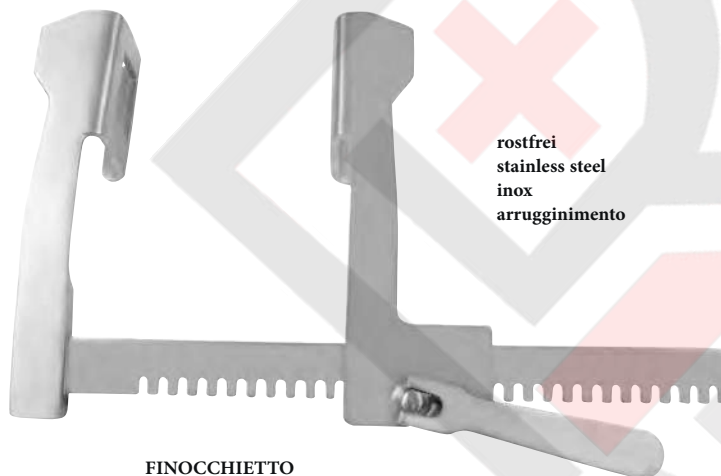

rostfrei
stainless steel
inox
arrugginimento

FINOCCHIETTO

a	b	c	
40 mm	40 mm	165 mm	140-100-02
45 mm	65 mm	200 mm	140-100-03
70 mm	65 mm	250 mm	140-100-04



rostfrei
stainless steel
inox
arrugginimento

TUFFIER

a	b	c	
50 mm	45 mm	165 mm	140-150-01

SURGICAL INSTRUMENTS



	Ø 1,0 mm	Ø 2,0 mm
11,5 cm, 4 1/2"	080-000-11	080-004-11
13,0 cm, 5"	080-000-13	080-004-13
14,5 cm, 5 3/4"	080-000-14	080-004-14
16,0 cm, 6 1/4"	080-000-16	080-004-15
18,0 cm, 7"	080-000-18	080-004-18
20,0 cm, 8"	080-000-20	080-004-20

Ø 2,0 mm



Ø 1,0 mm



Silber
Silver
Plata
Argento

11,5 cm, 4 1/2"	080-013-11
13,0 cm, 5"	080-013-13
14,5 cm, 5 3/4"	080-013-14
16,0 cm, 6 1/4"	080-013-16
18,0 cm, 7"	080-013-18
20,0 cm, 8"	080-013-20

STACKE
10,5 cm, 4 / 1/4 8
080-033-10

Myrtenblattsonden
Myrtle leaf probes
Sondas para mirto
Sonde a foglia di mirto

11,5 cm, 4 1/2"	080-027-11
13,0 cm, 5"	080-027-13
14,5 cm, 5 3/4"	080-027-14
16,0 cm, 6 1/4"	080-027-16
18,0 cm, 7"	080-027-18
20,0 cm, 8"	080-027-20



NÉLATON
16,0 cm, 6 / 1/4 4
080-120-16



DOYEN
14,5 cm, 5 / 3/4 4
080-117-14



Ø 3,5 mm
BRODIE
20,0 cm, 8"
080-126-20

Ø 3,5 mm



11,5 cm, 4	1/2"	080-110-11
13,0 cm, 5"		080-110-13
14,5 cm, 5	3/4"	080-110-14
16,0 cm, 6	1/4"	080-110-16
18,0 cm, 7"		080-110-18
20,0 cm, 8"		080-110-20

Ø 3,3 mm



13,0 cm, 5"		080-122-13
14,5 cm, 5	3/4"	080-122-14
16,0 cm, 6	1/4"	080-122-16
18,0 cm, 7"		080-122-18



LOCKHART-MUMMERY
16,5 cm, 6 / 2
080-130-01

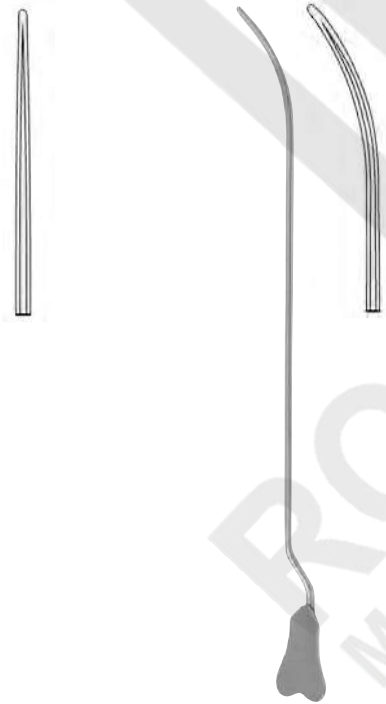

LOCKHART-MUMMERY
16,5 cm, 6 / 2
080-130-02



LOCKHART-MUMMERY
16,5 cm, 6 / 2
080-130-03

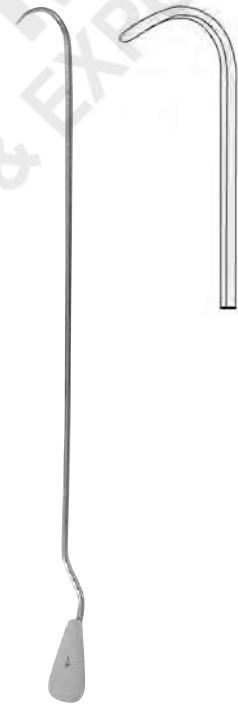

LOCKHART-MUMMERY
16,5 cm, 6 / 2
080-130-04

SURGICAL INSTRUMENTS

SURGICAL INSTRUMENTS

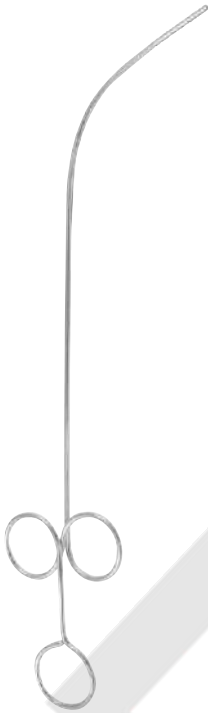

FEIN
28,0 cm, 11"
080-264-28



UKERMANN
16,0 cm, 6" / 1/4"
080-260-16



JOBSON-HORNE
18,0 cm, 7"
080-262-18



FARRELL
(LATHBURY)

12,0 cm, 4"	3/4"	080-271-12	Ø 0,9 mm
14,0 cm, 5"	3/4"	080-271-14	Ø 0,9 mm
16,5 cm, 6"	1/2"	080-271-16	Ø 1,1 mm
18,0 cm, 7"		080-271-18	Ø 1,2 mm



FARRELL

12,0 cm, 4"	3/4"	080-270-12	Ø 0,9 mm
14,0 cm, 5"	3/4"	080-270-14	Ø 0,9 mm
16,5 cm, 6"	1/2"	080-270-16	Ø 1,1 mm
18,0 cm, 7"		080-270-18	Ø 1,2 mm



080-150-01
Metalletui
Metal case
Estuche de metal
Scatola in metallo

135 x 100 x 25 mm



Ø 3,0 mm
080-150-03



Ø 6,0 mm
080-150-06



Ø 9,0 mm
080-150-09



Ø 12,0 mm
080-150-12

NABATOFF
080-150-00
komplett
complete
completo
completo



080-150-21
Zugseil
Cable
Cable
Fune

080-150-22
Kunststoff-Sondenspitze
Plastic probe tip
Extremidad de sonda de plástico
Punta in materia plastica

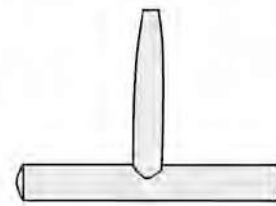

080-150-20
Handgriff
Handle
Mango
Manico

SURGICAL INSTRUMENTS



Ø 3,0 mm	084-110-30
Ø 3,5 mm	084-110-35
Ø 4,0 mm	084-110-40
Ø 4,5 mm	084-110-45
Ø 5,0 mm	084-110-50
Ø 5,5 mm	084-110-55
Ø 6,0 mm	084-110-60

STANDARD
11,0 cm, 4 / $\frac{3}{8}$



Ø 3,0 mm	084-112-30
Ø 3,5 mm	084-112-35
Ø 4,0 mm	084-112-40
Ø 4,5 mm	084-112-45
Ø 5,0 mm	084-112-50
Ø 5,5 mm	084-112-55
Ø 6,0 mm	084-112-60

STANDARD
12,0 cm, 4 / $\frac{3}{4}$



Ø 3,0 mm	084-114-30
Ø 3,5 mm	084-114-35
Ø 4,0 mm	084-114-40
Ø 4,5 mm	084-114-45
Ø 5,0 mm	084-114-50
Ø 5,5 mm	084-114-55
Ø 6,0 mm	084-114-60

STANDARD
12,0 cm, 4 / $\frac{3}{4}$



Ø 17,3 mm	084-118-07
Ø 18,7 mm	084-118-09
Ø 12,0 mm	084-118-12

HURWITZ

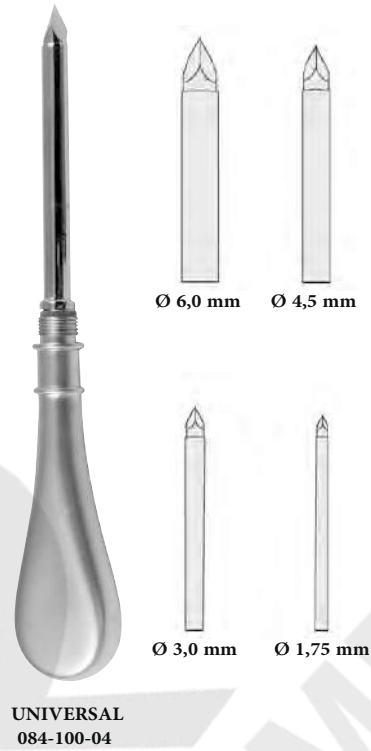
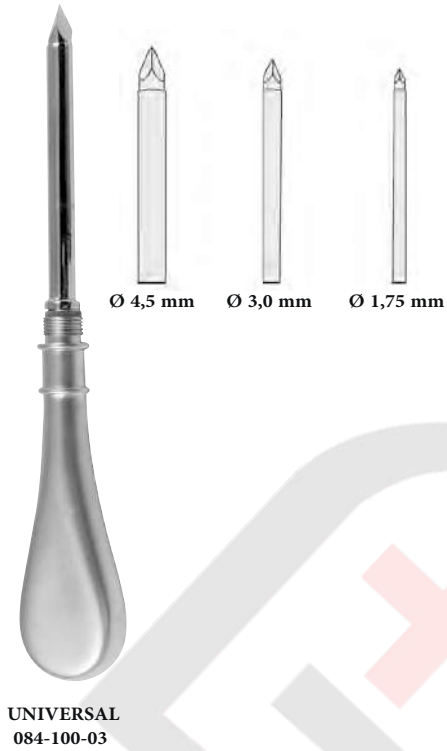

SURGICAL INSTRUMENTS

SURGICAL INSTRUMENTS

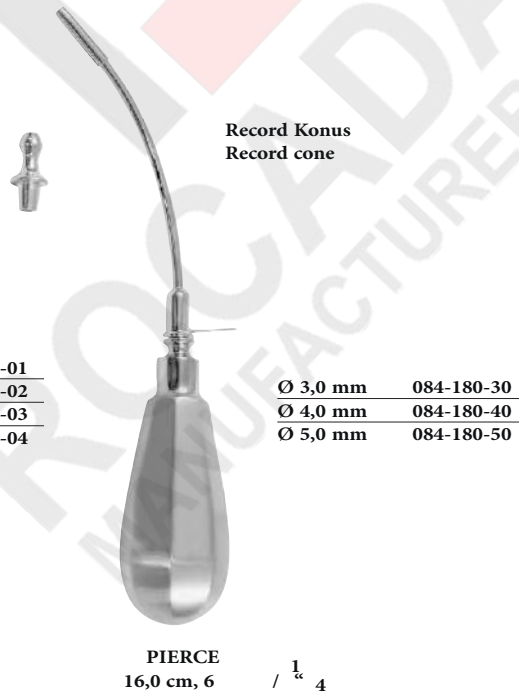
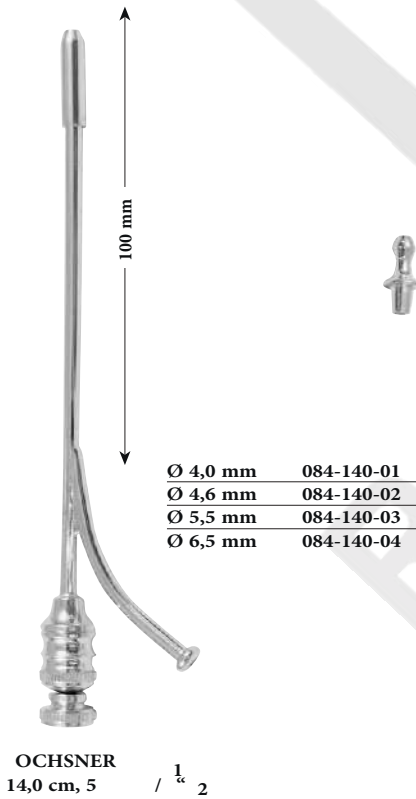
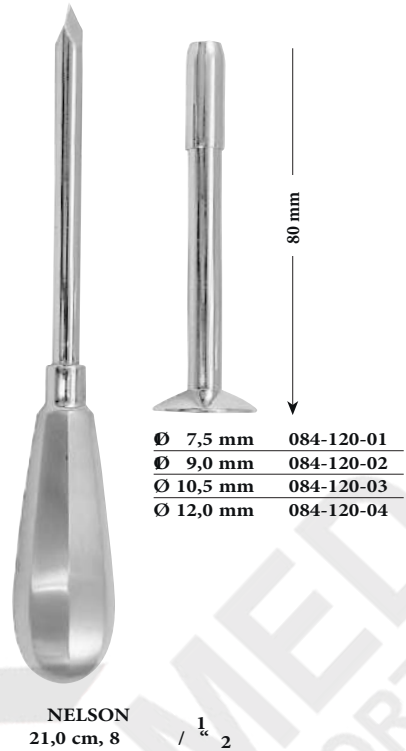
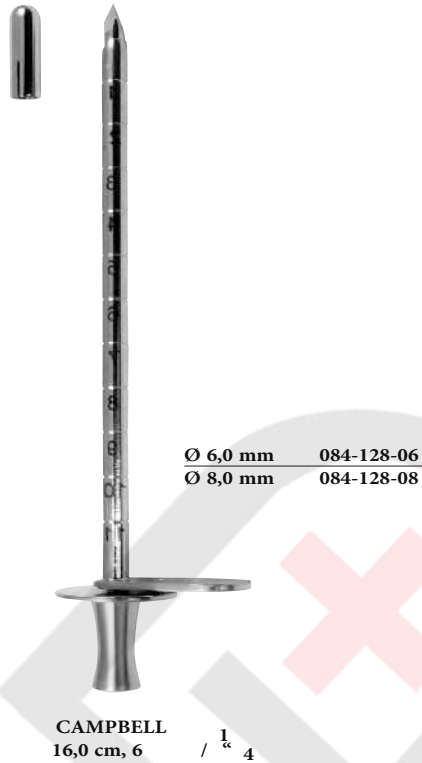

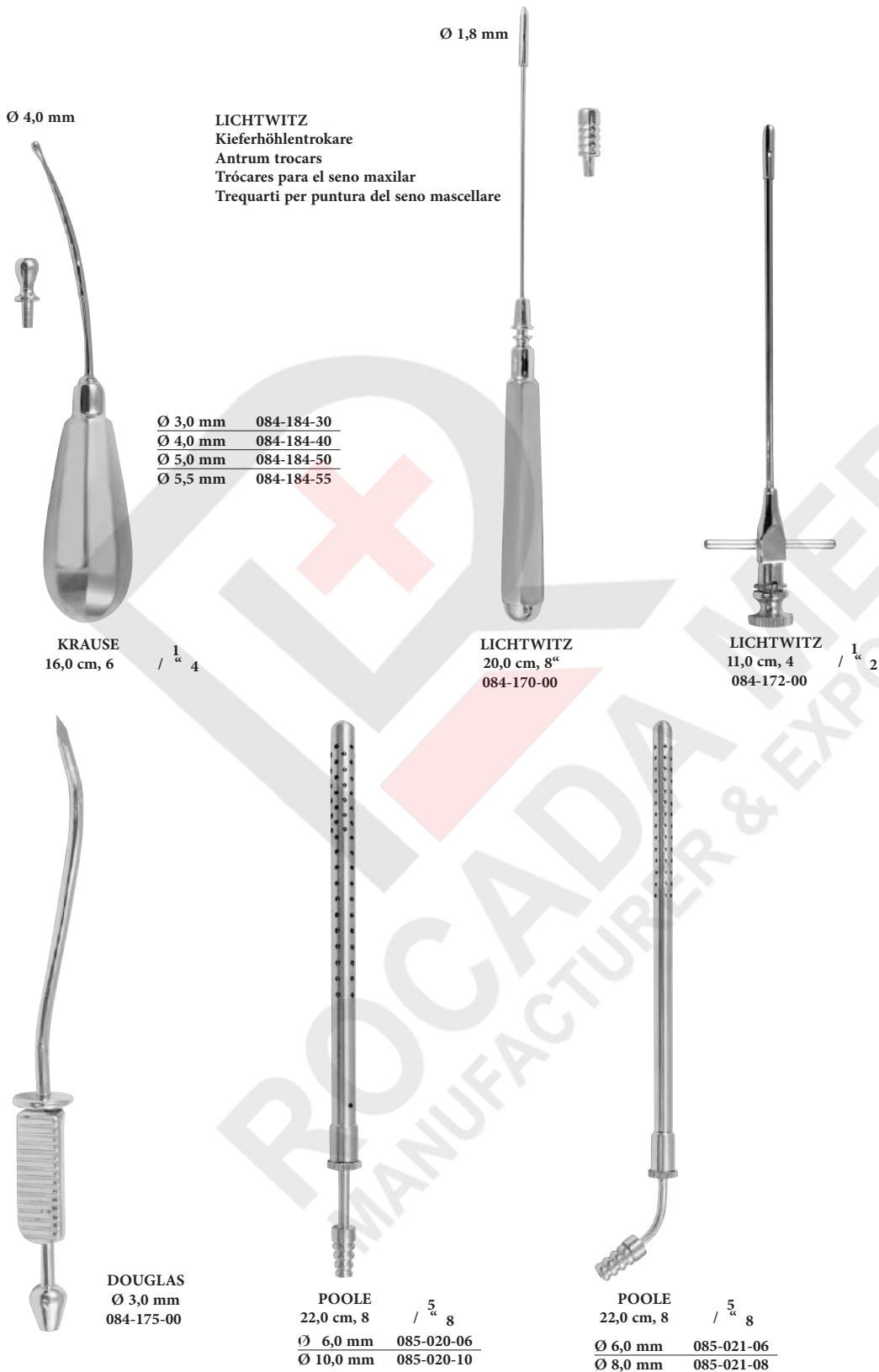

SURGICAL INSTRUMENTS

auswechselbare Spitze
interchangeable tip
punta intercambiables
tipo intercambiabile

Ø 3,5 mm
085-010-35

085-024-00
Olive allein
Olive only
Oliva suelto
Olivo solo



COUPLAND
17,0 cm, 6 / 3/4
085-010-17



YANKAUER
27,0 cm, 10 / 5/8
085-000-27



DE BAKERY
27,0 cm, 10 / 5/8
085-008-27



ANTHONY
826,0 cm, 10
085-007-26



ANDREWS-PYNCHON
24,0 cm, 9 / 3/4
085-006-24



COOLEY
35,0 cm, 13 / 3/4
Ø 8,0 mm
085-024-02



COOLEY
30,0 cm, 11 / 3/4
Ø 7,0 mm
085-024-03



COOLEY
31,0 cm, 11 / 3/4
Ø 10,0 mm
085-024-04



COOLEY
33,0 cm, 13"
Ø 8,0 mm
085-024-01

SURGICAL INSTRUMENTS



BYRD
20,0 cm, 8"
Ø 1,5 mm 085-012-15
Ø 2,5 mm 085-012-25
Ø 3,5 mm 085-012-35

Ø 4,0 mm



ADSON
21,0 cm, 8" / 1/4"
085-050-21



MAGILL
17,5 cm, 6" / 5/8"
Ø 1,0 mm 085-060-01
Ø 2,0 mm 085-060-02
Ø 3,0 mm 085-060-03
Ø 4,0 mm 085-060-04



FRAZIER
19,0 cm, 7" / 1/2"



FERGUSON
18,0 cm, 7"

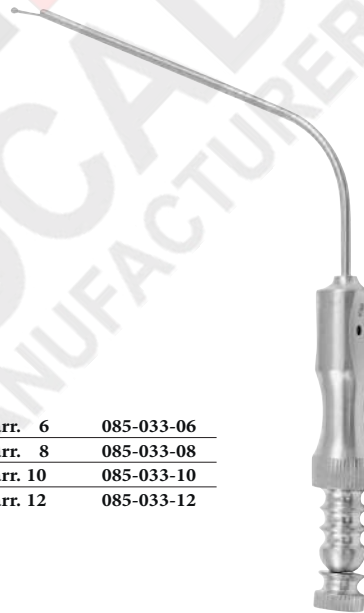

POPPEN
13,0 cm, 5"

Charr. 6 085-030-06
Charr. 8 085-030-08
Charr. 10 085-030-10
Charr. 12 085-030-12

Charr. 6 085-033-06
Charr. 8 085-033-08
Charr. 10 085-033-10
Charr. 12 085-033-12

Charr. 6 085-034-06
Charr. 8 085-034-08
Charr. 10 085-034-10
Charr. 12 085-034-12

SURGICAL INSTRUMENTS

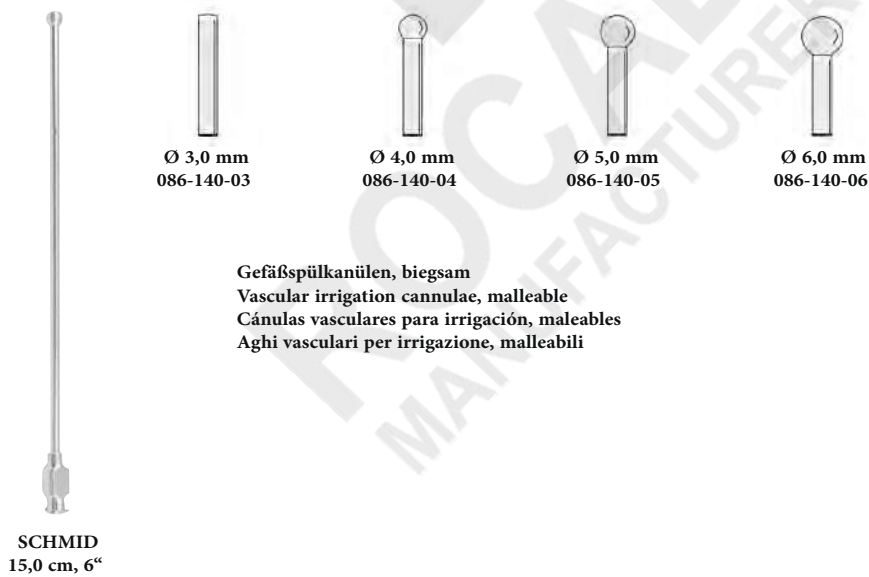
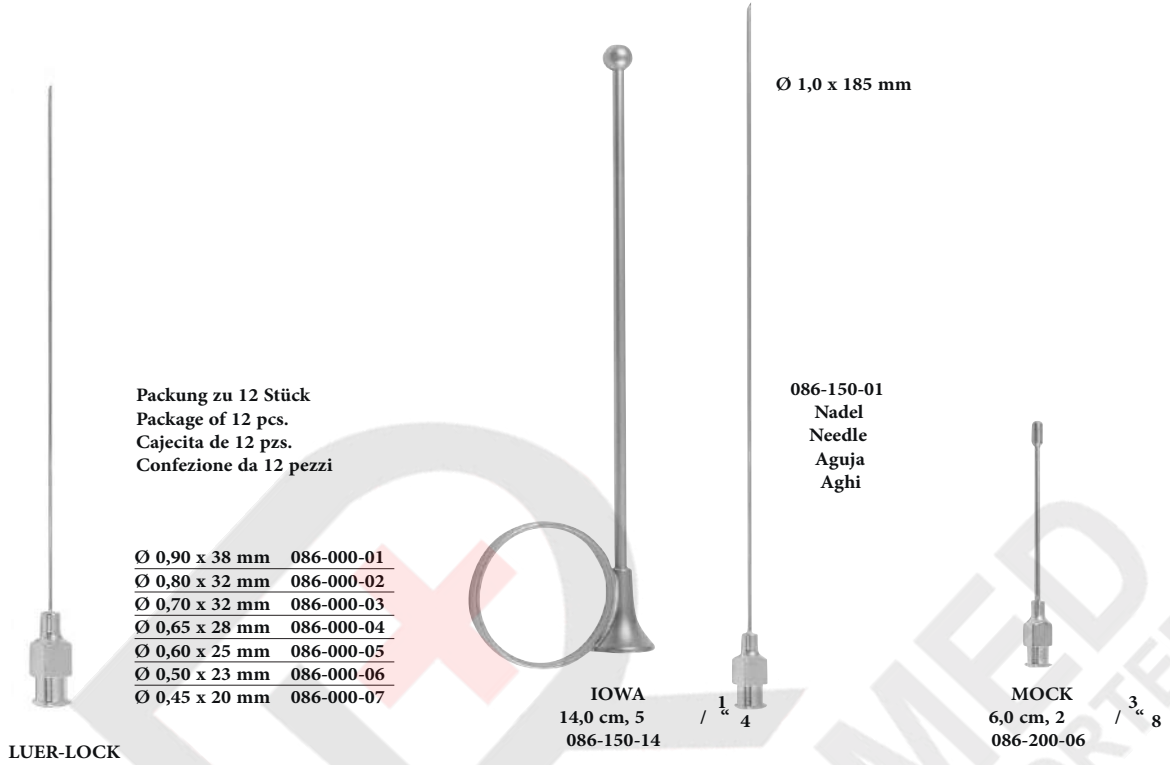



Ø 1,20 x 80 mm 086-210-12
Ø 1,50 x 80 mm 086-210-15



VERESS

Ø 2,00 x 100 mm 086-180-10
Ø 2,00 x 120 mm 086-180-12
Ø 2,00 x 150 mm 086-180-15

Kanülen zur Sternalpunktion
Sternum puncture needles
Agujas para la punción del esternón
Aghi per puntura dello sterno



KLIMA-ROSSEGGER
Ø 1,60 x 40 mm
086-060-16

Kanülen zur Lumbalpunktion
Lumbar puncture needles
Agujas para punción lumbar
Aghi per punture lombari



BIER

Ø 0,8 x 70/80/90/100/120 mm 086-130-01
Ø 1,0 x 70/80/90/100/120 mm 086-130-02
Ø 1,2 x 70/80/90/100/120 mm 086-130-03
Ø 1,4 x 70/80/90/100/120 mm 086-130-04
Ø 1,6 x 70/80/90/100/120 mm 086-130-05
Ø 1,8 x 70/80/90/100/120 mm 086-130-06
Ø 2,0 x 70/80/90/100/120 mm 086-130-07

Kanülen zur Lumbalpunktion
Lumbar puncture needles
Agujas para punción lumbar
Aghi per punture lombari



QUINKE

Ø 1,20 x 76 mm	086-120-01
Ø 1,20 x 89 mm	086-120-02
Ø 1,00 x 76 mm	086-120-03
Ø 1,00 x 89 mm	086-120-04
Ø 0,70 x 76 mm	086-120-05
Ø 0,70 x 50 mm	086-120-06
Ø 0,70 x 89 mm	086-120-07

Kanülen zur Lumbalpunktion
Lumbar puncture needles
Agujas para punción lumbar
Aghi per punture lombari

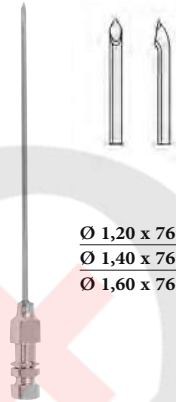

TUHOJ

Ø 1,20 x 76 mm	086-090-12
Ø 1,40 x 76 mm	086-090-14
Ø 1,60 x 76 mm	086-090-16

Kanülen zur Leberblindpunktion
Liver blind puncture needles
Agujas para punción ciega del hígado
Aghi per punture cieca del fegato



MENGHINI

Ø 1,00 x 35 mm	086-115-01
Ø 1,00 x 70 mm	086-115-02
Ø 1,20 x 70 mm	086-115-03
Ø 1,20 x 100 mm	086-115-04
Ø 1,40 x 70 mm	086-115-05
Ø 1,40 x 100 mm	086-115-06
Ø 1,60 x 70 mm	086-115-07
Ø 1,60 x 100 mm	086-115-08

Kanülen zur gezielten Leberpunktion
Needles for controlled liver puncture
Agujas para la punción del hígado bajo el control laparoscópico
Aghi per la punture controllata del fegato



MENGHINI

Ø 1,40 x 168 mm	086-117-14
Ø 1,80 x 168 mm	086-117-18

Trokare für Kanülen
Trocars for needles
Trocares para agujas
Trequarti oer aghi



Ø 1,40 x 168 mm	086-230-14
Ø 1,80 x 168 mm	086-230-18



11 ml	087-051-01
12 ml	087-051-02
15 ml	087-051-05
10 ml	087-051-10
20 ml	087-051-20
50 ml	087-051-50



11 ml	087-001-01
12 ml	087-001-02
15 ml	087-001-05
10 ml	087-001-10
20 ml	087-001-20
50 ml	087-001-50



11 ml	087-061-01
12 ml	087-061-02



LUER

11 ml	087-050-01
12 ml	087-050-02
15 ml	087-050-05
10 ml	087-050-10
20 ml	087-050-20
50 ml	087-050-50



LUER-LOCK

11 ml	087-000-01
12 ml	087-000-02
15 ml	087-000-05
10 ml	087-000-10
20 ml	087-000-20
50 ml	087-000-50



LUER-LOCK

12 ml	087-055-02
15 ml	087-055-05
10 ml	087-055-10

INSULIN LUER



11 ml	087-060-01
12 ml	087-060-02

SURGICAL INSTRUMENTS

SURGICAL INSTRUMENTS



150 ml	087-071-05
100 ml	087-071-10
150 ml	087-071-15
200 ml	087-071-20



10 ml	087-081-10
20 ml	087-081-20
30 ml	087-081-30
50 ml	087-081-50



JANET

150 ml	087-070-05
100 ml	087-070-10
150 ml	087-070-15
200 ml	087-070-20

Zwischenstück, LUER-LOCK weiblich
 Connecting piece, LUER-LOCK female
 Pieza de conexión, LUER-LOCK hembra
 Raccordo, LUER-LOCK femmina



087-911-00

Zwischenstück, LUER-LOCK männlich
 Connecting piece, LUER-LOCK male
 Pieza de conexión, LUER-LOCK masculino
 Raccordo, LUER-LOCK maschio



087-930-02

Zwischenstück, LUER-LOCK männlich
 Connecting piece, LUER-LOCK male
 Pieza de conexión, LUER-LOCK masculino
 Raccordo, LUER-LOCK maschio

Ø 6 mm

Ø 8 mm



087-912-06



087-912-08

Zwischenstück, LUER-LOCK weiblich
 Connecting piece, LUER-LOCK female
 Pieza de conexión, LUER-LOCK hembra
 Raccordo, LUER-LOCK femmina



087-913-00

Zwischenstück, LUER-LOCK männlich
 Connecting piece, LUER-LOCK male
 Pieza de conexión, LUER-LOCK masculino
 Raccordo, LUER-LOCK maschio



087-935-00

Durchflußhahn, LL männl. - LL weibl.
 Stopcock, LL male - LL female
 Llave, LL masculino - LL hembra
 Rubinetto, LL maschio - LL femmina



087-939-00

Durchflußhahn, LL weiblich
 Stopcock, LL female
 Llave, LL hembra
 Rubinetto, LL femmina



087-920-00

Dreiweghahn, 1 LL männl. - 2 LL weibl.
 Three-way-stopcock, 1 LL male - 2 LL female
 Llave de 3 vías, 1 LL masculino - 2 LL hembra
 Rubinetto a tre vie, 1 LL maschio - 2 LL femmina



087-922-00

Dreiweghahn, 3 LL weiblich
 Three-way-stopcock, 3 LL female
 Llave de 3 vías, 3 LL hembra
 Rubinetto a tre vie, 3 LL femmina



087-926-00

SURGICAL INSTRUMENTS

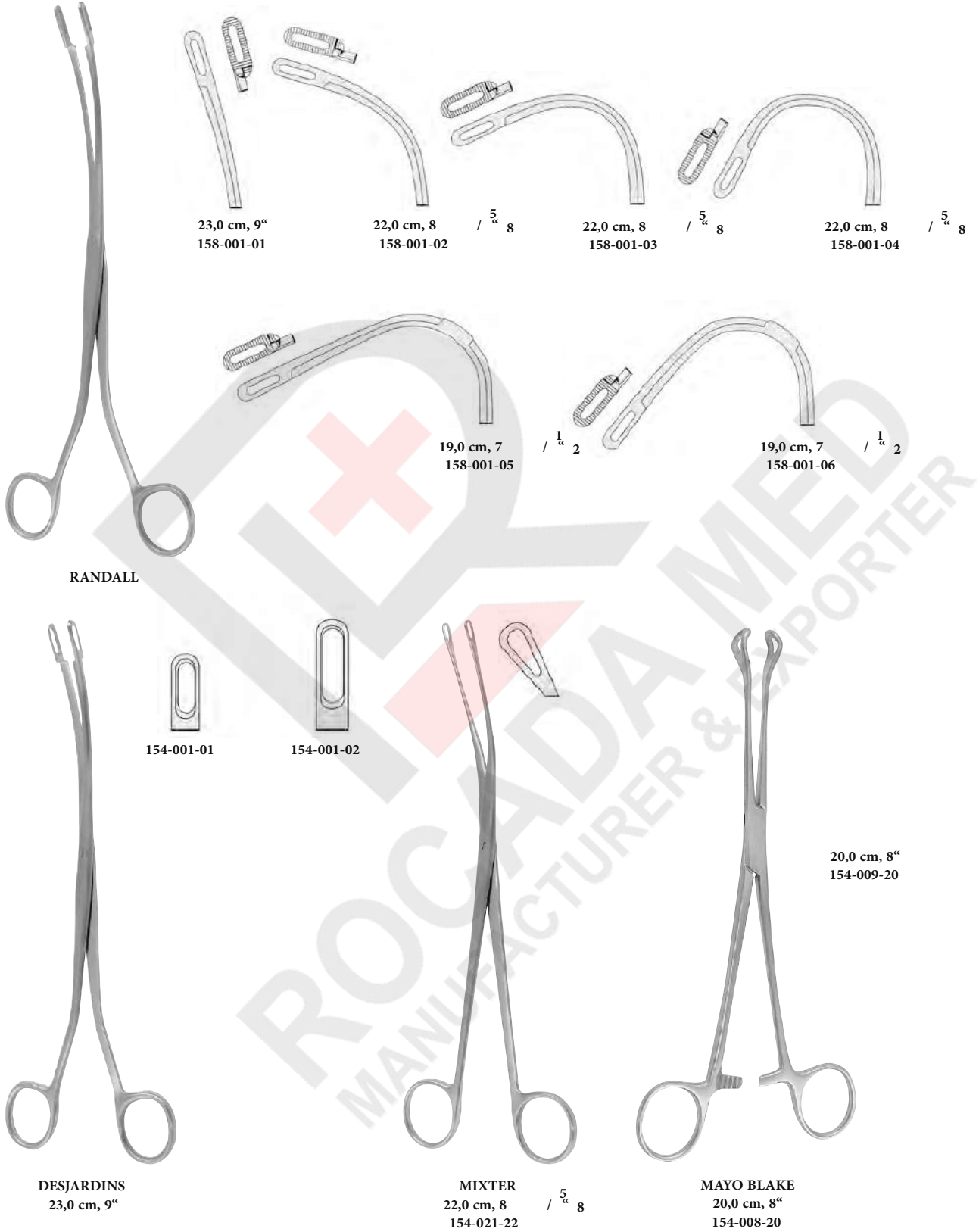

SURGICAL INSTRUMENTS



BLAKE
20,0 cm, 8"
154-006-20

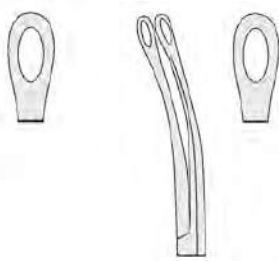

20,0 cm, 8"
154-005-20



TURNER-WARWICK
18,0 cm, 7"

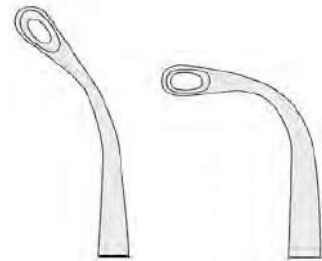

154-031-01

154-031-03



CZERNY
24,5 cm, 9" / 5" 8"
154-039-24



SURGICAL INSTRUMENTS

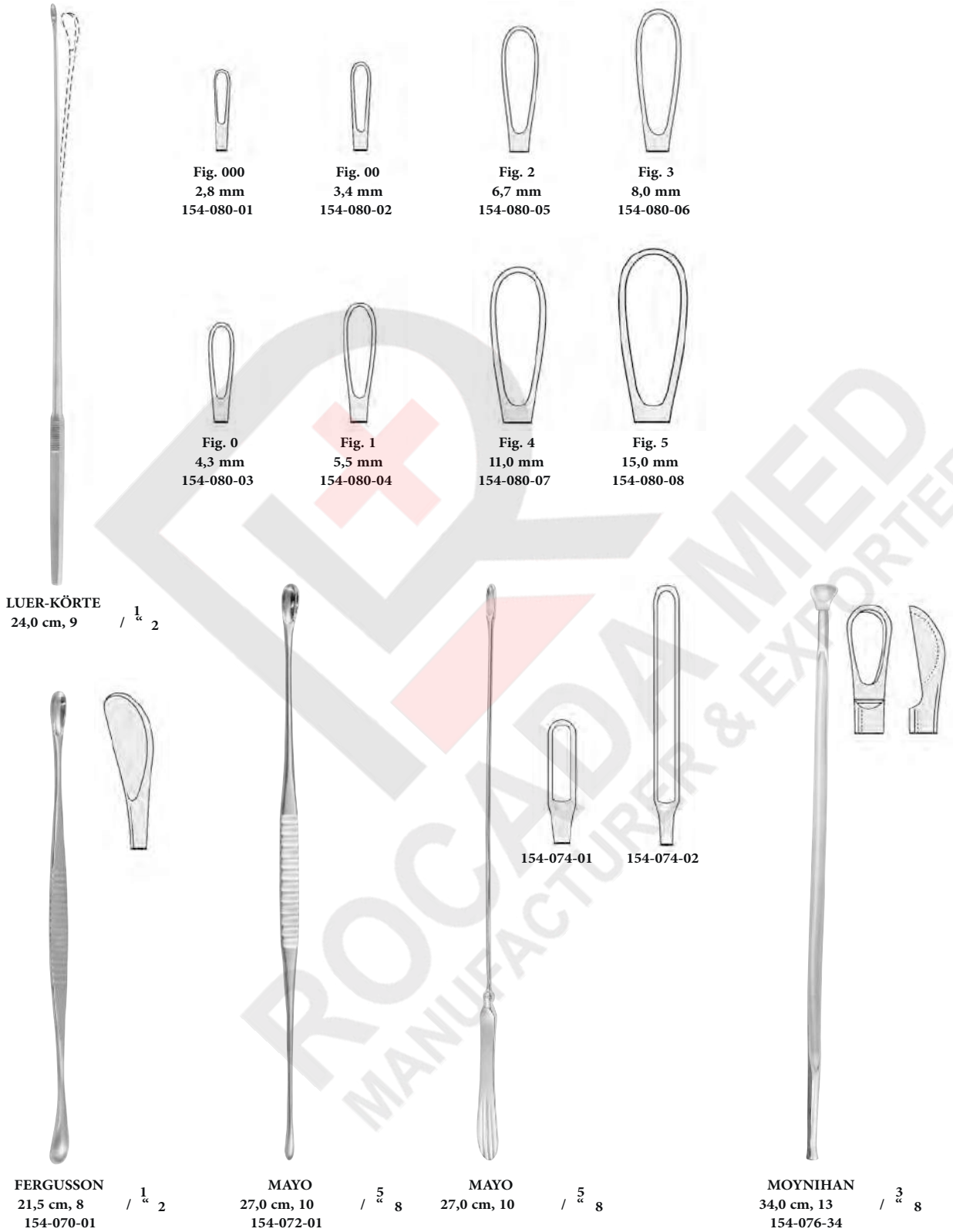



MAYO
 32,0 cm, 12
 154-078-32

1 / 2



OCHSNER
 35,0 cm, 13
 154-082-35

3 / 4



DESJARDINS
 28,0 cm, 11"



13 Char.
 154-056-13

18 Char.
 154-056-18

21 Char.
 154-056-21



MOORE
 30,0 cm, 12"
 154-084-30

Gallenblasenlöffel
 Gall bladder scoope
 Cuccharilla para la vesicula biliar
 Cucchiaio per colecisti



DESJARDINS
 28,0 cm, 11"

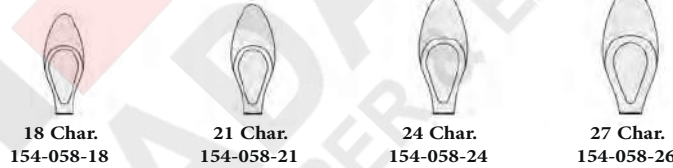

18 Char.
 154-058-18

21 Char.
 154-058-21

24 Char.
 154-058-24

27 Char.
 154-058-26

SURGICAL INSTRUMENTS



Ø 1,0 mm
154-050-01



Ø 2,0 mm
154-050-02



Ø 3,0 mm
154-050-03



Ø 4,0 mm
154-050-04



Ø 5,0 mm
154-050-05



Ø 6,0 mm
154-050-06



Ø 7,0 mm
154-050-07



Ø 8,0 mm
154-050-08



Ø 9,0 mm
154-050-09



Ø 10,0 mm
154-050-10



Ø 11,0 mm
154-050-11



Ø 12,0 mm
154-050-12



Ø 13,0 mm
154-050-13



BAKES
30,0 cm, 11 / 3 4

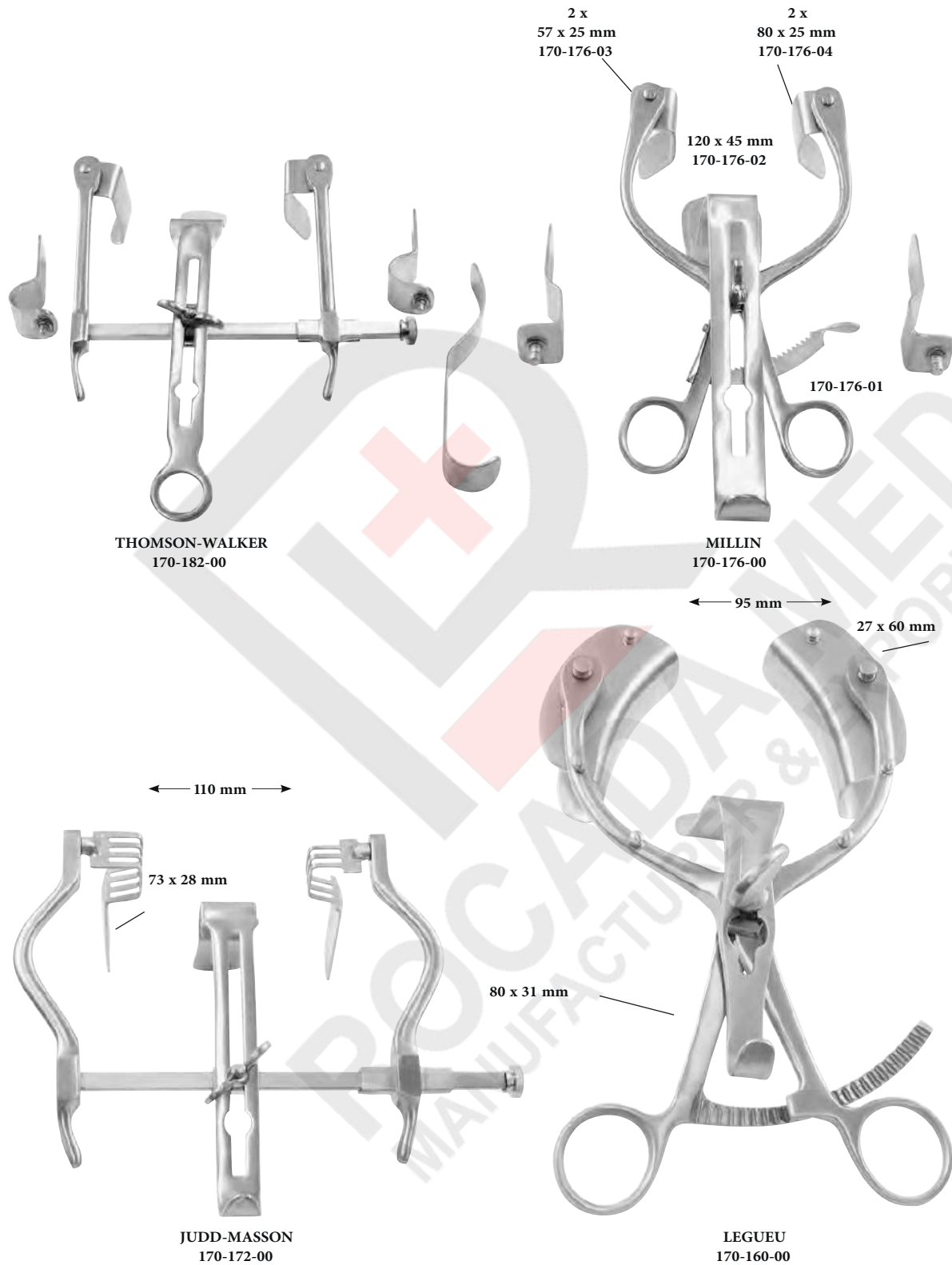

SURGICAL INSTRUMENTS

SURGICAL INSTRUMENTS

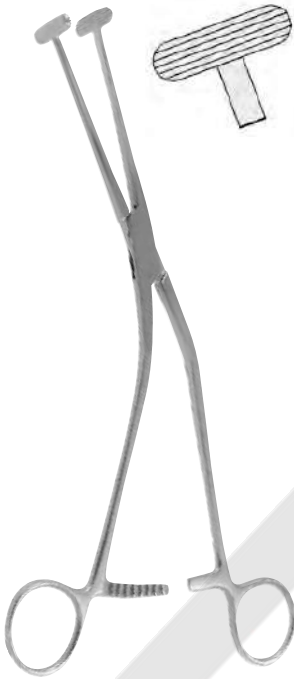

MILLIN
23,0 cm, 9"
170-073-23



ATRAUMA

MILLIN
24,0 cm, 9" / 1/2
170-071-24



MILLIN
24,0 cm, 9" / 1/2
170-077-24



MILLIN
23,0 cm, 9"
170-075-23



MILLIN
28,5 cm, 11" / 4
170-150-24

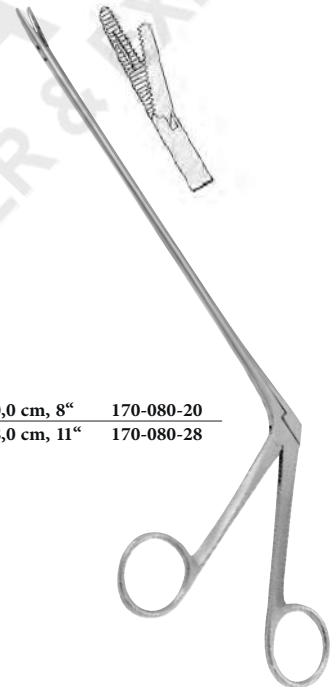

20,0 cm, 8" 170-080-20
28,0 cm, 11" 170-080-28

MATHIEU



YOUNG
21,0 cm, 8 / $\frac{1}{4}$ 4
170-230-21



YOUNG
22,0 cm, 8 / $\frac{5}{8}$ 8
170-236-22



YOUNG
21,0 cm, 8 / $\frac{1}{4}$ 4
170-238-21



YOUNG
22,0 cm, 8 / $\frac{5}{8}$ 8
170-240-22



90 x 35 mm

LEGUEU
26,0 cm, 10 / $\frac{1}{4}$ 4
170-250-26



90 x 61 mm

KOCHER
23,5 cm, 9 / $\frac{1}{4}$ 4
170-257-23

SURGICAL INSTRUMENTS

SURGICAL INSTRUMENTS



29,0 cm, 11

für Männer
for men
para hombres
per uomini

Char. 18	170-650-08
Char. 10	170-650-10
Char. 12	170-650-12
Char. 14	170-650-14
Char. 16	170-650-16
Char. 18	170-650-18
Char. 20	170-650-20
Char. 22	170-650-22
Char. 24	170-650-24

/ 1/4 2



16,0 cm, 6

für Frauen
for women
para mujeres
per donne

Char. 16	170-660-06
Char. 17	170-660-07
Char. 18	170-660-08
Char. 19	170-660-09
Char. 10	170-660-10
Char. 11	170-660-11
Char. 12	170-660-12
Char. 13	170-660-14
Char. 15	170-660-15
Char. 16	170-660-16
Char. 18	170-660-18
Char. 20	170-660-20
Char. 24	170-660-24

/ 1/4 4



STRAUSS
11,0 cm, 4
170-349-11

/ 1/4 3

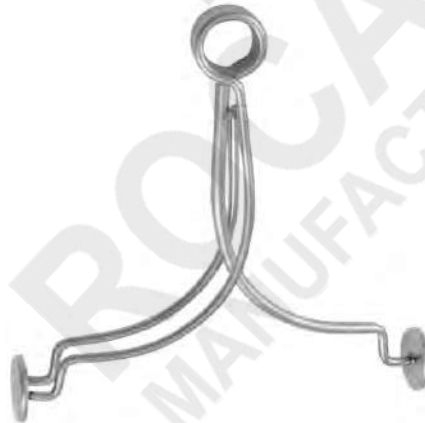

STOCKMANN
8,0 cm, 3
170-345-08

/ 1/4 4



COMCO

Ø 8,0 mm	170-350-08
Ø 11,0 mm	170-350-11
Ø 13,0 mm	170-350-13
Ø 16,0 mm	170-350-16
Ø 21,0 mm	170-350-21
Ø 26,0 mm	170-350-26
Ø 32,0 mm	170-350-32

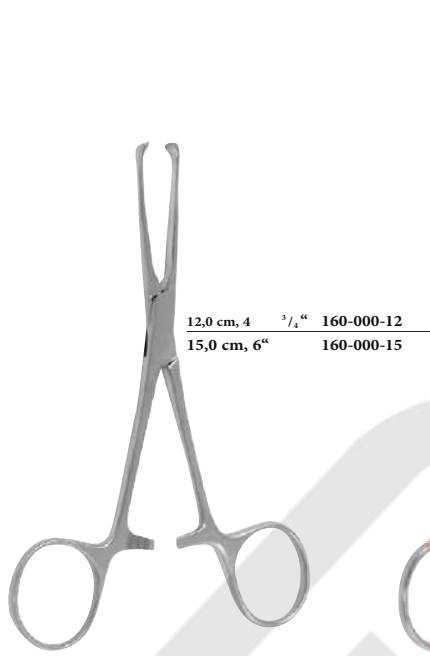

ALLIS-BABY

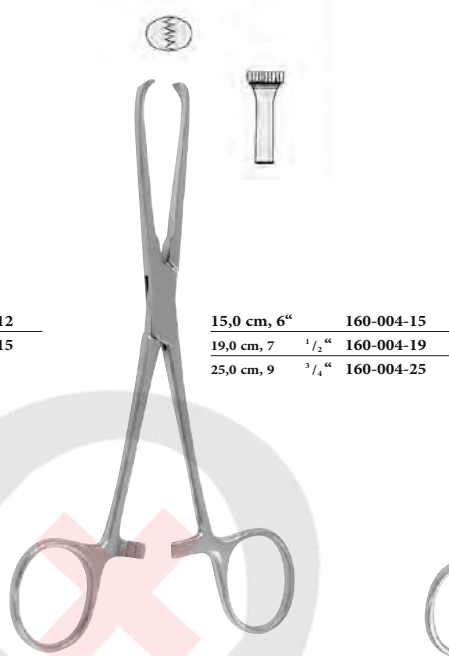

ALLIS

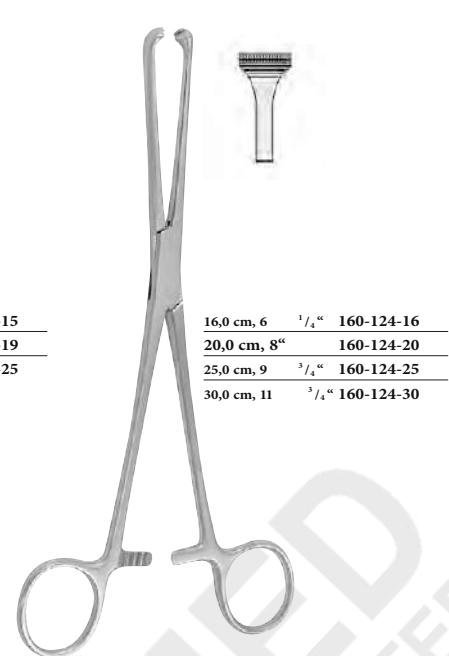

ALLIS-ATRAUMA

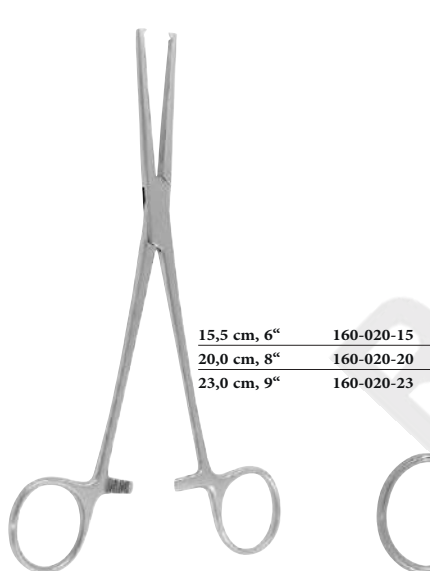

ALLEN

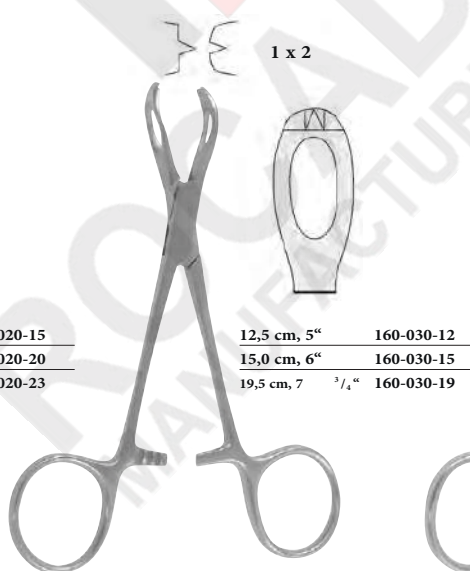

LANE

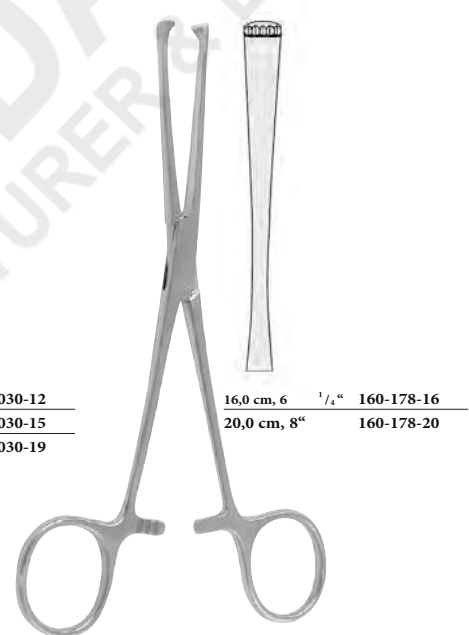

LOCKWOOD-ALLIS

SURGICAL INSTRUMENTS

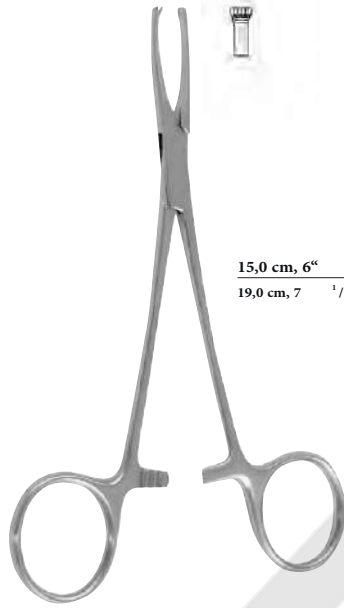

15,0 cm, 6" 160-040-15
19,0 cm, 7 1/2" 160-040-19

JUDD-ALLIS

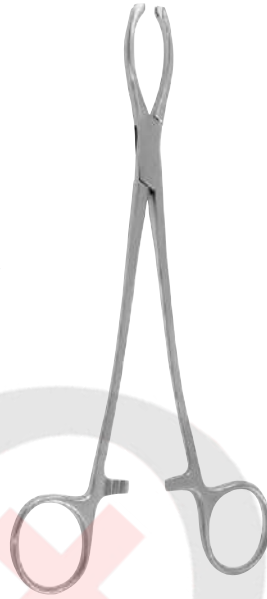

LITTLEWOOD
18,5 cm, 7 1/4" 160-060-16

6 x 7



ALLIS-ADAIR
15,5 cm, 6" 160-010-15



BOYS-ALLIS
15,5 cm, 6" 160-012-15



THOMS-ALLIS
20,0 cm, 8" 160-050-20



ALLIS
20,0 cm, 8" 160-014-20

SURGICAL INSTRUMENTS



LOCKWOOD
 20,0 cm, 8"
 160-169-20



WILLIAMS
 16,0 cm, 6" / 1/4"
 160-070-16



16,0 cm, 6"	1/4"	160-006-16
18,0 cm, 7"		160-006-18
20,0 cm, 8"		160-006-20
24,0 cm, 9"	1/2"	160-006-24

BABCOCK



BABCOCK-ATRAUMA

16,0 cm, 6"	1/4"	164-006-16
20,0 cm, 8"		164-006-20



BABCOCK-T C

16,0 cm, 6"	1/4"	161-006-16
20,0 cm, 8"		161-006-20



DUVAL-TC
 20,0 cm, 8"
 161-170-20

SURGICAL INSTRUMENTS

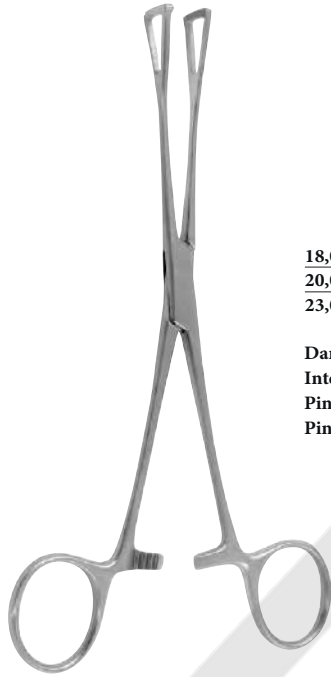

DUVAL

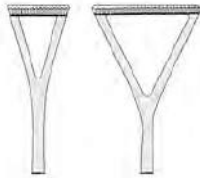

18,0 cm, 7"	160-170-18	
20,0 cm, 8"	160-170-20	160-172-20
23,0 cm, 9"		160-172-23

Darm- und Gewebefaszangen
Intestinal and Tissue Grasping Forceps
Pinzas intestinales y para tejidos
Pinze da presa per intestino e tessuti



BABY-DOYEN
18,0 cm, 7"

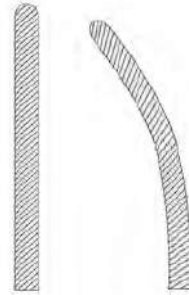

160-200-18

160-201-18



DOYEN

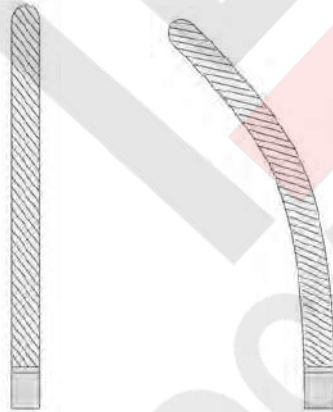

21,0 cm, 8 1/4"	160-210-21	21,0 cm, 8 1/4"	160-21	1-21
23,0 cm, 9"	160-210-23	23,0 cm, 9"	160-21	1-23

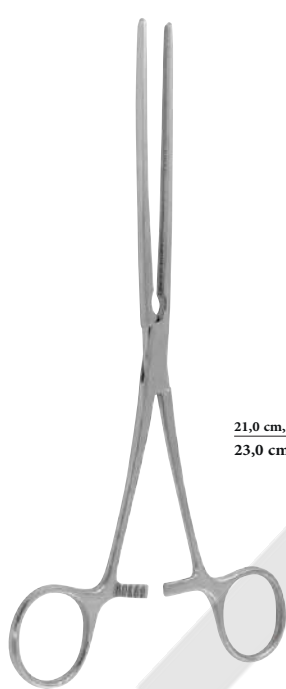

DOYEN

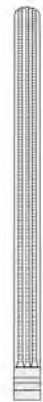

21,0 cm, 8 ¹/₄" 164-210-21
 23,0 cm, 9" 164-210-23

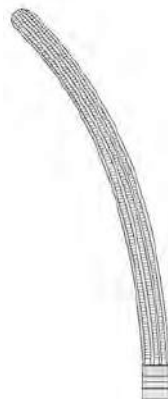

21,0 cm, 8 ¹/₄" 164-211-21
 23,0 cm, 9" 164-211-23

mit atraumatischer Zahnung
 with atraumatic serration
 con bacos atraumáticos
 con morsi atraumatici



KOCHER



22,0 cm, 8 ⁵/₁₆" 160-234-22
 25,0 cm, 9 ³/₁₆" 160-234-25
 28,0 cm, 11" 160-234-28



22,0 cm, 8 ⁵/₁₆" 160-235-22
 25,0 cm, 9 ³/₁₆" 160-235-25
 28,0 cm, 11" 160-235-28

SURGICAL INSTRUMENTS



mit atraumatischer Zahnung
with atraumatic serration
con bacos atraumáticas
con morsi atraumatici

KOCHER



22,0 cm, 8	$\frac{5}{8}$ "	164-234-22	22,0 cm, 8	$\frac{5}{8}$ "	164-235-22
25,0 cm, 9	$\frac{3}{4}$ "	164-234-25	25,0 cm, 9	$\frac{3}{4}$ "	164-235-25
28,0 cm, 11"		164-234-28	28,0 cm, 11"		164-235-28



MAYO-ROBSON



21,0 cm, 8	$\frac{1}{4}$ "	160-230-21	21,0 cm, 8	$\frac{1}{4}$ "	160-231-21
23,0 cm, 9"		160-230-23	23,0 cm, 9"		160-231-23
25,0 cm, 9	$\frac{3}{4}$ "	160-230-25	25,0 cm, 9	$\frac{3}{4}$ "	160-231-25

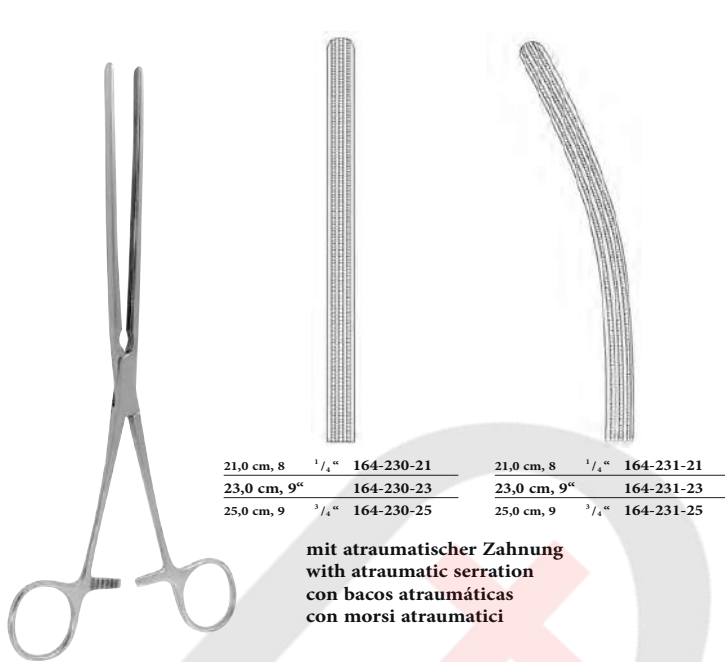

21,0 cm, 8	1/4"	164-230-21	21,0 cm, 8	1/4"	164-231-21
23,0 cm, 9"		164-230-23	23,0 cm, 9"		164-231-23
25,0 cm, 9	3/4"	164-230-25	25,0 cm, 9	3/4"	164-231-25

mit atraumatischer Zahnung
 with atraumatic serration
 con bacos atraumáticos
 con morsi atraumatici

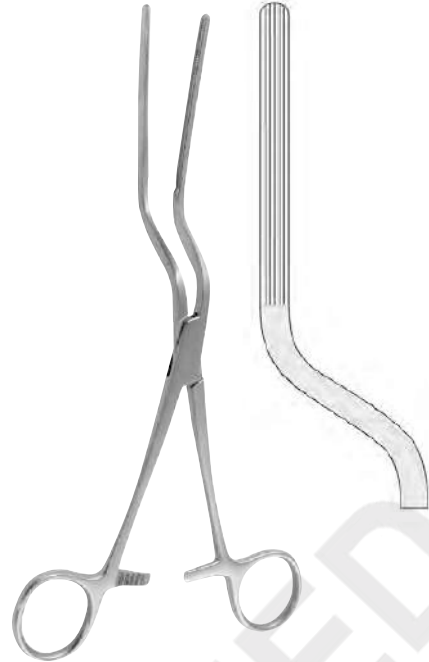

BRUNNER
 24,0 cm, 9 / 1/2"
 160-240-24

MAYO-ROBSON

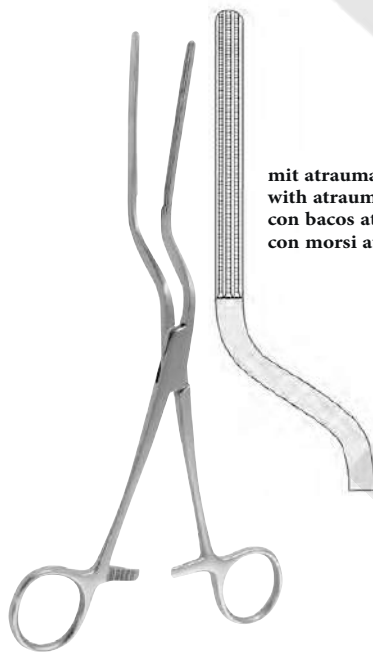

BRUNNER
 24,0 cm, 9 / 1/2"
 164-240-24

mit atraumatischer Zahnung
 with atraumatic serration
 con bacos atraumáticos
 con morsi atraumatici

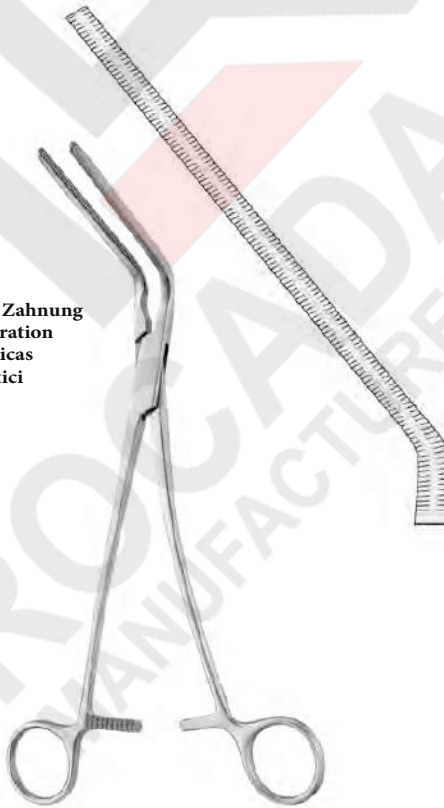

GLASSMAN
 23,0 cm, 9"
 160-259-23



GLASSMAN
 23,5 cm, 9 / 1/4"
 160-253-23



Maullänge
length of jaws
longitud de la boca
bocche lungh

15,0 cm, 2"	160-320-05
17,0 cm, 2 1/2"	160-320-07
10,0 cm, 4"	160-320-10

DE MARTEL-WOLFSON



DE MARTEL-WOLFSON
8,5 cm, 3 1/4" 2
160-340-08



DE MARTEL-WOLFSON
26,0 cm, 10 1/4" 4
160-325-26

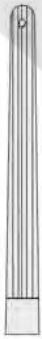

160-310-15
mit Stift
with pin
con espiga
con perno



160-311-15
ohne Stift
without pin
sin espiga
senza perno



BABY-PAYR
15,0 cm, 6"

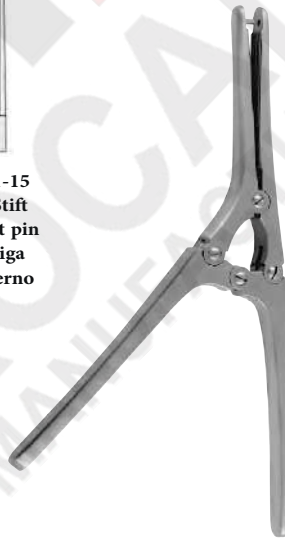

PAYR



21,0 cm, 8 1/4" 160-310-21
29,0 cm, 11 1/2" 160-310-29



160-311-21
160-311-29

mit Stift
with pin
con espiga
con perno

ohne Stift
without pin
sin espiga
senza perno

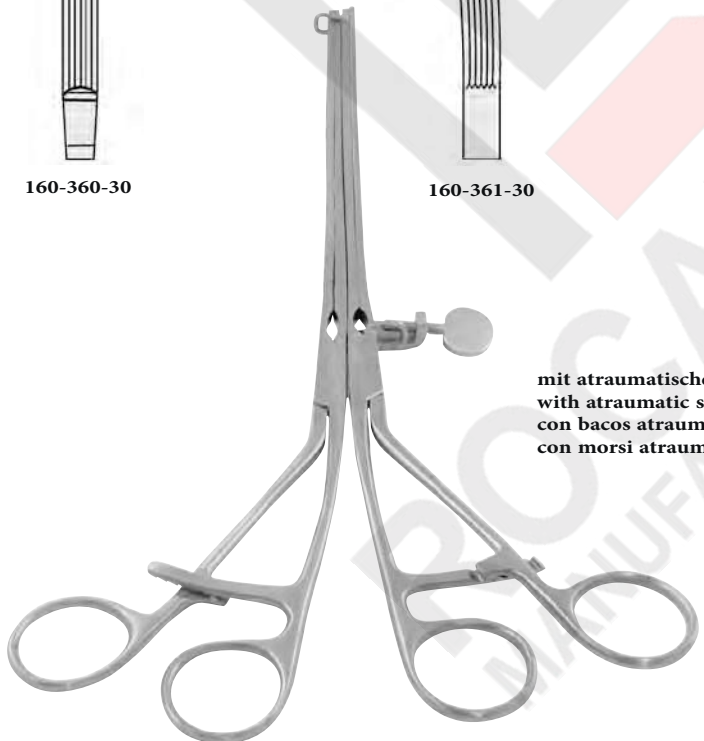

LANE
30,0 cm, 11 / 3 4



SCUDDER
33,0 cm, 13"

mit atraumatischer Zahnung
with atraumatic serration
con bacos atraumáticos
con morsi atraumatici

SURGICAL INSTRUMENTS



MIKULICZ
19,0 cm, 7 1/2
168-010-19

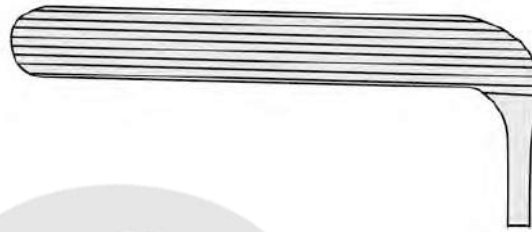

HAYES

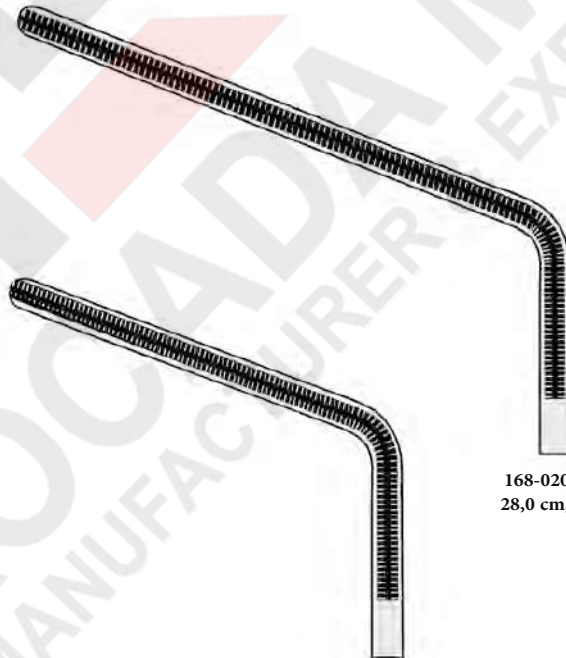

168-020-28
28,0 cm, 11"

168-020-26
26,0 cm, 10"

SURGICAL INSTRUMENTS

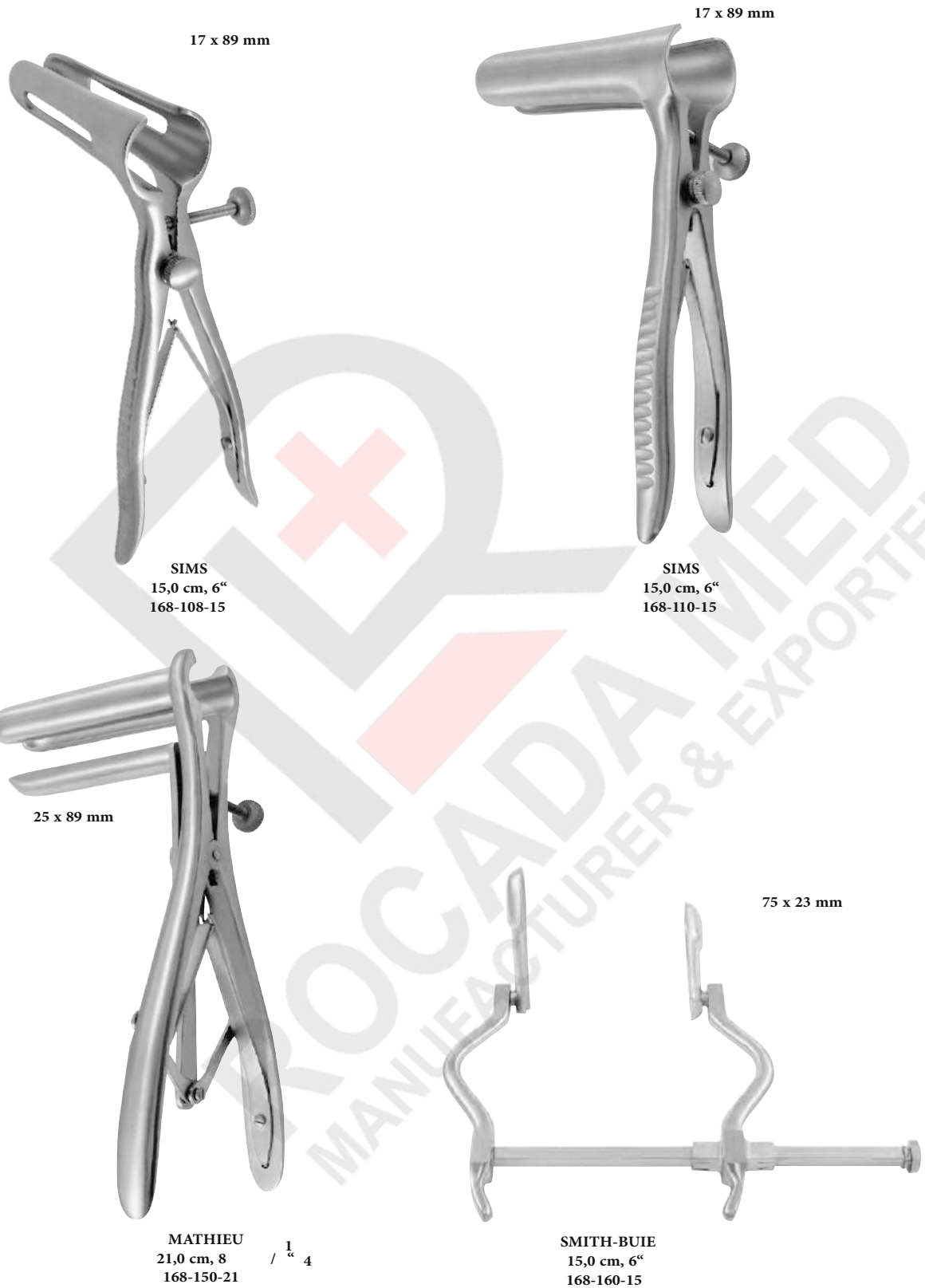

SURGICAL INSTRUMENTS

SURGICAL INSTRUMENTS

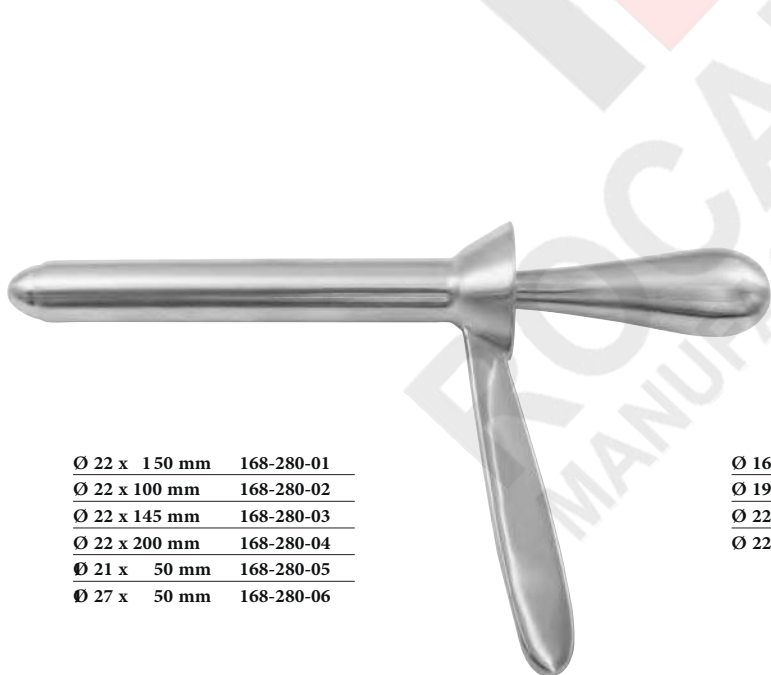
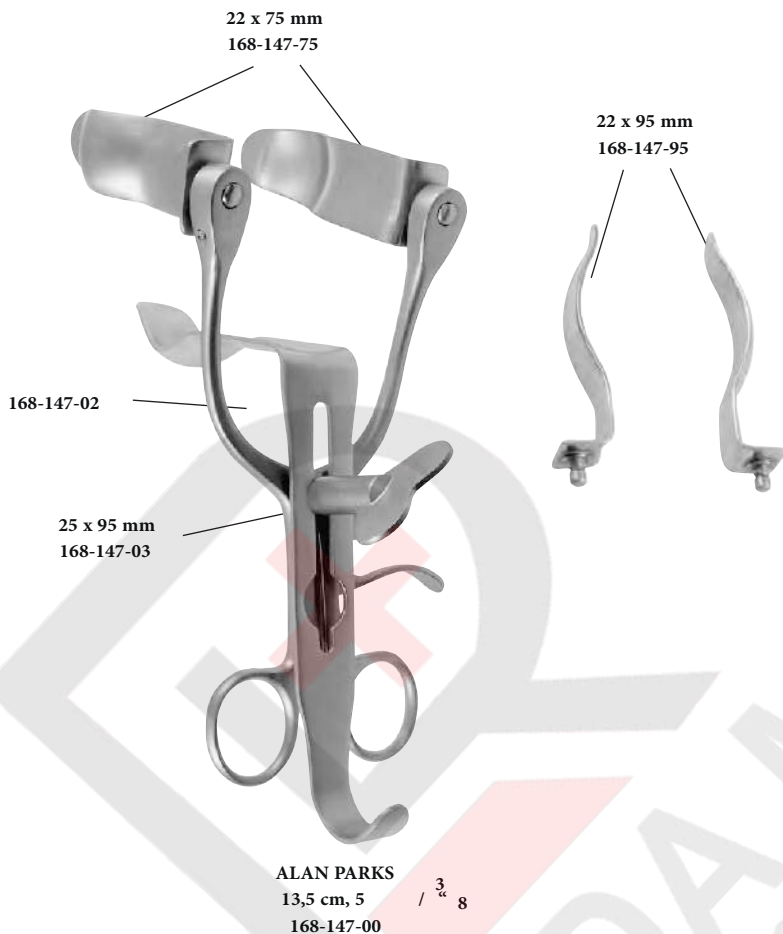

HAYES

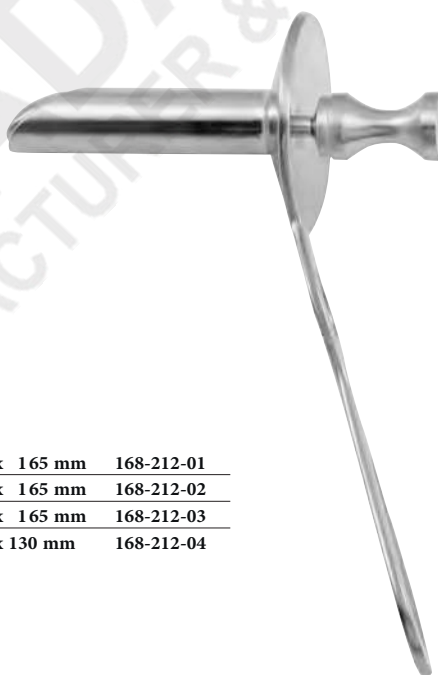

HIRSCHMANN

Ø 22 x 150 mm	168-280-01
Ø 22 x 100 mm	168-280-02
Ø 22 x 145 mm	168-280-03
Ø 22 x 200 mm	168-280-04
Ø 21 x 50 mm	168-280-05
Ø 27 x 50 mm	168-280-06

Ø 16 x 165 mm	168-212-01
Ø 19 x 165 mm	168-212-02
Ø 22 x 165 mm	168-212-03
Ø 22 x 130 mm	168-212-04

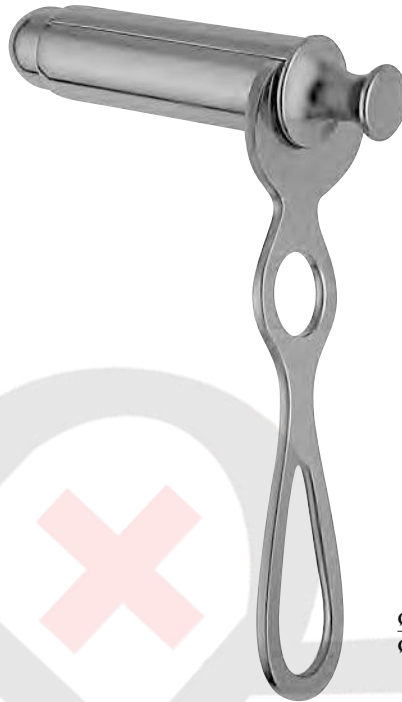

Ø 22 x 65 mm	168-250-22
Ø 30 x 65 mm	168-250-30

CHELSEA EATON

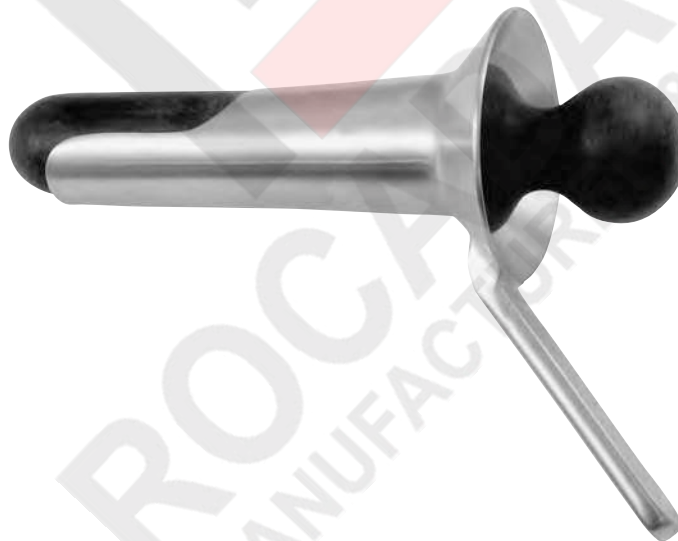

ohne Kaltlichtträger
without cold light carrier
sin portador para luz fría
senza luce fredda

IVES FANSLER
Ø 22 mm
168-268-01

mit Kaltlichtträger
with cold light carrier
con portador para luz fría
con luce fredda

IVES FANSLER
Ø 22 mm
168-268-02



28,0 cm, 11"	168-300-28
35,0 cm, 13 3/4"	168-300-35
42,0 cm, 16 1/2"	168-300-42



28,0 cm, 11"	168-311-28
35,0 cm, 13 3/4"	168-311-35
42,0 cm, 16 1/2"	168-311-42



28,0 cm, 11"	168-301-28
35,0 cm, 13 3/4"	168-301-35
42,0 cm, 16 1/2"	168-301-42



28,0 cm, 11"	168-312-28
35,0 cm, 13 3/4"	168-312-35
42,0 cm, 16 1/2"	168-312-42

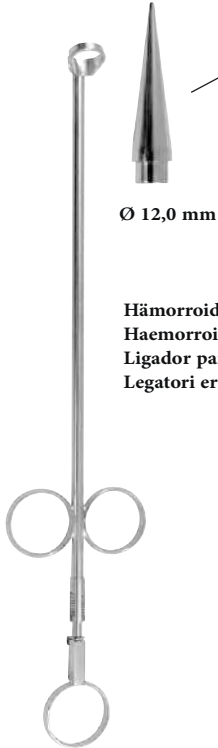

RUDD
168-400-00

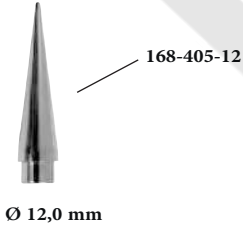

Hämorrhoiden-Ligator mit Ladekonus
Haemorrhoidal ligator with loading attachment
Ligador para hemorroides con cono de carga
Legatori ermorroidali con carica a cono



MC GIVNEY
168-410-00

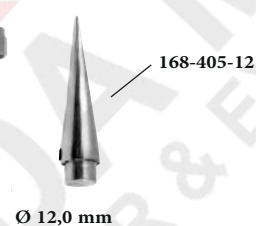

Hämorrhoiden-Ligator mit Ladekonus
Haemorrhoidal ligator with loading attachment
Ligador para hemorroides con cono de carga
Legatori ermorroidali con carica a cono

Hämorrhoiden-Faßzangen, Fistel­sonden
Haemorrhoidal Forceps, Fistula probes
Pinza-clamps para hemorroides, Sondas
Para fistula Pinze per emorroidi, Sonde
Per fistola

ROCADA MED
MANUFACTURER & EXPORTER



MC GIVNEY
19,0 cm, 7 / $\frac{1}{2}$ 2
168-471-19



MC GIVNEY
19,0 cm, 7 / $\frac{1}{2}$ 2
168-473-19



PRATT
21,0 cm, 8 / $\frac{1}{4}$ 4



080-135-01



080-135-02



080-135-03

SURGICAL INSTRUMENTS

für Jungfrauen
for virgins
para vírgenes
per vergini

für Kinder
for children
para niños
per bambini



COLLIN
65 x 10 mm
180-132-00



COLLIN
65 x 10 mm
180-134-00

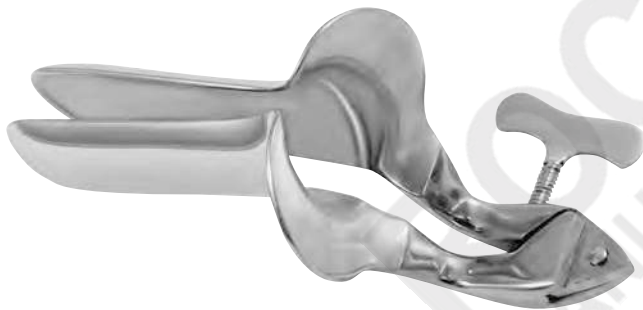

COLLIN

185 x 30 mm	180-130-01
100 x 35 mm	180-130-02
110 x 40 mm	180-130-03



180 x 24 mm	180-142-01
180 x 32 mm	180-142-02
198 x 16 mm	180-142-03
105 x 25 mm	180-142-04
107 x 29 mm	180-142-05
115 x 35 mm	180-142-06

zentrale Stellschraube
central fixation screw
tornillo de sujeto central
vite di regolazione centrale



CUSCO	
75 x 32 mm	180-144-01
85 x 36 mm	180-144-02
95 x 37 mm	180-144-03

seitliche Stellschraube
lateral fixation screw
tornillo de sujeto lateral
vite di regolazione laterale



für Jungfrauen
for virgins
para virgenes
per vergini

CUSCO	
75 x 17 mm	180-140-00

seitliche Stellschraube
lateral fixation screw
tornillo de sujeto lateral
vite di regolazione laterale



CUSCO	
75 x 32 mm	180-140-01
85 x 35 mm	180-140-02
100 x 35 mm	180-140-03

Schweizer Modell
Swiss pattern
Modelo suizo
Modello svizzero



CUSCO	
90 x 23-25 mm	180-146-01
100 x 25-27 mm	180-146-02
110 x 27-30 mm	180-146-03

SURGICAL INSTRUMENTS

SURGICAL INSTRUMENTS

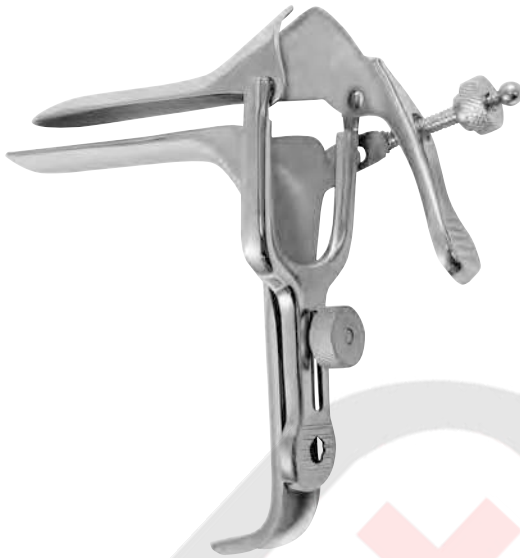

GRAVE

175 x 20 mm	180-100-01
195 x 35 mm	180-100-02
115 x 35 mm	180-100-03



PEDERSON

175 x 13 mm	180-120-01
100 x 22 mm	180-120-02
120 x 25 mm	180-120-03



SEMM

190 x 14-18 mm	180-150-01
100 x 17-20 mm	180-150-02
100 x 25-30 mm	180-150-03



WEISSBARTH

21,0 cm, 8 / 1/4 4	180-160-00
--------------------	------------



mit abnehmbarem Gewicht
with detachable weight
con peso desmontable
con peso smontabile

1,14 kg

AUVARD
75 x 38 mm
180-170-00



mit festem Gewicht
with fixed weight
con peso fijo
con peso fisso

1,14 kg

AUVARD
75 x 38 mm
180-172-00



180-180-03

400 g
180-180-40

800 g
180-180-80

SCHERBACK
180-180-00

koplett, complete, completo, completo

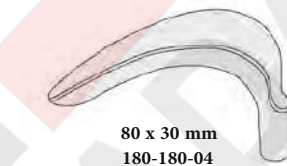

80 x 30 mm
180-180-04

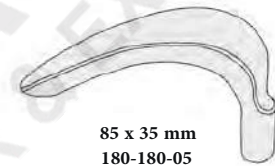

85 x 35 mm
180-180-05

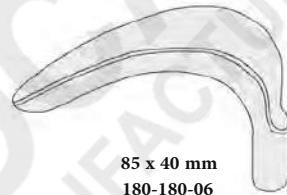

85 x 40 mm
180-180-06

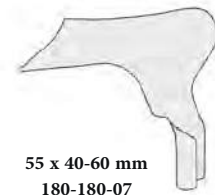

55 x 40-60 mm
180-180-07

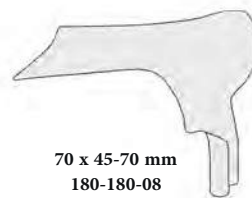

70 x 45-70 mm
180-180-08

SURGICAL INSTRUMENTS

Satz
Set
Juego
Set



KRISTELLER	
Fig. 1	180-220-01
Fig. 2	180-220-02
Fig. 3	180-220-03



KRISTELLER	
105 x 26 mm	180-221-01
105 x 28 mm	180-221-02
105 x 33 mm	180-221-03

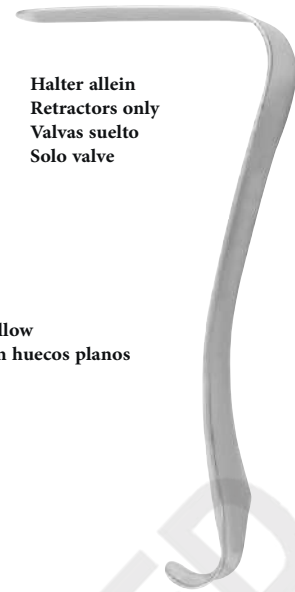

Halter allein
Retractors only
Valvas suelto
Solo valve

Spekula allein, flach
Specula only, flat hollow
Especúlos suelto, con huecos planos
Solo speculi, piatta

KRISTELLER	
115 x 22 mm	180-222-01
115 x 24 mm	180-222-02
115 x 29 mm	180-222-03

Satz
Set
Juego
Set



KRISTELLER	
Fig. 1	180-230-01
Fig. 2	180-230-02
Fig. 3	180-230-03

Spekula allein, flach
Specula only, flat hollow
Especúlos suelto, con huecos planos
Solo speculi, piatta

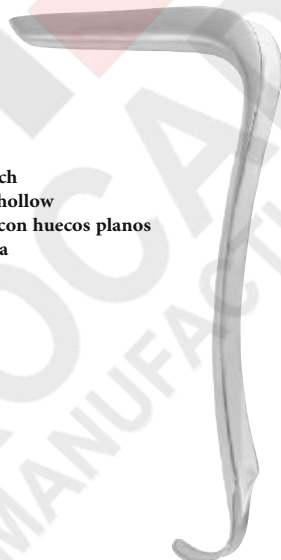

KRISTELLER	
110 x 27 mm	180-231-01
110 x 30 mm	180-231-02
110 x 36 mm	180-231-03



Halter allein
Retractors only
Valvas suelto
Solo valve

KRISTELLER	
115 x 23 mm	180-232-01
115 x 26 mm	180-232-02
115 x 32 mm	180-232-03



Satz
Set
Juego
Set

KRISTELLER	
Fig. 0	180-234-00
Fig. 1	180-234-01
Fig. 2	180-234-02
Fig. 3	180-234-03



Spekula allein
Specula only
Especúlos suelto
Solo speculi

KRISTELLER	
70 x 15 mm	180-235-00
70 x 27 mm	180-235-01
80 x 30 mm	180-235-02
90 x 36 mm	180-235-03



Halter allein
Retractors only
Valvas suelto
Solo valve

KRISTELLER	
175 x 10 mm	180-236-00
175 x 23 mm	180-236-01
185 x 26 mm	180-236-02
100 x 32 mm	180-236-03

konisch, für Jungfrauen
conical blades, vor virgins
valvos cónicos, para virgenes
valve coniche, per vergini



Satz
Set
Juego
Set

KRISTELLER	
Fig. 00	180-237-01
Fig. 0	180-237-02

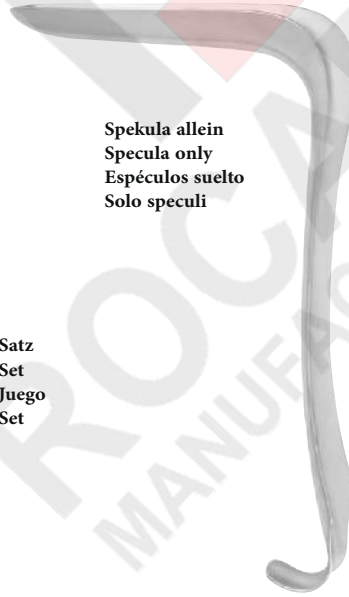

Spekula allein
Specula only
Especúlos suelto
Solo speculi

KRISTELLER	
105 x 18 mm	180-238-01
105 x 21 mm	180-238-02

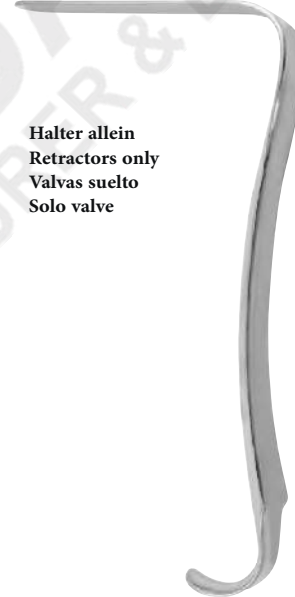

Halter allein
Retractors only
Valvas suelto
Solo valve

KRISTELLER	
110 x 14 mm	180-239-01
110 x 17 mm	180-239-02



leicht hohl
slightly-concave
ligeremente concavos
leggeremente concavi

Fig	a x b	
1	155 x 35 mm	180-260-01
2	185 x 35 mm	180-260-02
3	115 x 35 mm	180-260-03

1	155 x 45 mm	180-261-01
2	185 x 45 mm	180-261-02
3	115 x 45 mm	180-261-03
4	160 x 45 mm	180-261-04

1	155 x 60 mm	180-262-01
2	185 x 60 mm	180-262-02
3	115 x 60 mm	180-262-03
4	160 x 60 mm	180-262-04

DOYEN
23,0 cm, 9"



halb-hohl
medium-concave
semi-concavos
semi-concavi

Fig	a x b	
1	155 x 35 mm	180-264-01
2	185 x 35 mm	180-264-02
3	115 x 35 mm	180-264-03

1	155 x 45 mm	180-265-01
2	185 x 45 mm	180-265-02
3	115 x 45 mm	180-265-03

1	155 x 60 mm	180-266-01
2	185 x 60 mm	180-266-02
3	115 x 60 mm	180-266-03

DOYEN
23,0 cm, 9"



Satz
Set
Juego
Set

KALLMORGEN	
70 x 40 mm	180-270-01
90 x 40 mm	180-270-02



Spekula allein
Specula only
Especúlos suelto
Solo speculi

KALLMORGEN	
70 x 40 mm	180-271-01
90 x 40 mm	180-271-02

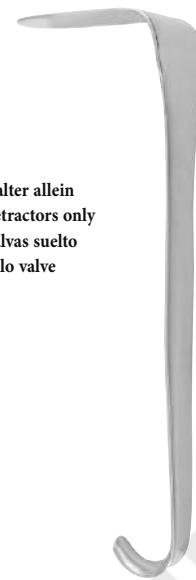

Halter allein
Retractors only
Valvas suelto
Solo valve

KALLMORGEN	
70 x 40 mm	180-272-01
90 x 40 mm	180-272-02



70 x 15 mm

KRISTELLER	
17,0 cm, 6	$\frac{3}{4}$
180-275-17	



75 x 39 mm

KALLMORGEN	
17,0 cm, 6	$\frac{3}{4}$
180-290-17	



JACKSON	
175 x 38 mm	180-290-01
190 x 38 mm	180-290-02
100 x 38 mm	180-290-03

76 x 25 mm



70 x 22 mm

BREISKY
14,0 cm, 5 / $\frac{1}{4}$ 2
180-292-01

82 x 30 mm



76 x 25 mm

BREISKY
14,0 cm, 5 / $\frac{1}{4}$ 2
180-292-02

95 x 38 mm

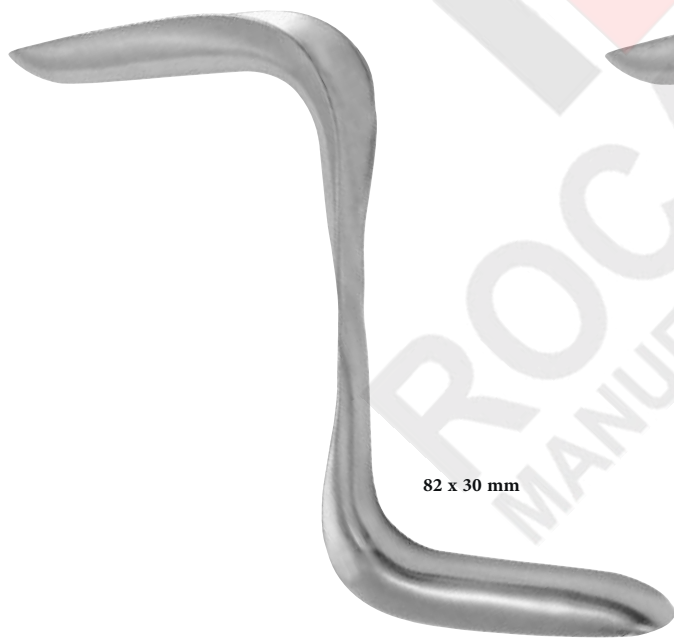

82 x 30 mm

BREISKY
17,0 cm, 6 / $\frac{3}{4}$ 4
180-292-03

102 x 44 mm

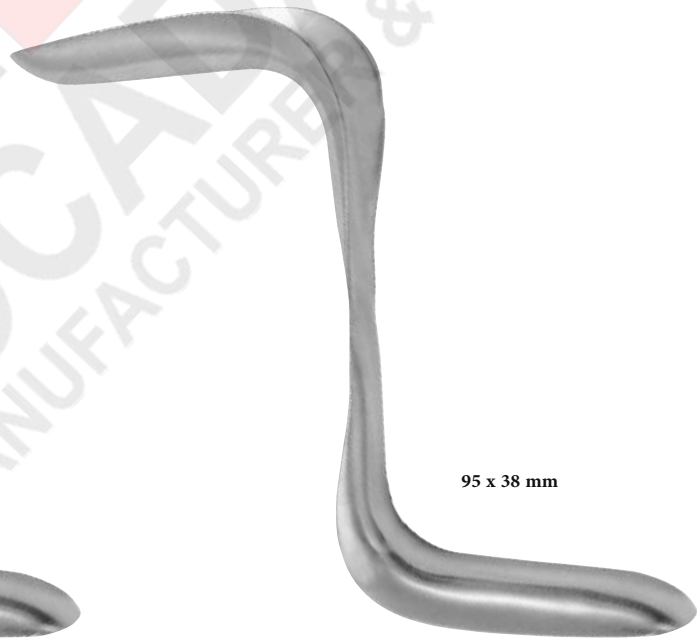

95 x 38 mm

BREISKY
17,0 cm, 6 / $\frac{3}{4}$ 4
180-292-04

SURGICAL INSTRUMENTS

SIMS
 57-8294-00
 Satz, Set, Juego, Set, Набор

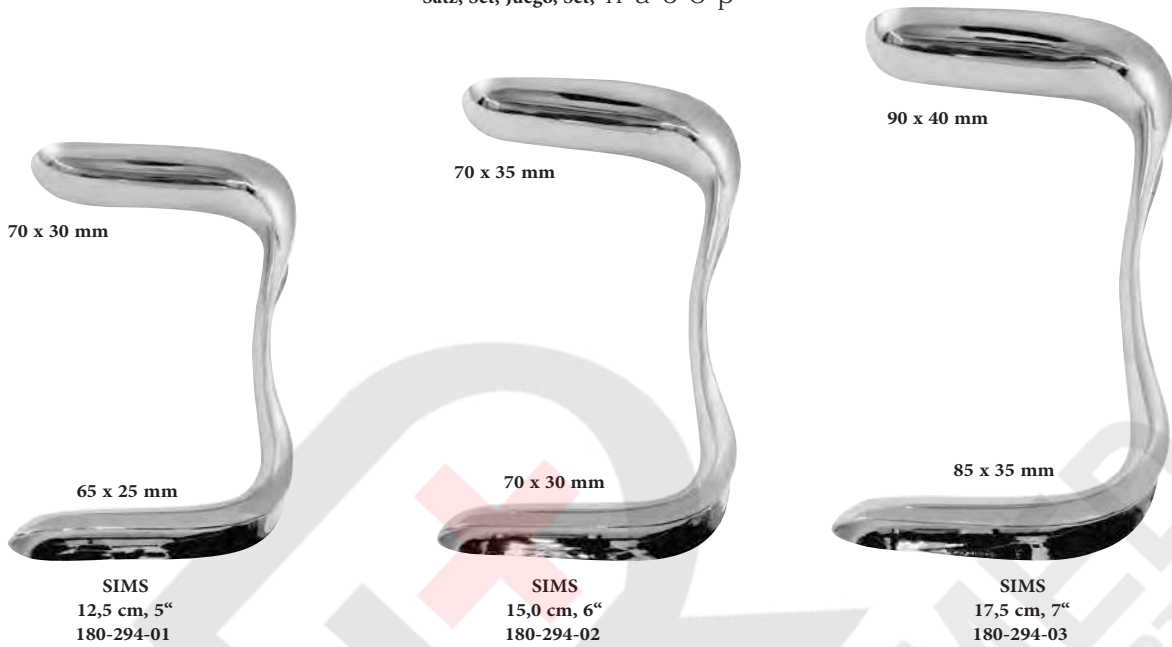

Spekula allein
 Specula only
 Espéculos suelto
 Solo speculi

MATHIEU
 100 x 13-23 mm 180-300-01
 100 x 16-30 mm 180-300-02



Halter allein
 Retractors only
 Valvas suelto
 Solo valve

MATHIEU
 100 x 11-21 mm 180-301-01
 100 x 14-27 mm 180-301-02



LANDAU
 100 x 28 mm 180-305-01
 100 x 38 mm 180-305-02

SURGICAL INSTRUMENTS



100 x 20 mm	180-307-20
100 x 25 mm	180-307-25
100 x 30 mm	180-307-30
100 x 35 mm	180-307-35
100 x 40 mm	180-307-40
130 x 20 mm	180-308-20
130 x 25 mm	180-308-25
130 x 30 mm	180-308-30
130 x 35 mm	180-308-35
130 x 40 mm	180-308-40
155 x 40 mm	180-309-40

BREISKY



85 x 17 mm

BRAUN, MODIF $\frac{1}{2}$
19,0 cm, 7 / $\frac{1}{4}$ 2
180-313-19



60 x 30 mm

DOYEN
23,0 cm, 9"
180-315-23



80 x 30 mm

DOYEN
25,0 cm, 9"
180-315-25



95 x 38 mm

WERTHEIM
30,0 cm, 12"
180-317-30

Endospekula, Lateral-Spekulum
Intrauterinsonde Endospecula
Lateral Speculum, Intrauterine Probe
Endoespéculos, Espéculo lateral, Sonda
Intra-uterina Endospeculi, Speculo lateral
Sonde intrauterine

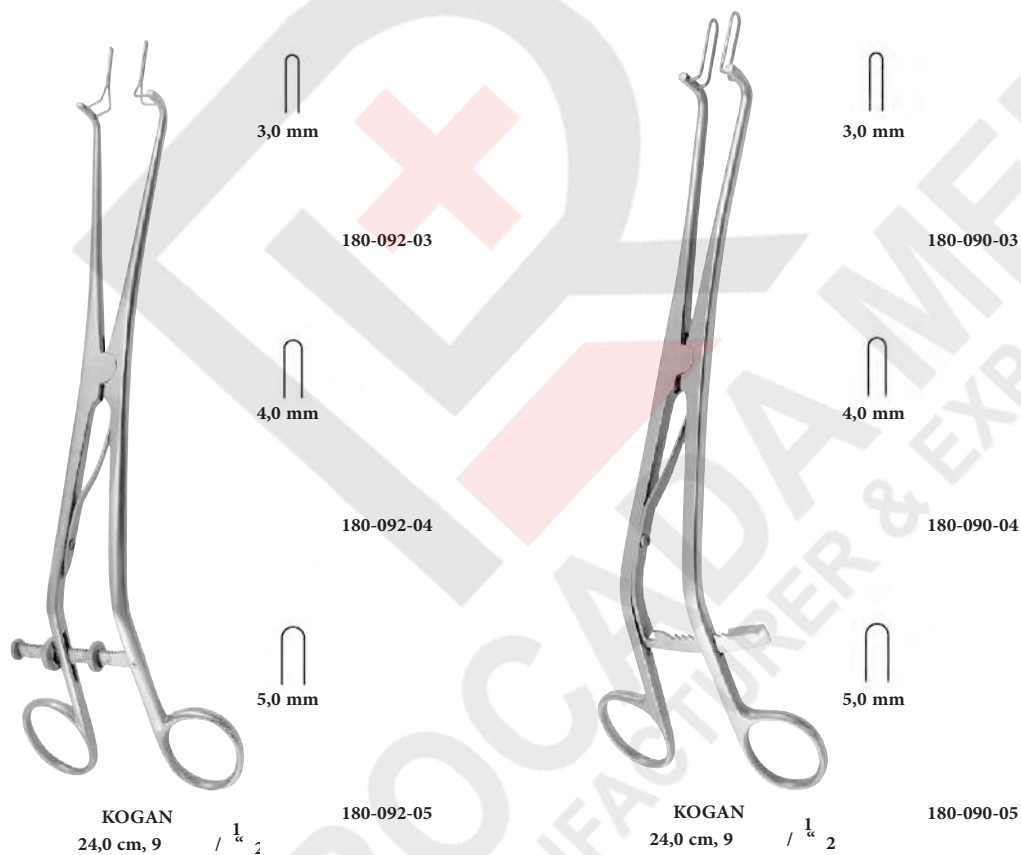

SURGICAL INSTRUMENTS



HEGAR
18,5 cm, 7 / $\frac{1}{4}$

Ø 1,0 mm	180-350-01
Ø 2,0 mm	180-350-02
Ø 3,0 mm	180-350-03
Ø 4,0 mm	180-350-04
Ø 5,0 mm	180-350-05
Ø 6,0 mm	180-350-06
Ø 7,0 mm	180-350-07
Ø 8,0 mm	180-350-08
Ø 9,0 mm	180-350-09
Ø 10,0 mm	180-350-10
Ø 11,0 mm	180-350-11
Ø 12,0 mm	180-350-12
Ø 13,0 mm	180-350-13
Ø 14,0 mm	180-350-14
Ø 15,0 mm	180-350-15
Ø 16,0 mm	180-350-16
Ø 17,0 mm	180-350-17
Ø 18,0 mm	180-350-18
Ø 19,0 mm	180-350-19
Ø 20,0 mm	180-350-20
Ø 21,0 mm	180-350-21
Ø 22,0 mm	180-350-22
Ø 23,0 mm	180-350-23
Ø 24,0 mm	180-350-24
Ø 25,0 mm	180-350-25
Ø 26,0 mm	180-350-26



HEGAR
18,5 cm, 7 / $\frac{1}{4}$

Ø 1,5 mm	180-351-01
Ø 2,5 mm	180-351-02
Ø 3,5 mm	180-351-03
Ø 4,5 mm	180-351-04
Ø 5,5 mm	180-351-05
Ø 6,5 mm	180-351-06
Ø 7,5 mm	180-351-07
Ø 8,5 mm	180-351-08
Ø 9,5 mm	180-351-09
Ø 10,5 mm	180-351-10
Ø 11,5 mm	180-351-11
Ø 12,5 mm	180-351-12
Ø 13,5 mm	180-351-13
Ø 14,5 mm	180-351-14
Ø 15,5 mm	180-351-15
Ø 16,5 mm	180-351-16
Ø 17,5 mm	180-351-17



205 x 105 x 45 mm

HEGAR
180-350-99
Satz, Set, Juego, Set
Ø 1,0 - Ø 26,0
(26 dilators)

HEGAR
180-350-98
Satz, Set, Juego, Set
Ø 4,0 - Ø 17,0
(14 dilators)



HEGAR
 20,0 cm, 8"

Ø 1,0 / 2,0 mm	180-354-01
Ø 0 / 4,0 mm	180-354-03
Ø 0 / 6,0 mm	180-354-05
Ø 0 / 8,0 mm	180-354-07
Ø 9,0 / 10,0 mm	180-354-09
Ø 11,0 / 12,0 mm	180-354-11
Ø 13,0 / 14,0 mm	180-354-13
Ø 15,0 / 16,0 mm	180-354-15
Ø 17,0 / 18,0 mm	180-354-17
Ø 19,0 / 20,0 mm	180-354-19
Ø 21,0 / 22,0 mm	180-354-21
Ø 23,0 / 24,0 mm	180-354-23
Ø 25,0 / 26,0 mm	180-354-25



HEGAR
 180-354-98
 Satz, Set, Juego, Set
 Ø 3,0 / 4,0 - Ø 17,0 / 18,0 mm
 (8 dilators)

HEGAR
 180-354-99
 Satz, Set, Juego, Set
 Ø 1,0 / 2,0 - Ø 25,0 / 26,0 mm
 (13 dilators)



HANK

Ø 4,5 / 15,0 mm	180-360-05
Ø 5,5 / 16,0 mm	180-360-06
Ø 6,5 / 17,0 mm	180-360-07
Ø 7,5 / 18,0 mm	180-360-08
Ø 8,5 / 19,0 mm	180-360-09
Ø 9,5 / 10,0 mm	180-360-10

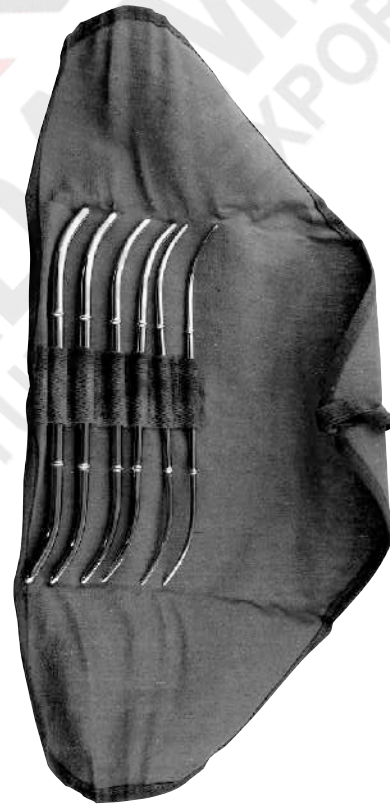

HANK
 180-360-98
 Satz, Set, Juego, Set
 Ø 4,5 / 5,0 - Ø 9,5 / 10,0 mm
 (6 dilators)

SURGICAL INSTRUMENTS



PRATT

Ø5 /	5,0 mm	180-370-05
Ø5 /	6,0 mm	180-370-06
Ø5 /	8,0 mm	180-370-08
Ø5 /	9,0 mm	180-370-09
Ø	9,5 / 10,0 mm	180-370-10
Ø	11,5 / 12,0 mm	180-370-12
Ø	12,5 / 13,0 mm	180-370-13
Ø	13,5 / 14,0 mm	180-370-14

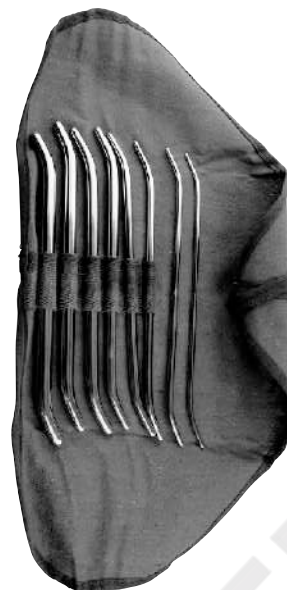

PRATT
180-370-98
Satz, Set, Juego, Set
Ø 4,5 / 5,0 - Ø 13,5 / 14,0 mm
(8 dilators)



BARRETT
18,0 cm, 7"
180-410-18



ADAIR
19,0 cm, 7 1/4"
180-412-19



STAUDE-MOORE
17,0 cm, 6 3/4"
180-414-17



JARCHO
20,0 cm, 8"
180-417-20



SCHROEDER
25,0 cm, 9 / $\frac{3}{4}$ 4
180-400-25



BRAUN
25,0 cm, 9 / $\frac{3}{4}$ 4
180-404-25



DUPLAY
28,0 cm, 11"
180-419-28



POZZI
26,0 cm, 10 / $\frac{1}{4}$ 4
180-402-26



KAHN
24,0 cm, 9 / $\frac{1}{4}$ 2
180-421-24

SURGICAL INSTRUMENTS



SKENE
24,0 cm, 9 / $\frac{1}{4}$ 2
180-423-24



SCHROEDER
24,0 cm, 9 / $\frac{1}{4}$ 2
180-426-24



SCHROEDER
24,0 cm, 9 / $\frac{1}{4}$ 2
180-429-24



TEALE
23,0 cm, 9"
180-431-23



JACOBS
21,0 cm, 8 / $\frac{1}{4}$ 2
180-434-21



JACOBS
21,0 cm, 8 / $\frac{1}{4}$ 2
180-435-21



MUSEUX
 24,0 cm, 9 / $\frac{1}{2}$

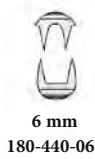

6 mm
 180-440-06



8 mm
 180-440-08



10 mm
 180-440-10



MUSEUX
 24,0 cm, 9 / $\frac{1}{2}$



6 mm
 180-441-06



8 mm
 180-441-08



10 mm
 180-441-10



BRAUN
 15,5 cm, 6"
 180-442-15



CZERNY
 20,5 cm, 8"
 180-444-20



PRATT
 28,0 cm, 11"
 180-446-28



IOWA
 26,0 cm, 10 / $\frac{1}{4}$
 180-449-26

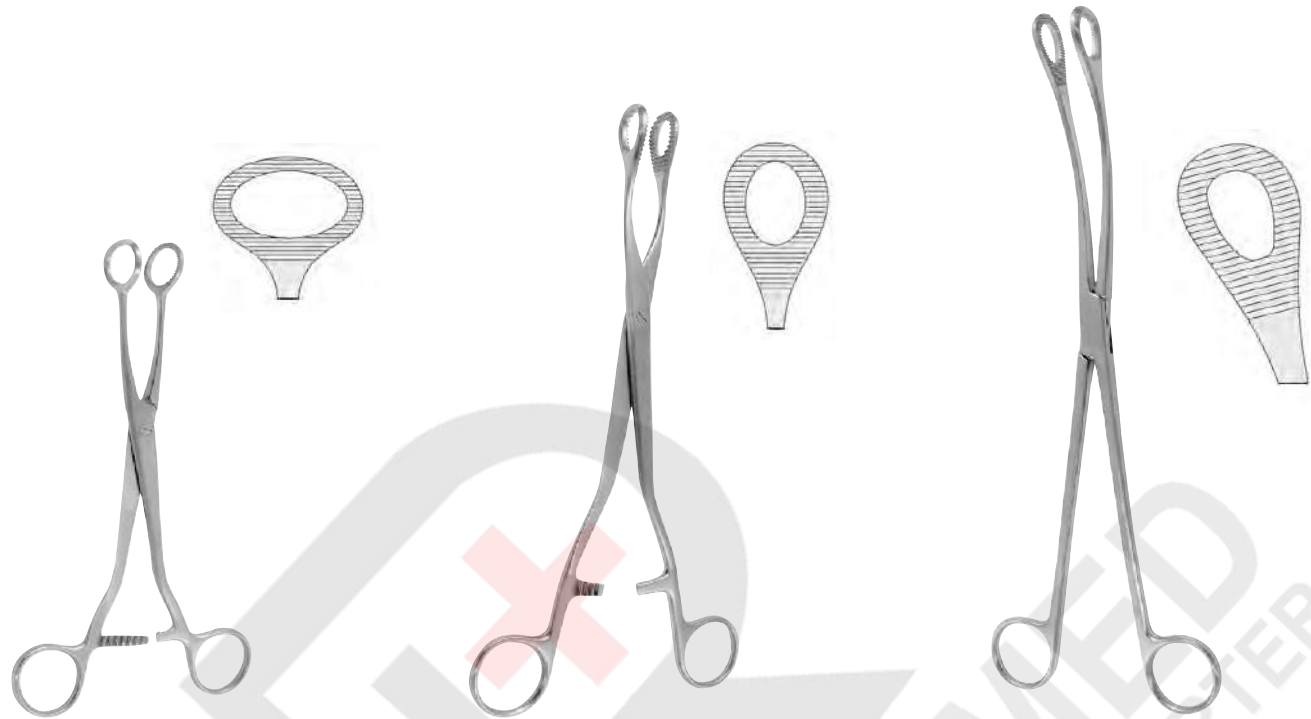

DOYEN
20,5 cm, 8"
180-470-20

NOTO
27,0 cm, 10" / $\frac{5}{8}$
180-472-27

KELLY
32,0 cm, 12" / $\frac{1}{2}$ 2
180-475-32



HEYWOOD-SMITH $\frac{3}{4}$
25,0 cm, 9" / 4
180-480-25

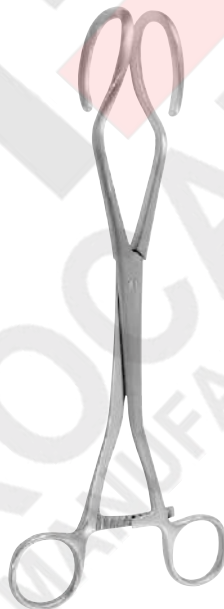

DARTIGUES $\frac{3}{4}$
27,0 cm, 10" / 4
180-482-27



SOMER
23,0 cm, 9"
180-485-23

SURGICAL INSTRUMENTS

Uterusfaßzangen, Uterussonden
 Zentimetereinteilung Uterine Elevating
 Forceps, Uterine Probes, graduated in
 Centimeters Pinzas para la útero
 Histerómetros, graduado en Centímetros
 Pinze per affarrare l'utero, Isterometri
 Graduato in cm



COLLIN
 25,0 cm, 9 / $\frac{3}{4}$ 4
 180-488-25



Amniotom
 Amniotome
 Amniótomo
 Amniotomo

BEACHAM
 26,0 cm, 10 / $\frac{1}{4}$ 4
 180-500-26



Uterus-Depressor
 Uterine depressor
 Depresor uterino
 Depressori uterini

BRAUN
 28,0 cm, 11"
 180-502-28



SIMS
 32,0 cm, 12
 180-510-32

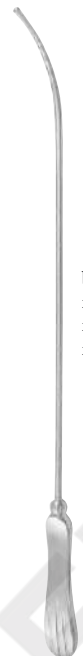

biegsam
 malleable
 maleable
 malleabile

SIMS
 32,0 cm, 12 / $\frac{1}{4}$ 2
 180-511-32



MARTIN
 32,0 cm, 12 / $\frac{1}{4}$ 2
 180-516-32

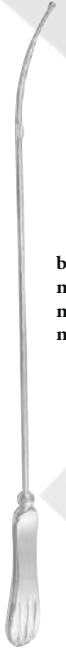

biegsam
 malleable
 maleable
 malleabile

MARTIN
 32,0 cm, 12 / $\frac{1}{4}$ 2
 180-518-32



VALLEIX
 25,0 cm, 10"
 180-521-25

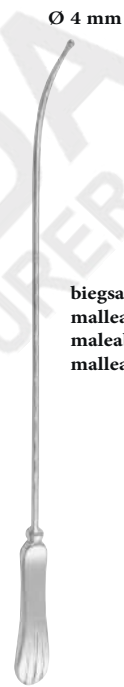

Ø 4 mm

biegsam
 malleable
 maleable
 malleabile

SIMPSON
 29,0 cm, 11 / $\frac{1}{4}$ 2
 180-527-29



Ø 4 mm

COLLIN
 28,0 cm, 11"
 180-529-28

SURGICAL INSTRUMENTS



KEVORKIAN
30,0 cm, 12"
180-540-30



KEVORKIAN
30,0 cm, 12"
180-542-30



KEVORKIAN
30,0 cm, 12"
180-543-30



NOVAK
23,0 cm, 9"
180-550-04



RANDALL
23,0 cm, 9"
180-552-04



MILAN
29,0 cm, 11 / 1 2

Ø 4 mm
180-560-04

Ø 6 mm
180-560-06

Ø 9 mm
180-560-09

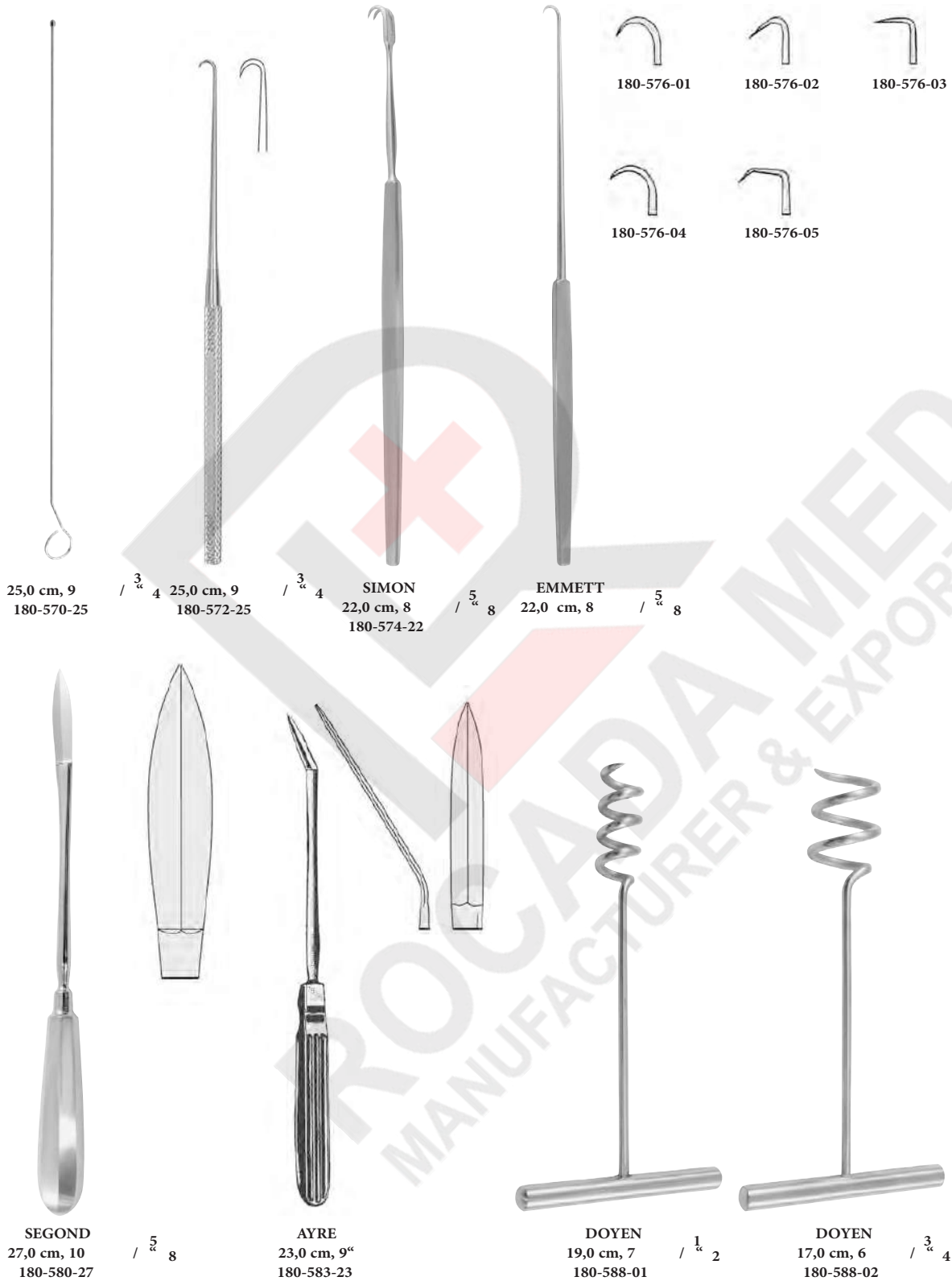

SURGICAL INSTRUMENTS

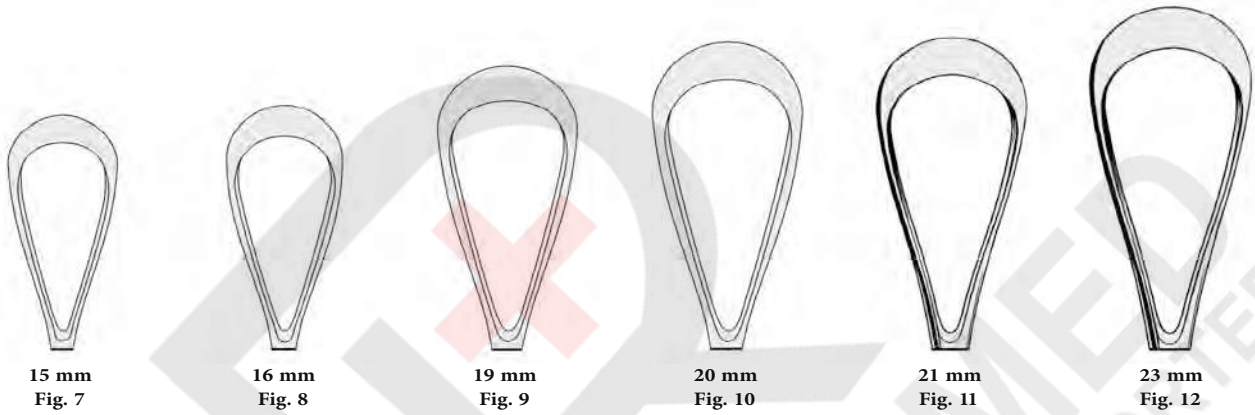
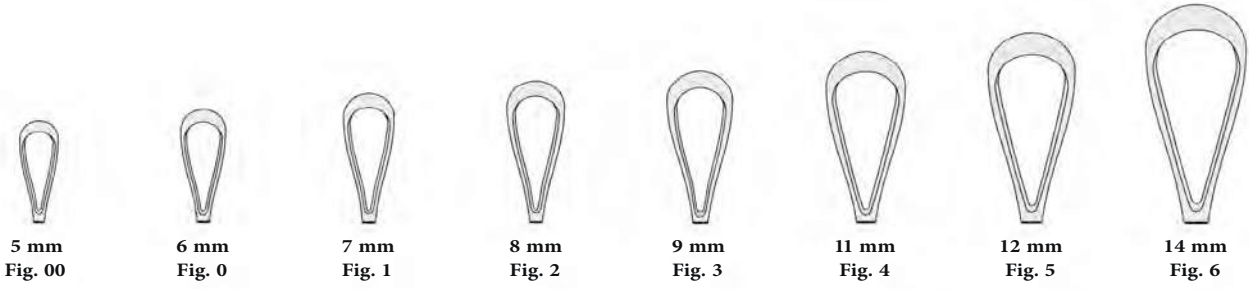

SURGICAL INSTRUMENTS



RECAMIER
26,0 cm, 10

scharf, fest
sharp, rigid
cortantes, rígidas
acute, rigide

Fig. 00	180-700-05
Fig. 00	180-700-06
Fig. 01	180-700-07
Fig. 02	180-700-08
Fig. 03	180-700-09
Fig. 04	180-700-11
Fig. 05	180-700-12
Fig. 06	180-700-14
Fig. 07	180-700-15
Fig. 08	180-700-16
Fig. 09	180-700-19
Fig. 10	180-700-20
Fig. 11	180-700-21
Fig. 12	180-700-23

/ $\frac{1}{4}$



RECAMIER
26,0 cm, 10

scharf, biegsam
sharp, malleable
cortantes, maleable
acute, malleabile

Fig. 00	180-701-05
Fig. 00	180-701-06
Fig. 01	180-701-07
Fig. 02	180-701-08
Fig. 03	180-701-09
Fig. 04	180-701-11
Fig. 05	180-701-12
Fig. 06	180-701-14
Fig. 07	180-701-15
Fig. 08	180-701-16
Fig. 09	180-701-19
Fig. 10	180-701-20
Fig. 11	180-701-21
Fig. 12	180-701-23

/ $\frac{1}{4}$

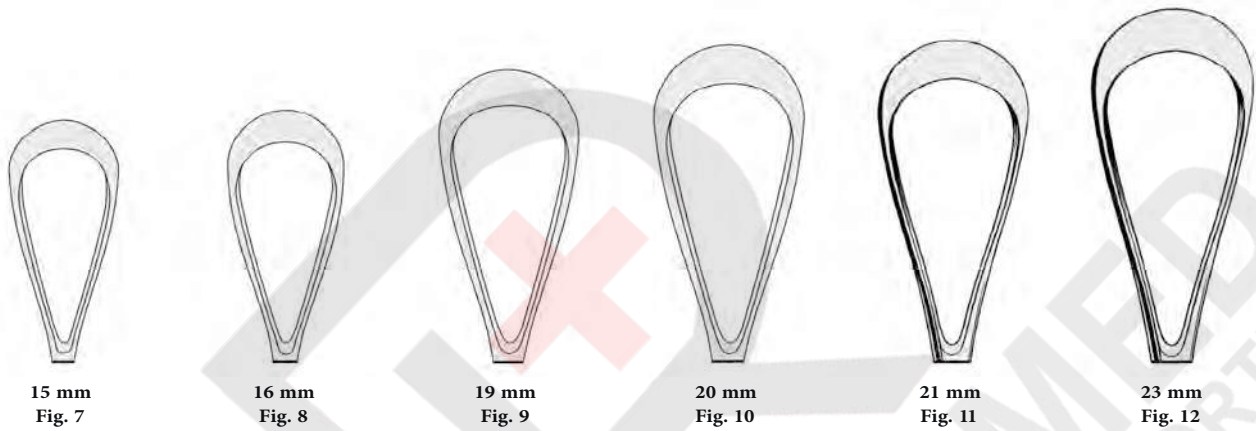
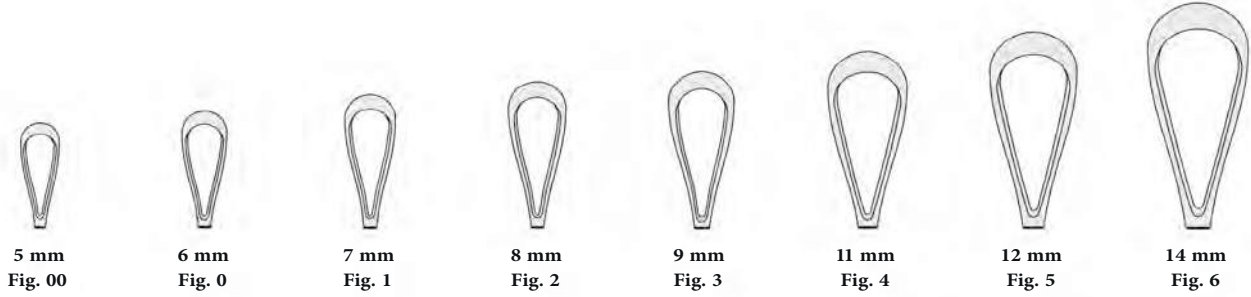

scharf, fest
 sharp, rigid
 cortantes, rígidas
 acute, rigide

Fig. 00	180-702-05
Fig. 01	180-702-06
Fig. 02	180-702-07
Fig. 03	180-702-08
Fig. 04	180-702-09
Fig. 05	180-702-11
Fig. 06	180-702-12
Fig. 07	180-702-14
Fig. 08	180-702-15
Fig. 09	180-702-16
Fig. 10	180-702-19
Fig. 11	180-702-20
Fig. 12	180-702-21
Fig. 13	180-702-23

SIMS
 26,0 cm, 10

/ ¼ 4



scharf, biegsam
 sharp, malleable
 cortantes, maleable
 acute, malleabile

Fig. 00	180-703-05
Fig. 01	180-703-06
Fig. 02	180-703-07
Fig. 03	180-703-08
Fig. 04	180-703-09
Fig. 05	180-703-11
Fig. 06	180-703-12
Fig. 07	180-703-14
Fig. 08	180-703-15
Fig. 09	180-703-16
Fig. 10	180-703-19
Fig. 11	180-703-20
Fig. 12	180-703-21
Fig. 13	180-703-23

SIMS
 26,0 cm, 10

/ ¼ 4

SURGICAL INSTRUMENTS

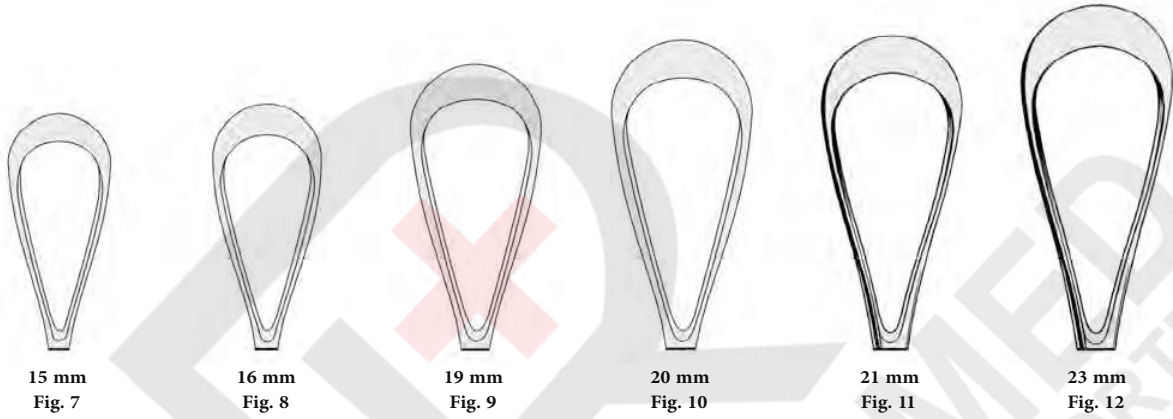
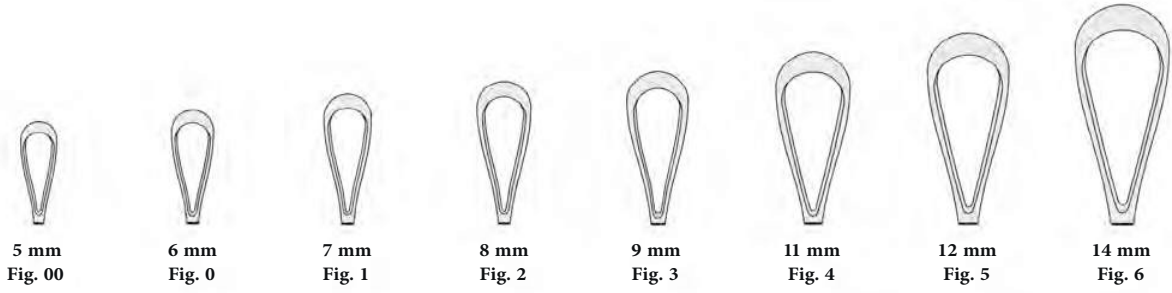

scharf, fest
sharp, rigid
cortantes, rígidas
acute, rigide

scharf, biegsam
sharp, malleable
cortantes, maleable
acute, malleabile

Fig. 00	180-710-05
Fig. 0 0	180-710-06
Fig. 0 1	180-710-07
Fig. 0 2	180-710-08
Fig. 0 3	180-710-09
Fig. 0 4	180-710-11
Fig. 0 5	180-710-12
Fig. 0 6	180-710-14
Fig. 0 7	180-710-15
Fig. 0 8	180-710-16
Fig. 0 9	180-710-19
Fig. 10	180-710-20
Fig. 11	180-710-21
Fig. 12	180-710-23

Fig. 00	180-711-05
Fig. 0 0	180-711-06
Fig. 0 1	180-711-07
Fig. 0 2	180-711-08
Fig. 0 3	180-711-09
Fig. 0 4	180-711-11
Fig. 0 5	180-711-12
Fig. 0 6	180-711-14
Fig. 0 7	180-711-15
Fig. 0 8	180-711-16
Fig. 0 9	180-711-19
Fig. 10	180-711-20
Fig. 11	180-711-21
Fig. 12	180-711-23



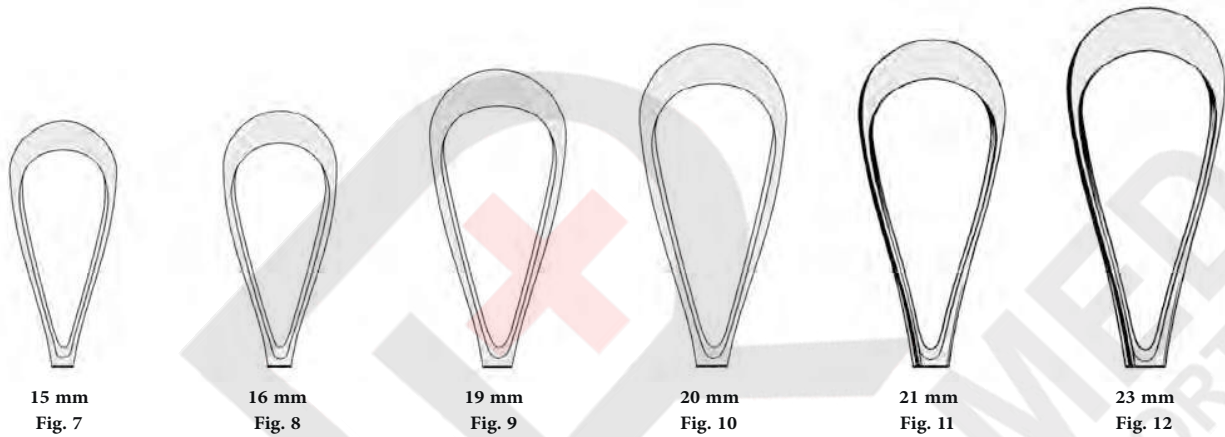
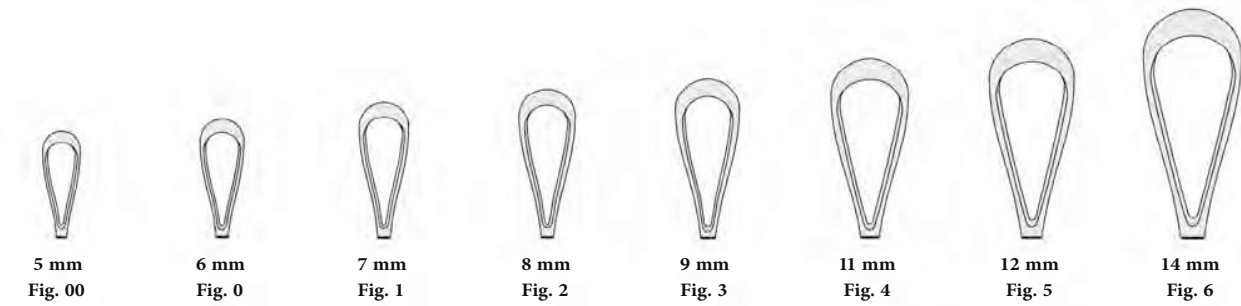

scharf, fest
 sharp, rigid
 cortantes, rígidas
 acute, rigide

scharf, biegsam
 sharp, malleable
 cortantes, maleable
 acute, malleabile



SIMS
 31,0 cm, 12

Fig. 00	180-712-05
Fig. 00	180-712-06
Fig. 01	180-712-07
Fig. 02	180-712-08
Fig. 03	180-712-09
Fig. 04	180-712-11
Fig. 05	180-712-12
Fig. 06	180-712-14
Fig. 07	180-712-15
Fig. 08	180-712-16
Fig. 09	180-712-19
Fig. 10	180-712-20
Fig. 11	180-712-21
Fig. 12	180-712-23

/ $\frac{1}{4}$



SIMS
 31,0 cm, 12

Fig. 00	180-713-05
Fig. 00	180-713-06
Fig. 01	180-713-07
Fig. 02	180-713-08
Fig. 03	180-713-09
Fig. 04	180-713-11
Fig. 05	180-713-12
Fig. 06	180-713-14
Fig. 07	180-713-15
Fig. 08	180-713-16
Fig. 09	180-713-19
Fig. 10	180-713-20
Fig. 11	180-713-21
Fig. 12	180-713-23

/ $\frac{1}{4}$

SURGICAL INSTRUMENTS



30 mm
Fig. 1

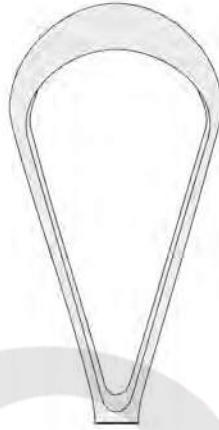

35 mm
Fig. 2

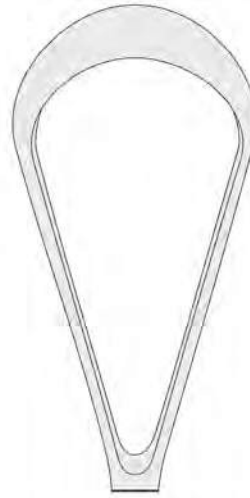

40 mm
Fig. 3



scharf, fest
sharp, rigid
cortantes, rígidas
acute, rigide

Fig. 01	180-720-30
Fig. 02	180-720-35
Fig. 03	180-720-40

SIMS
31,0 cm, 12 / $\frac{1}{4}$ 4



scharf, biegsam
sharp, malleable
cortantes, maleable
acute, malleabile

Fig. 01	180-721-30
Fig. 02	180-721-35
Fig. 03	180-721-40

SIMS
31,0 cm, 12 / $\frac{1}{4}$ 4



30 mm
 Fig. 1

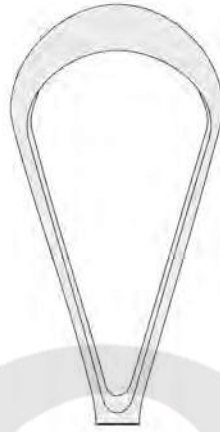

35 mm
 Fig. 2

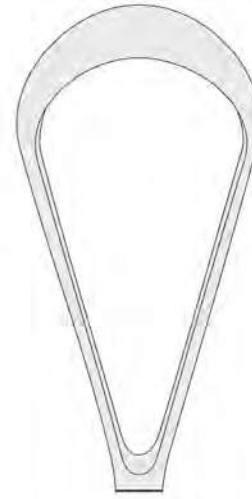

40 mm
 Fig. 3



BUMM
 31,0 cm, 12 / $\frac{1}{4}$ 4

scharf, fest
 sharp, rigid
 cortantes, rígidas
 acute, rigide

Fig. 01	180-722-30
Fig. 02	180-722-35
Fig. 03	180-722-40



BUMM
 31,0 cm, 12 / $\frac{1}{4}$ 4

scharf, biegsam
 sharp, malleable
 cortantes, maleable
 acute, malleabile

Fig. 01	180-723-30
Fig. 02	180-723-35
Fig. 03	180-723-40

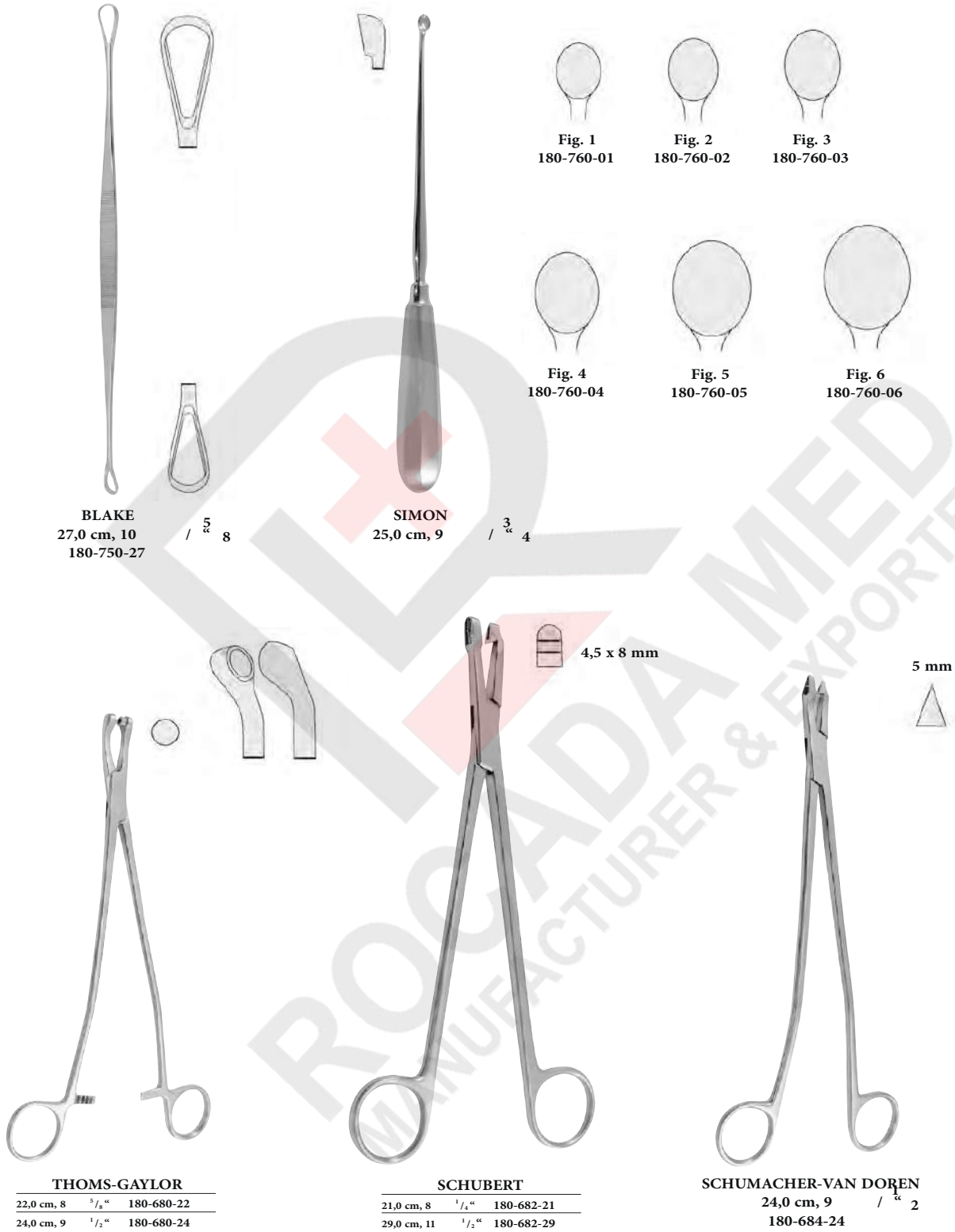

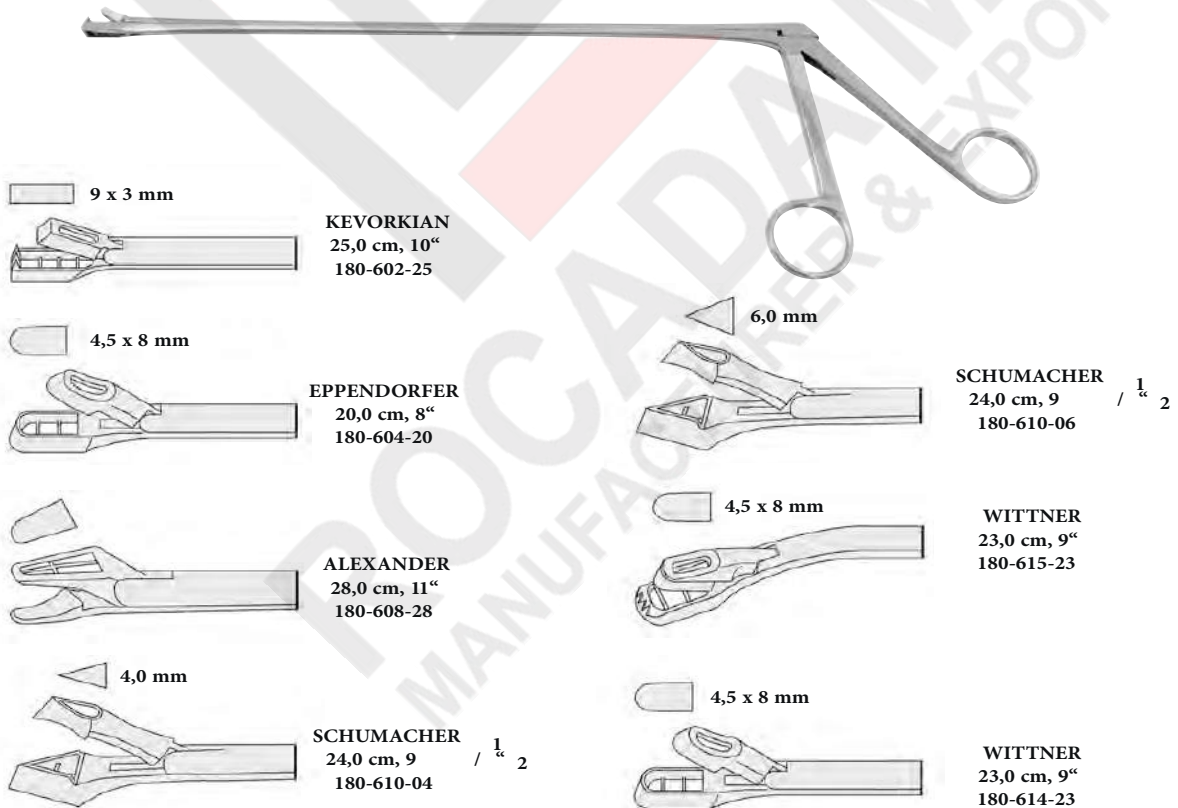
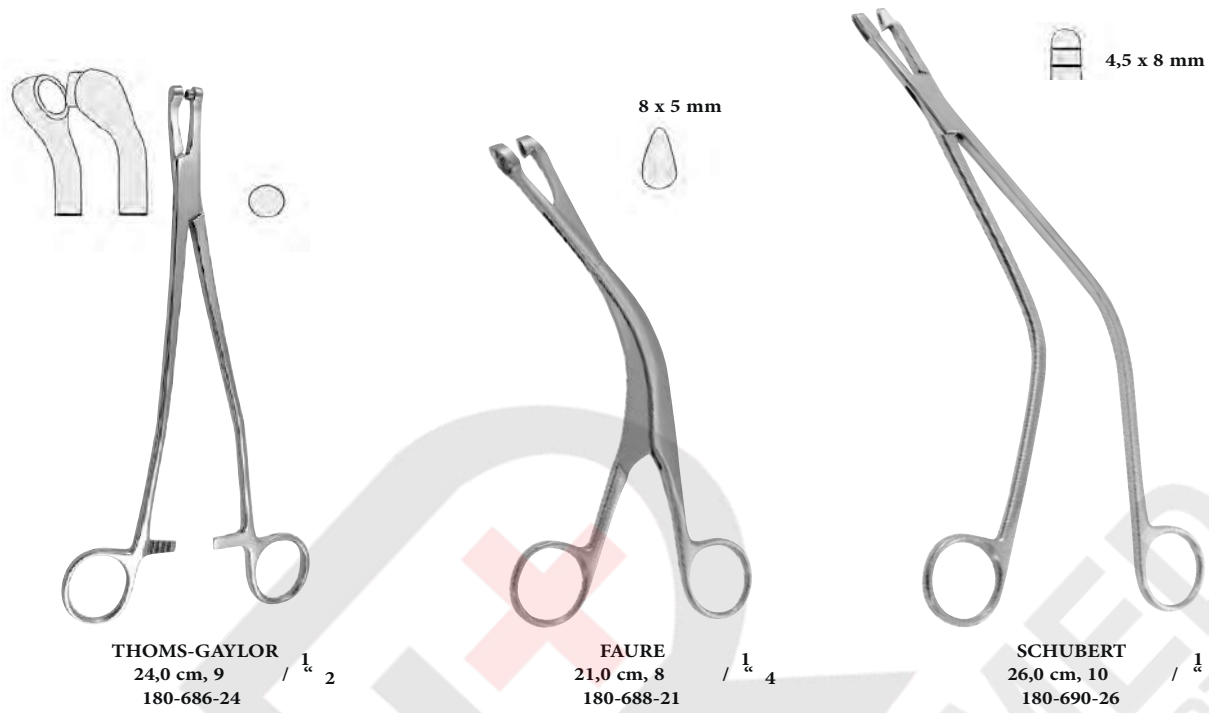

SURGICAL INSTRUMENTS

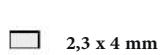
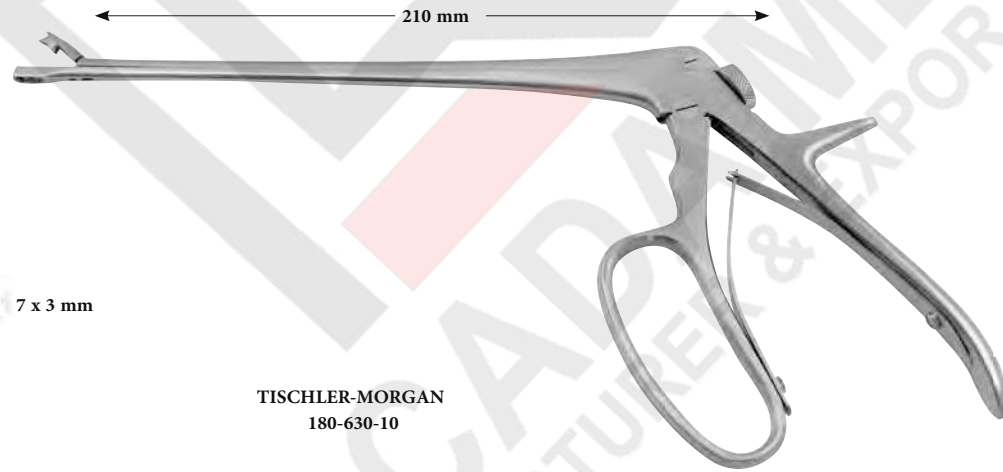
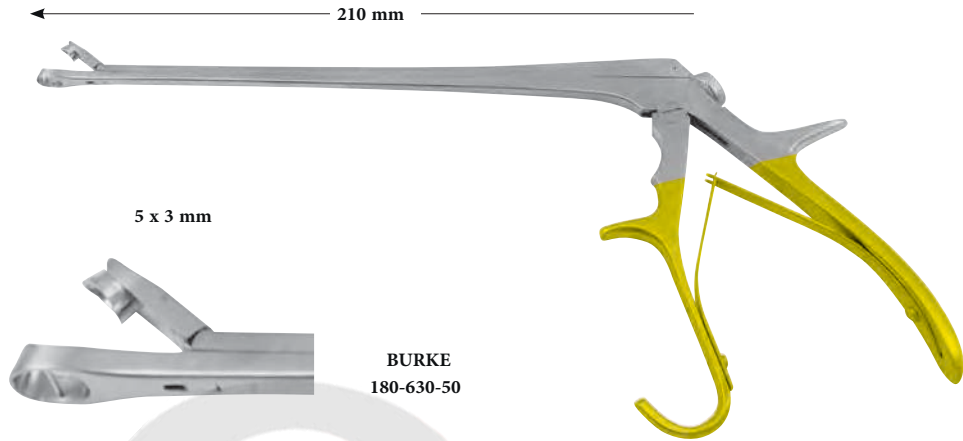

MINI-TOWNSEND
180-630-12



TISCHLER-KEVORKIAN
180-630-41

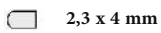

BABY-TISCHLER
180-630-14



KEVORKIAN-PACIFIC
180-630-40



WRIGLEY
28,0 cm, 11"
181-056-28

SIMPSON
30,0 cm, 11" / $\frac{3}{4}$ " 4

SIMPSON-BRAUN
33,0 cm, 13"
181-036-33

SIMPSON-BRAUN
36,0 cm, 14" / $\frac{1}{8}$ " 8

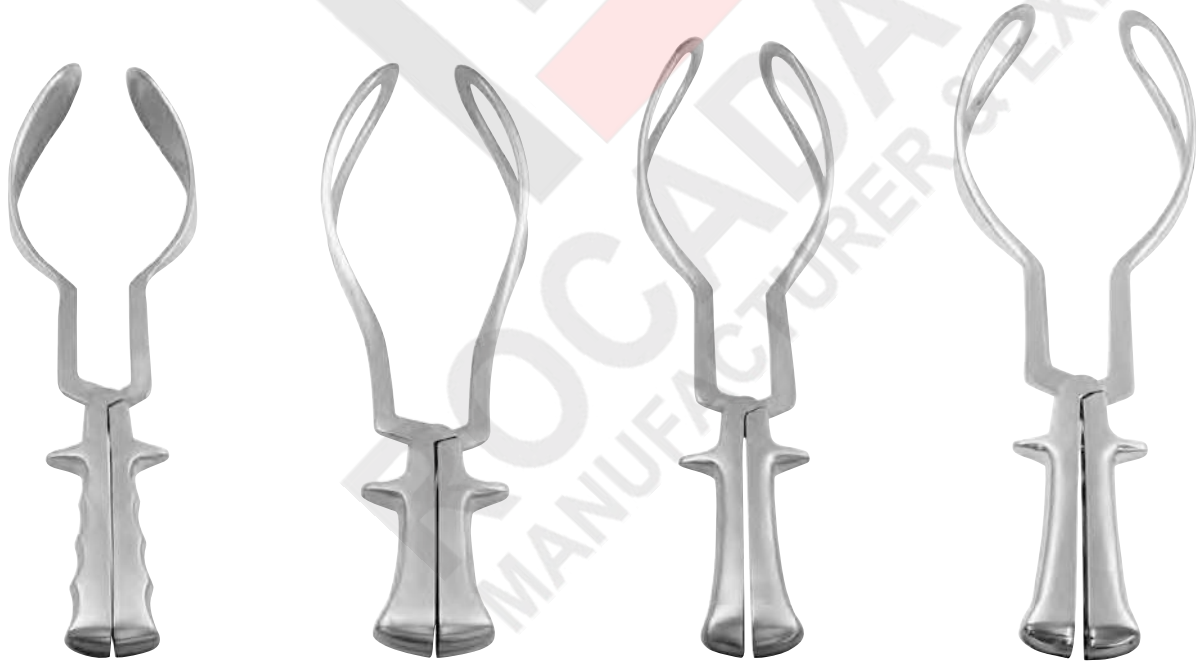

SIMPSON-LUIKART
36,0 cm, 14" / $\frac{1}{8}$ " 8
181-046-36

DE LEE
30,0 cm, 11" / $\frac{3}{4}$ " 4
181-058-30

DE LEE
36,0 cm, 14" / $\frac{1}{8}$ " 8
181-058-36

DE LEE
38,0 cm, 15" / $\frac{3}{8}$ " 8
181-058-38

SURGICAL INSTRUMENTS

SURGICAL INSTRUMENTS



MC LEAN
36,0 cm, 14 / $\frac{1}{4}$ 8
181-044-36



KIELAND
41,0 cm, 16"
181-052-41



KIELAND-LUIKART
40,0 cm, 15 / $\frac{3}{4}$ 4
181-054-40



PIPER
44,0 cm, 17 / $\frac{1}{4}$ 4
181-060-44



ELLIOT
32,0 cm, 12 / $\frac{1}{2}$ 2
181-080-32



ELLIOT
38,0 cm, 15"
181-080-38



NAEGELE
36,0 cm, 14 / $\frac{1}{4}$ 8
181-084-36



NAEGELE
40,0 cm, 15 / $\frac{3}{4}$ 4
181-084-40

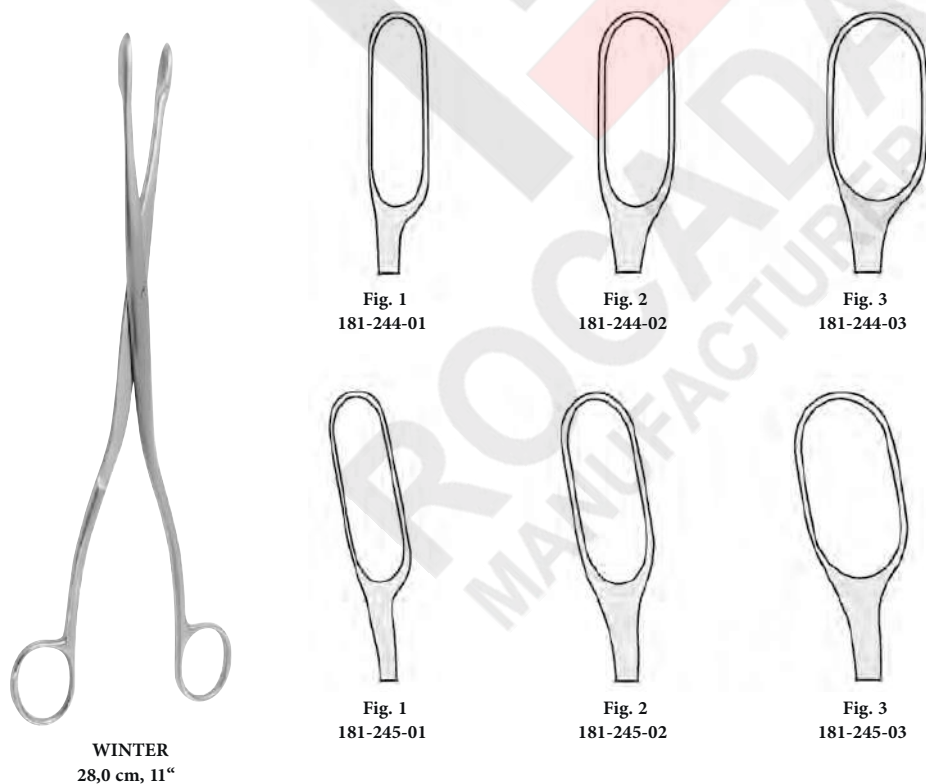
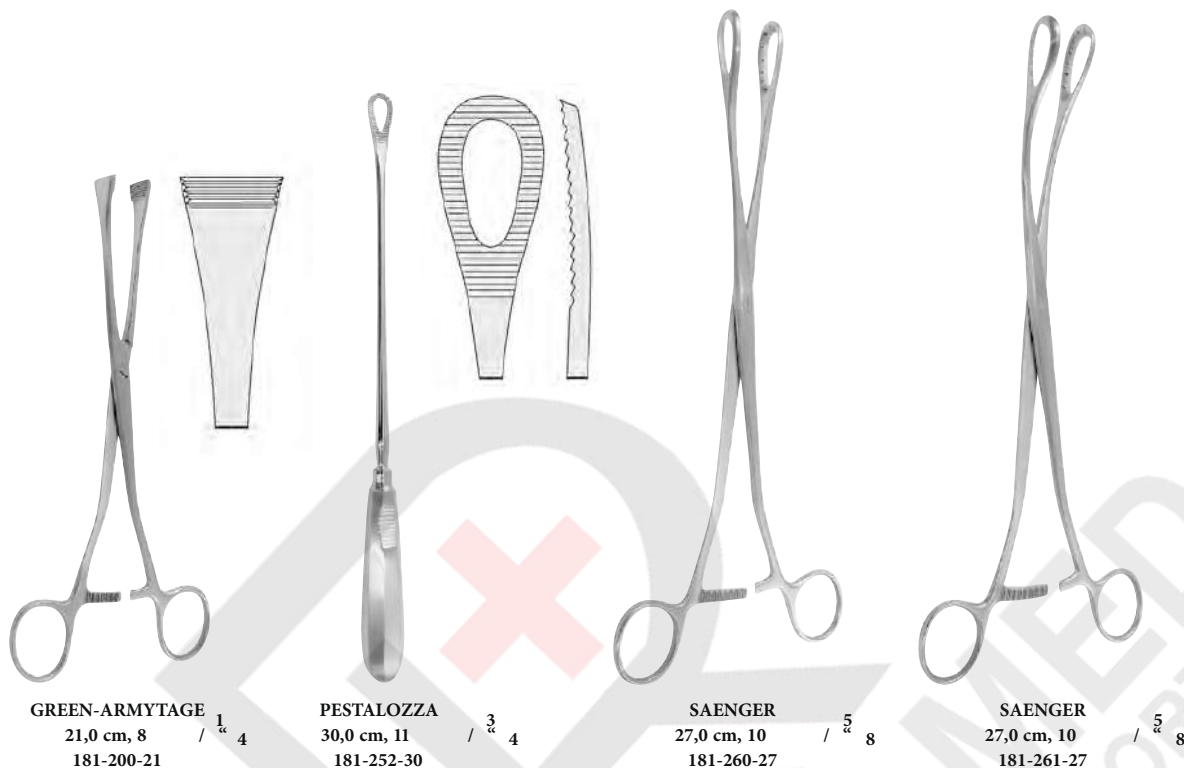

SURGICAL INSTRUMENTS



WALLICH
42,0 cm, 16
181-300-42 / 1 2



MARTIN
34,0 cm, 13
181-600-34 / 3 8



gerade
straight
recto
retto

BIERER
33,0 cm, 13"
58-1236-01



gerade
straight
recto
retto

BIERER
33,0 cm, 13"
181-236-02



gebogen
curved
curvo
curvo

BIERER
33,0 cm, 13"
181-237-01



gebogen
curved
curvo
curvo

BIERER
33,0 cm, 13"
181-237-02

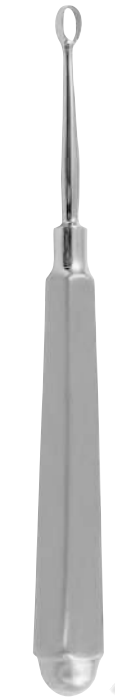

Lupusküretten
 Lupus curettes
 Curetas para lupus
 Raschiatoio per lupus



3 mm
 186-110-03



4 mm
 186-110-04



5 mm
 186-110-05

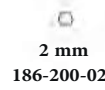

2 mm
 186-200-02



3 mm
 186-200-03



4 mm
 186-200-04

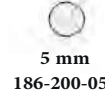

5 mm
 186-200-05



6 mm
 186-200-06



7 mm
 186-200-07



8 mm
 186-200-08



KEYES
 12,0 cm, 4 / $\frac{3}{4}$

PIFFARD
 14,0 cm, 5 / $\frac{3}{4}$

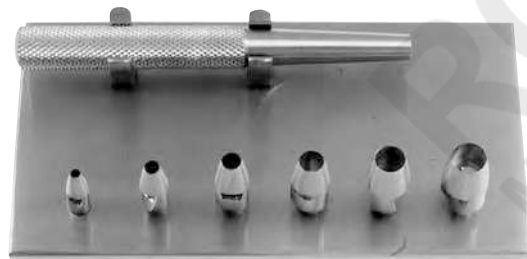

KEYES
 12,0 cm, 4 / $\frac{3}{4}$
 186-210-00

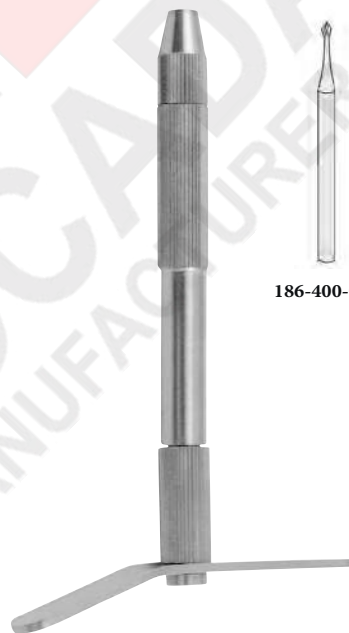

186-400-00
 komplett, complete,
 completo, completo,



186-400-01



186-400-02



186-400-03

SURGICAL INSTRUMENTS

SURGICAL INSTRUMENTS



UNNA
14,0 cm, 5 / 3/4 4
186-000-14



UNNA
14,0 cm, 5 / 3/4 4
186-002-14



SAALFELD
10,0 cm, 4"
186-010-10



SAALFELD
14,0 cm, 5 / 3/4 4
186-012-14



SCHAMBERG
10,0 cm, 4"
186-020-10



WALTON
14,0 cm, 5 / 3/4 4
186-030-14



FOX
14,0 cm, 5 / 3/4 4



3 mm
186-100-03



4 mm
186-100-04



5 mm
186-100-05



6 mm
186-110-06

Lupusküretten
Lupus curettes
Curetas para lupus
Raschiatoio per lupus



186-420-01

17,0 cm, 6 / $\frac{3}{8}$ 4
186-420-17



186-430-01

WALTON
16,0 cm, 6 / $\frac{1}{4}$ 4
186-430-16



RADOLF
13,5 cm, 5 / $\frac{3}{8}$ 8
186-500-13



13,5 cm, 5 / $\frac{3}{8}$ 8
186-510-13



13,0 cm, 5"
186-600-13



186-610-01

186-610-02

14,0 cm, 5 / $\frac{1}{4}$ 2

SURGICAL INSTRUMENTS

SURGICAL INSTRUMENTS



SCHEDE
17,0 cm, 6

/ $\frac{3}{4}$

Fig. 4
192-467-14



VOLKMANN
17,0 cm, 6

/ $\frac{3}{4}$

Fig. 6
192-469-16

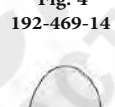
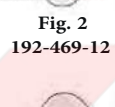

BRUNS
17,0 cm, 6

/ $\frac{3}{4}$

Fig. 6
192-472-16

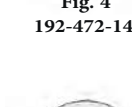
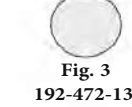
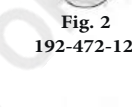
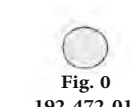
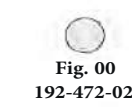

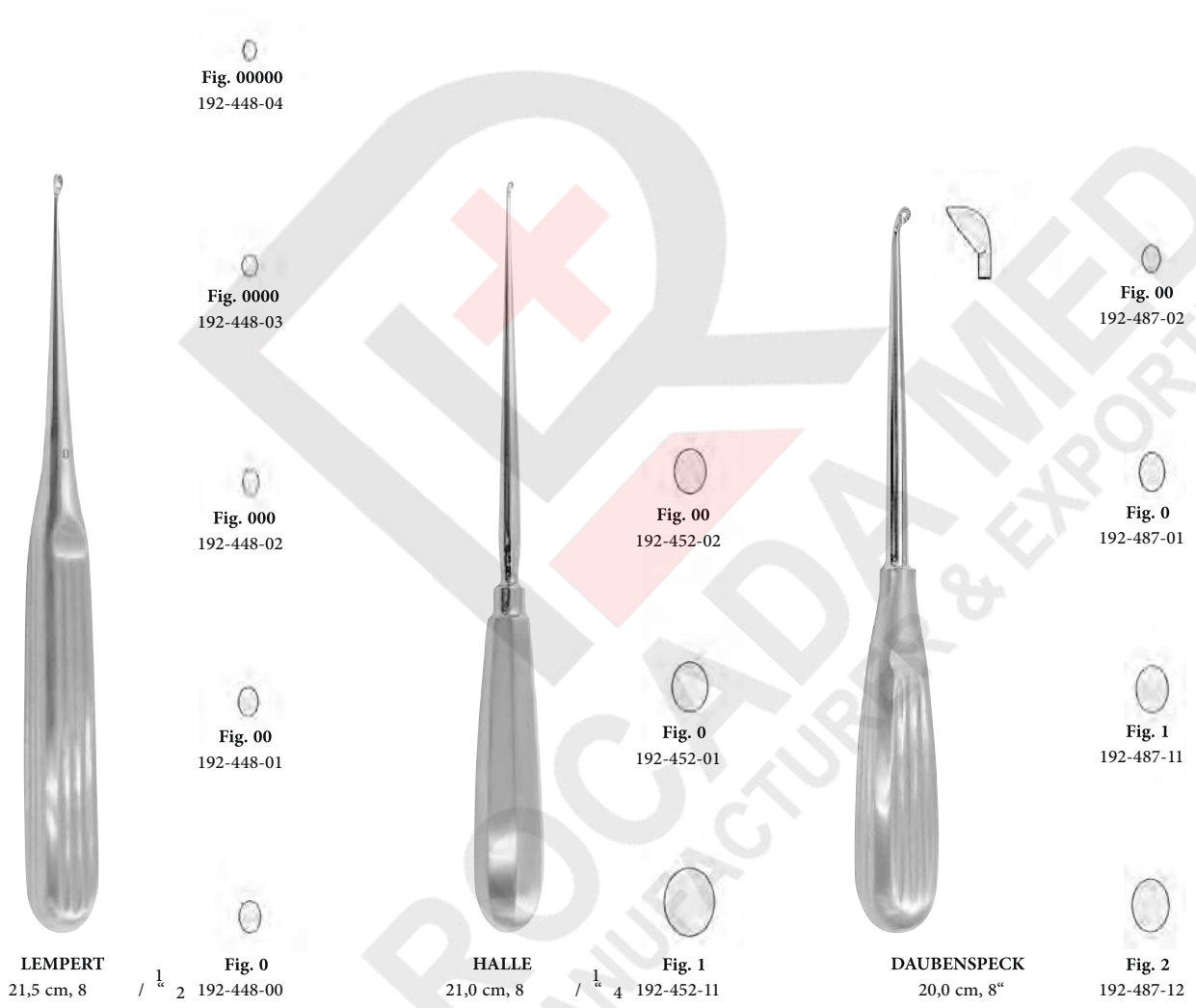

SURGICAL INSTRUMENTS

SURGICAL INSTRUMENTS

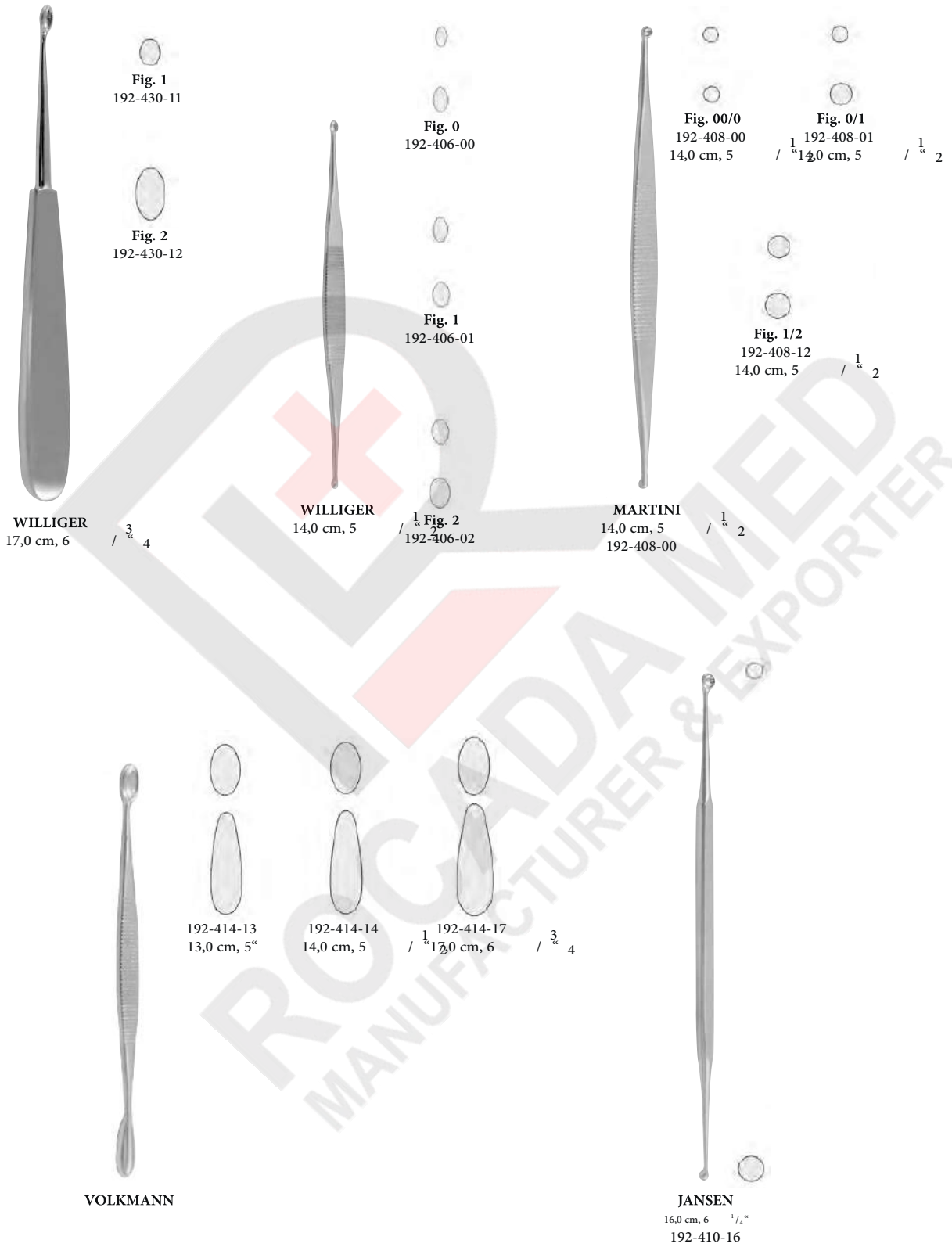

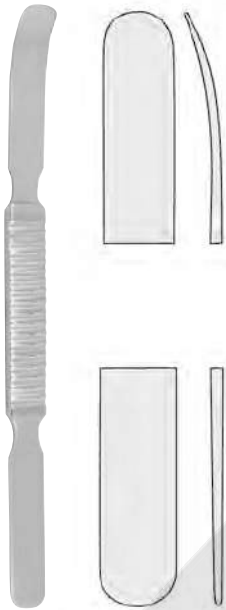

WATSON-CHEYNE
17,5 cm, 6 / $\frac{5}{8}$
193-501-17



MC DONALD
19,0 cm, 7 / $\frac{1}{2}$
193-440-19



WILLIGER
17,0 cm, 6 / $\frac{3}{4}$
193-512-17



WILLIGER
16,0 cm, 6 / $\frac{1}{4}$
193-512-16

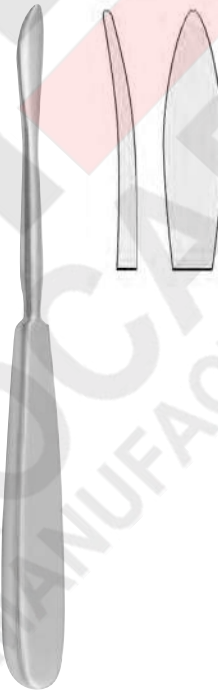

LANGENBECK
20,0 cm, 8"
193-520-08

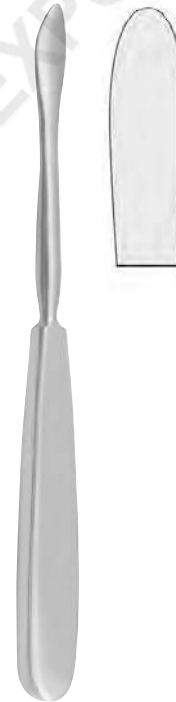

LANGENBECK
20,0 cm, 8"
193-520-10

SURGICAL INSTRUMENTS

SURGICAL INSTRUMENTS



ADSON
17,0 cm, 6



8 mm
193-465-01

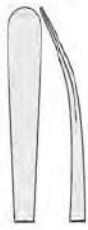

7 mm
193-465-02



7 mm
193-465-03



7 mm
193-465-04



KÖNIG
15,5 cm, 6"
193-476-15

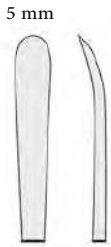

5 mm



LAMBOTTE
21,0 cm, 8 / $\frac{1}{4}$



10 mm
193-477-10



15 mm
193-477-15



20 mm
193-477-20



25 mm
193-477-25



FARABEUF
15,0 cm, 6"
193-478-15



12,5 mm



SURGICAL INSTRUMENTS

SURGICAL INSTRUMENTS

1,8,0 mm	194-300-08	1,8,0 mm	194-301-08	1,8,0 mm	194-302-08
10,0 mm	194-300-10	10,0 mm	194-301-10	10,0 mm	194-302-10
12,0 mm	194-300-12	12,0 mm	194-301-12	12,0 mm	194-302-12
14,0 mm	194-300-14	14,0 mm	194-301-14	14,0 mm	194-302-14
16,0 mm	194-300-16	16,0 mm	194-301-16	16,0 mm	194-302-16

13,5 cm, 5 ³/₈"

3,0 mm	194-334-03	3,0 mm	194-336-03	10,0 mm	194-361-10
4,0 mm	194-334-04	4,0 mm	194-336-04	15,0 mm	194-361-15
5,0 mm	194-334-05	5,0 mm	194-336-05	20,0 mm	194-361-20
6,0 mm	194-334-06	6,0 mm	194-336-06	25,0 mm	194-361-25

PARTSCH 13,5 cm, 5 ³/₈"

PARTSCH 13,5 cm, 5 ³/₈"

STILLE 20,0 cm, 8"



10,0 mm	194-360-10
15,0 mm	194-360-15
20,0 mm	194-360-20
25,0 mm	194-360-25

STILLE
 20,0 cm, 8"



10,0 mm	194-362-10
15,0 mm	194-362-15
20,0 mm	194-362-20
25,0 mm	194-362-25

STILLE
 20,0 cm, 8"



14,0 mm	194-318-04
16,0 mm	194-318-06
18,0 mm	194-318-08
10,0 mm	194-318-10
12,0 mm	194-318-12
14,0 mm	194-318-14

ALEXANDER
 18,0 cm, 7"



14,0 mm	194-319-04
16,0 mm	194-319-06
18,0 mm	194-319-08
10,0 mm	194-319-10
12,0 mm	194-319-12
14,0 mm	194-319-14

ALEXANDER
 18,0 cm, 7"



16,0 mm	194-350-06
19,0 mm	194-350-09
13,0 mm	194-350-13
16,0 mm	194-350-16
19,0 mm	194-350-19
25,0 mm	194-350-25
32,0 mm	194-350-32

SMITH-PETERSEN
 20,0 cm, 8"



16,0 mm	194-351-06
19,0 mm	194-351-09
13,0 mm	194-351-13
16,0 mm	194-351-16
19,0 mm	194-351-19
25,0 mm	194-351-25
32,0 mm	194-351-32

SMITH-PETERSEN
 20,0 cm, 8"

SURGICAL INSTRUMENTS



19,0 mm	194-352-09
14,0 mm	194-352-14
16,0 mm	194-352-16
19,0 mm	194-352-19
25,0 mm	194-352-25

SMITH-PETERSEN
20,0 cm, 8"



19,0 mm	194-353-09
14,0 mm	194-353-14
16,0 mm	194-353-16
19,0 mm	194-353-19
25,0 mm	194-353-25

SMITH-PETERSEN
20,0 cm, 8"



16,0 mm	194-450-06
15,0 mm	194-450-15
20,0 mm	194-450-20
25,0 mm	194-450-25
30,0 mm	194-450-30
38,0 mm	194-450-38
44,0 mm	194-450-44
50,0 mm	194-450-50

LAMBOTTE
24,0 cm, 9" / 1 1/2"

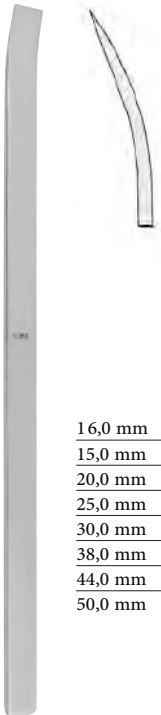

16,0 mm	194-451-06
15,0 mm	194-451-15
20,0 mm	194-451-20
25,0 mm	194-451-25
30,0 mm	194-451-30
38,0 mm	194-451-38
44,0 mm	194-451-44
50,0 mm	194-451-50

LAMBOTTE
24,0 cm, 9" / 1 1/2"

Ø 30 mm
220 g



COLLIN
20,0 cm, 8"
191-132-20

Ø 22 mm
200 g



PARTSCH
18,0 cm, 7"
191-145-18

mit Bleifüllung
lead filled head
cabezal relleno de plomo
testa di piombo

Ø 45 mm
300 g



BERGMANN
24,0 cm, 9" / 1 1/2"
191-201-24



20,0 cm, 8"
250-160-20



CHEATTLE
27,0 cm, 10" / $\frac{5}{8}$
250-163-27



ROGGE
23,0 cm, 9"
250-164-23



MAYO
14,0 cm, 5" / $\frac{1}{2}$
250-151-14



BUNT
12,0 cm, 4" / $\frac{3}{4}$
250-154-12

SURGICAL INSTRUMENTS

SURGICAL INSTRUMENTS



Ø 75 x 130 mm	250-142-06
Ø 75 x 175 mm	250-142-07
Ø 100 x 175 mm	250-142-08
Ø 100 x 200 mm	250-142-09



Ø 40,0 mm	250-130-04
Ø 60,0 mm	250-130-06
Ø 80,0 mm	250-130-08
Ø 100,0 mm	250-130-10
Ø 120,0 mm	250-130-12
Ø 150,0 mm	250-130-15



165 x 55 mm	10,75 l	250-133-00
175 x 70 mm	11,00 l	250-133-10
225 x 100 mm	12,00 l	250-133-20
240 x 95 mm	12,75 l	250-133-30
260 x 120 mm	14,00 l	250-133-40
290 x 100 mm	15,00 l	250-133-50
315 x 150 mm	15,50 l	250-133-60
325 x 135 mm	18,00 l	250-133-70
360 x 165 mm	12,00 l	250-133-80
415 x 150 mm	14,00 l	250-133-90



170 mm	250-140-17
250 mm	250-140-25
275 mm	250-140-27



250-300-00
Ø 65 x 17 mm
Außen- und Innendose
Exterior and interior box
Caja exterior e interior
Scatola esterna es interiore

250-300-01
Ø 62 x 13 mm
Innendose allein
Interior box only
Caja interior, suelta
Scatola interiore sola

200 x 150 x 25 mm	250-200-01
260 x 180 x 30 mm	250-200-02
300 x 220 x 30 mm	250-200-03
350 x 220 x 40 mm	250-200-04
220 x 170 x 50 mm	250-200-05
280 x 200 x 50 mm	250-200-06
320 x 240 x 50 mm	250-200-07
370 x 270 x 50 mm	250-200-08
420 x 320 x 50 mm	250-200-09



25 ccm
250-310-25



50 ccm
250-310-50

SURGICAL INSTRUMENTS



Bürstenspender für 10 Bürsten
Brush dispenser for 10 brushes
Distribuidor de cepillos para 10 cepillos
Distributore per 10 spazzole
260 x 155 x 65 mm
250-800-01

Bürstenspender für 20 Bürsten
Brush dispenser for 20 brushes
Distribuidor de cepillos para 20 cepillos
Distributore per 20 spazzole
270 x 240 x 65 mm
250-800-02

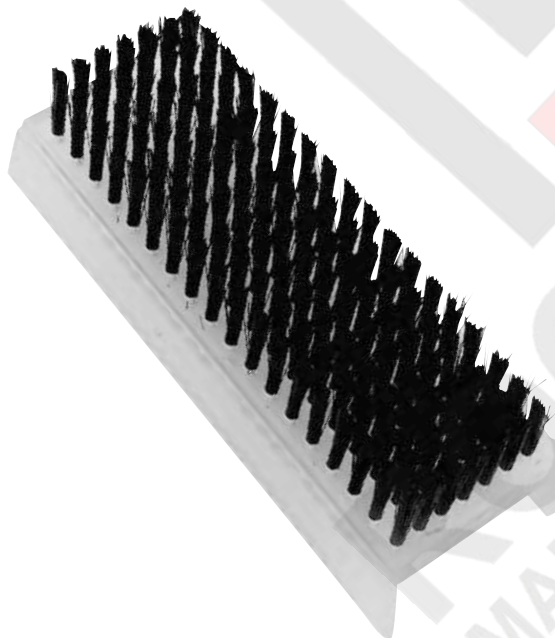

250-800-10

mehr als 400x autoklavierbar
more than 400 times autoclavable
esterilizable más de 400 veces en autoclave
sterilizzabile più di 400 volte in autoclave

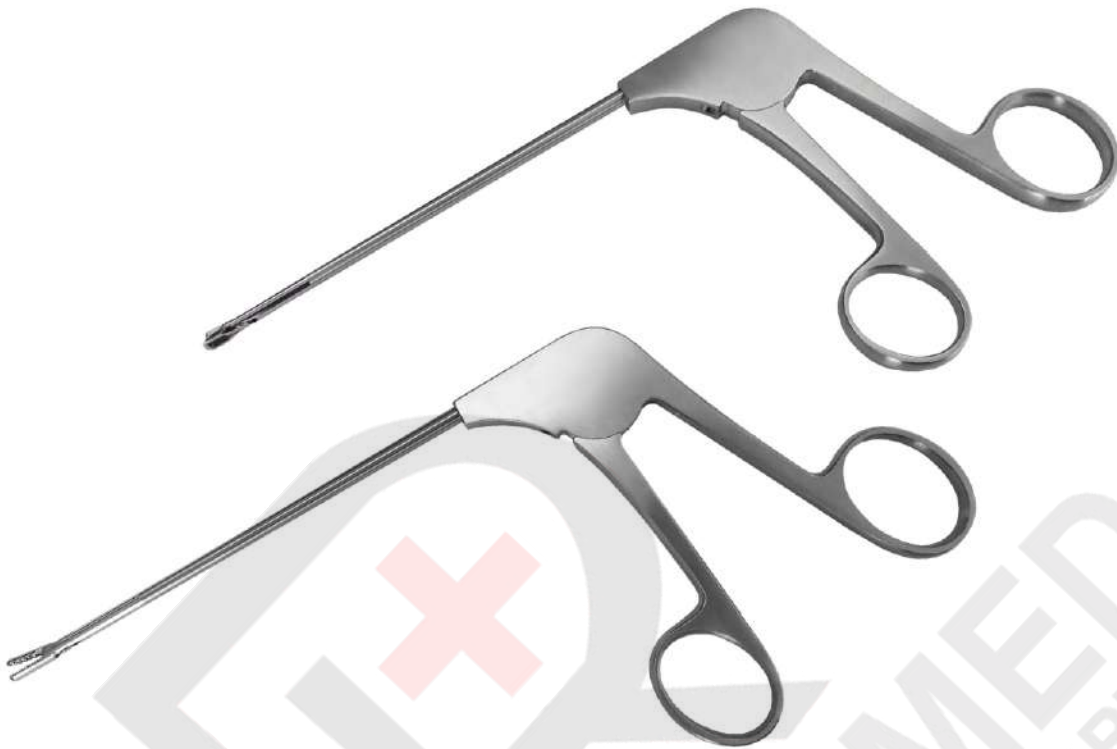

Arthroscopy Arthroscopie

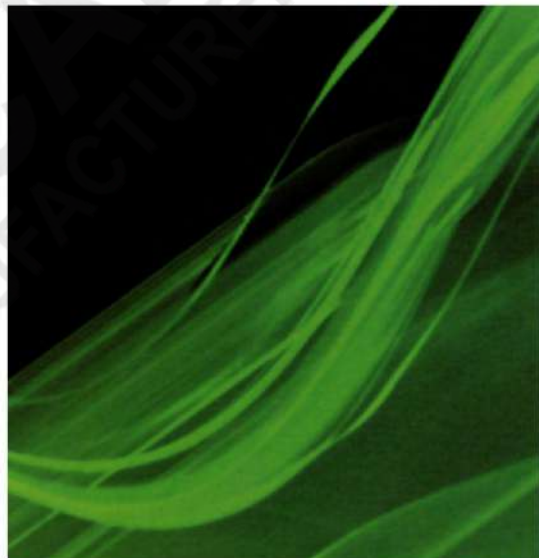

SURGICAL INSTRUMENTS



NEW
Nouveau

Advantage of the new series:

- New precision guidance for high cutting power with light pressure
- Optimal precise cutting at high load capacity

Avantage de la nouvelle série:

- Nouveau guidage de précision pour une puissance de coupe élevée avec une légère pression
- Coupe précise optimale à capacité de charge élevée



SURGICAL INSTRUMENTS



		cutting width, 3.2mm largeur de coupe, 3.2mm
Wide jaw Punch <i>Poinçon mors large</i>	straight <i>droit</i>	32.001
Wide jaw Punch <i>Poinçon mors large</i>	straight, jaws 15° angled up <i>droit, mors 15° angulé en haut</i>	32.002
Wide jaw Punch <i>Poinçon mors large</i>	curved shaft up <i>tige courbe en haut</i>	32.003
Wide jaw Punch <i>Poinçon mors large</i>	curved shaft right <i>tige courbe à droite</i>	32.004
Wide jaw Punch <i>Poinçon mors large</i>	curved shaft left <i>tige courbe à gauche</i>	32.005



		width, 3.4mm largeur, 3.4mm
Grasping Forceps, cupped <i>Pince préhensive, creuse</i>	straight <i>droite</i>	35.001



		width, 3.0mm largeur, 3.0mm
Alligator Forceps <i>Pince alligator</i>	straight <i>droite</i>	35.002



Advantage of the new series:

- New precision guidance for high cutting power with light pressure
- Optimal precise cutting at high load capacity

Avantage de la nouvelle série:

- Nouveau guidage de précision pour une puissance de coupe élevée avec une légère pression
- Coupe précise optimale à capacité de charge élevée



		cutting width, 1.7mm largeur de coupe, 1.7mm	cutting width, 2.0mm largeur de coupe, 2.0mm
Hook Punch with scoop <i>Poinçon crochet avec pelle</i>	straight <i>droit</i>	16.001	20.001
Hook Punch with scoop <i>Poinçon crochet avec pelle</i>	curved shaft up <i>tige courbe en haut</i>		cutting width, 1.6mm largeur de coupe, 1.6mm 16.002
Hook Punch with scoop <i>Poinçon crochet avec pelle</i>	straight, jaws 15° angled up <i>droit, mors 15° angulé en haut</i>		16.003
Hook Punch with scoop <i>Poinçon crochet avec pelle</i>	curved shaft right <i>tige courbe à droite</i>		16.004
Hook Punch with scoop <i>Poinçon crochet avec pelle</i>	curved shaft left <i>tige courbe à gauche</i>		16.005
Retrograde Punch <i>Poinçon rétrograde</i>	right cutting <i>coupe à droite</i>		24.001
Retrograde Punch <i>Poinçon rétrograde</i>	left cutting <i>coupe à gauche</i>		24.002



New
Nouveau

Advantage of the new series:

- New precision guidance for high cutting power with light pressure
- Optimal precise cutting at high load capacity

Avantage de la nouvelle série:

- Nouveau guidage de précision pour une puissance de coupe élevée avec une légère pression
- Coupe précise optimale à capacité de charge élevée



cutting width, 1.4mm
largeur de coupe, 1.4mm

Scissors Punch <i>Poinçon ciseaux</i>	straight <i>droit</i>	14.001
Scissors Punch <i>Poinçon ciseaux</i>	curved shaft up <i>tige courbe en haut</i>	14.002
Scissors Punch <i>Poinçon ciseaux</i>	curved shaft right <i>tige courbe à droite</i>	14.003
Scissors Punch <i>Poinçon ciseaux</i>	curved shaft left <i>tige courbe à gauche</i>	14.004



cutting width, 4.4mm
largeur de coupe, 4.4mm

Punch oval <i>Poinçon oval</i>	straight <i>droit</i>	44.001
Punch oval <i>Poinçon oval</i>	curved shaft up <i>tige courbe en haut</i>	44.002
Punch oval <i>Poinçon oval</i>	curved shaft right <i>tige courbe à droite</i>	44.003
Punch oval <i>Poinçon oval</i>	curved shaft left <i>tige courbe à gauche</i>	44.004

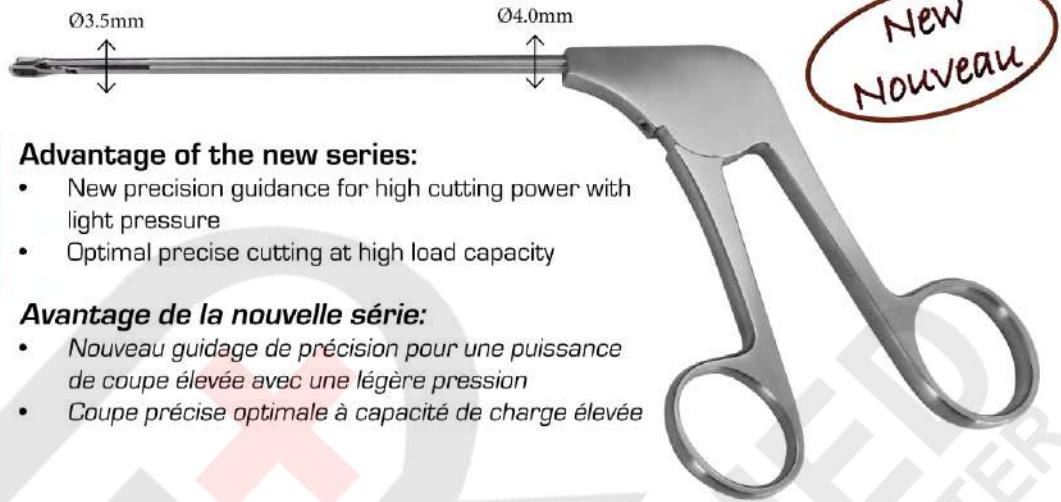

Advantage of the new series:

- New precision guidance for high cutting power with light pressure
- Optimal precise cutting at high load capacity

Avantage de la nouvelle série:

- Nouveau guidage de précision pour une puissance de coupe élevée avec une légère pression
- Coupe précise optimale à capacité de charge élevée

cutting width, 1.6mm
largeur de coupe, 1.6mm



Hook Punch blunt <i>Painçon crochet arrondi</i>	straight <i>droit</i>	16.006
Hook Punch blunt <i>Painçon crochet arrondi</i>	curved shaft up <i>tige courbe en haut</i>	16.007
Hook Punch blunt <i>Painçon crochet arrondi</i>	straight, jaws 15° angled up <i>droit, mors 15° angulé en haut</i>	16.008
Hook Punch blunt <i>Painçon crochet arrondi</i>	curved shaft right <i>tige courbe à droite</i>	16.009
Hook Punch blunt <i>Painçon crochet arrondi</i>	curved shaft left <i>tige courbe à gauche</i>	16.010



All instruments with integrated overload protection
Tous les instruments ont un système intégré de surcharge de pression

SURGICAL INSTRUMENTS



			Ø2.7mm	Ø3.5mm
Hook Scissors <i>Crochet ciseaux</i>	straight <i>droit</i>		250.270	250.350
Hook Scissors <i>Crochet ciseaux</i>	30° curved right <i>30° courbe à droite</i>		251.270	251.350
Hook Scissors <i>Crochet ciseaux</i>	30° curved left <i>30° courbe à gauche</i>		253.270	253.350
Hook Scissors <i>Crochet ciseaux</i>	45° curved right <i>45° courbe à droite</i>		255.270	255.350
Hook Scissors <i>Crochet ciseaux</i>	45° curved left <i>45° courbe à gauche</i>		257.270	257.350
Hook Scissors <i>Crochet ciseaux</i>	7° curved up <i>7° courbe en haut</i>		259.270	259.350
Hook Scissors <i>Crochet ciseaux</i>	7° curved down <i>7° courbe en bas</i>		261.270	261.350
Hook Scissors <i>Crochet ciseaux</i>	15° curved up <i>15° courbe en haut</i>		263.270	263.350
Hook Scissors <i>Crochet ciseaux</i>	15° curved down <i>15° courbe en bas</i>		265.270	265.350



All instruments with integrated overload protection
Tous les instruments ont un système intégré de surcharge de pression



			Ø2.7mm	Ø3.5mm
Hook Punch with scoop <i>Poinçon crochet avec pelle</i>	straight <i>droit</i>		290.270	290.350
Hook Punch with scoop <i>Poinçon crochet avec pelle</i>	30° curved right <i>30° courbe à droite</i>		291.270	291.350
Hook Punch with scoop <i>Poinçon crochet avec pelle</i>	30° curved left <i>30° courbe à gauche</i>		293.270	293.350
Hook Punch with scoop <i>Poinçon crochet avec pelle</i>	45° curved right <i>45° courbe à droite</i>		295.270	295.350
Hook Punch with scoop <i>Poinçon crochet avec pelle</i>	45° curved left <i>45° courbe à gauche</i>		297.270	297.350
Hook Punch with scoop <i>Poinçon crochet avec pelle</i>	7° curved up <i>7° courbe en haut</i>		299.270	299.350
Hook Punch with scoop <i>Poinçon crochet avec pelle</i>	7° curved down <i>7° courbe en bas</i>		301.270	301.350
Hook Punch with scoop <i>Poinçon crochet avec pelle</i>	15° curved up <i>15° courbe en haut</i>		303.270	303.350
Hook Punch with scoop <i>Poinçon crochet avec pelle</i>	15° curved down <i>15° courbe en bas</i>		305.270	305.350



All instruments with integrated overload protection
Tous les instruments ont un système intégré de surcharge de pression

SURGICAL INSTRUMENTS



			Ø2.7mm	Ø3.5mm
Hook Punch set down <i>Poinçon crochet régulier</i>	straight <i>droit</i>		350.270	350.350
Hook Punch set down <i>Poinçon crochet régulier</i>	30° curved right <i>30° courbe à droite</i>		351.270	351.350
Hook Punch set down <i>Poinçon crochet régulier</i>	30° curved left <i>30° courbe à gauche</i>		353.270	353.350
Hook Punch set down <i>Poinçon crochet régulier</i>	45° curved right <i>45° courbe à droite</i>		355.270	355.350
Hook Punch set down <i>Poinçon crochet régulier</i>	45° curved left <i>45° courbe à gauche</i>		357.270	357.350
Hook Punch set down <i>Poinçon crochet régulier</i>	7° curved up <i>7° courbe en haut</i>		359.270	359.350
Hook Punch set down <i>Poinçon crochet régulier</i>	7° curved down <i>7° courbe en bas</i>		361.270	361.350
Hook Punch set down <i>Poinçon crochet régulier</i>	15° curved up <i>15° courbe en haut</i>		363.270	363.350
Hook Punch set down <i>Poinçon crochet régulier</i>	15° curved down <i>15° courbe en bas</i>		365.270	365.350

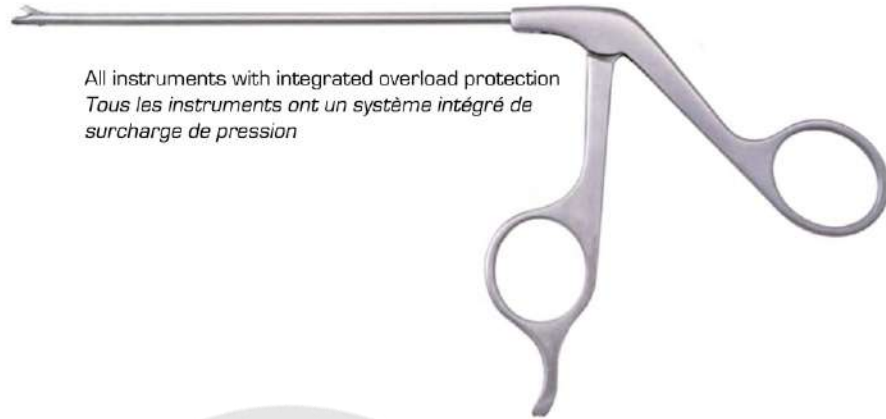

All instruments with integrated overload protection
 Tous les instruments ont un système intégré de surcharge de pression



Ø3.5mm

Hook Punch, square cut <i>Poinçon crochet, tranchant carré</i>	straight <i>droit</i>		370.350
Hook Punch, square cut <i>Poinçon crochet, tranchant carré</i>	30° curved right <i>30° courbe à droite</i>		371.350
Hook Punch, square cut <i>Poinçon crochet, tranchant carré</i>	30° curved left <i>30° courbe à gauche</i>		373.350
Hook Punch, square cut <i>Poinçon crochet, tranchant carré</i>	45° curved right <i>45° courbe à droite</i>		375.350
Hook Punch, square cut <i>Poinçon crochet, tranchant carré</i>	45° curved left <i>45° courbe à gauche</i>		377.350
Hook Punch, square cut <i>Poinçon crochet, tranchant carré</i>	7° curved up <i>7° courbe en haut</i>		379.350
Hook Punch, square cut <i>Poinçon crochet, tranchant carré</i>	7° curved down <i>7° courbe en bas</i>		381.350
Hook Punch, square cut <i>Poinçon crochet, tranchant carré</i>	15° curved up <i>15° courbe en haut</i>		383.350
Hook Punch, square cut <i>Poinçon crochet, tranchant carré</i>	15° curved down <i>15° courbe en bas</i>		385.350

SURGICAL INSTRUMENTS

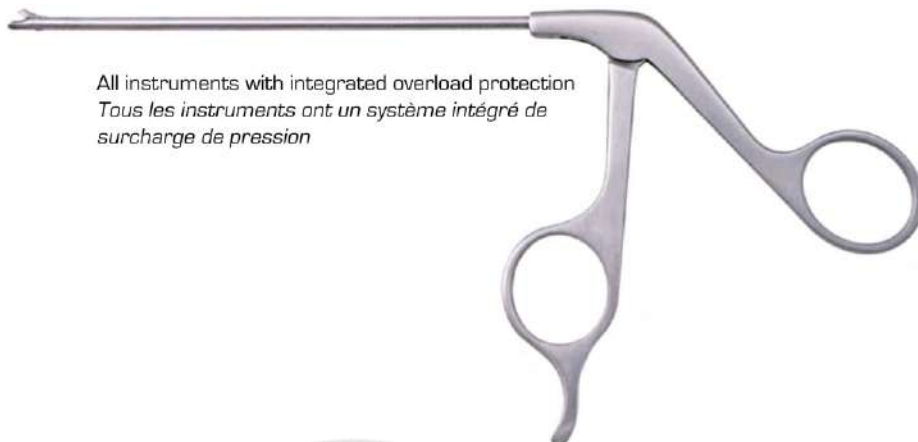

All instruments with integrated overload protection
Tous les instruments ont un système intégré de surcharge de pression

SURGICAL INSTRUMENTS

Ø3.5mm



Hook Punch 15° up milled <i>Poinçon crochet mors angulé 15°</i>	straight <i>droit</i>		390.350
Hook Punch 15° up milled <i>Poinçon crochet mors angulé 15°</i>	30° curved right <i>30° courbe à droite</i>		391.350
Hook Punch 15° up milled <i>Poinçon crochet mors angulé 15°</i>	30° curved left <i>30° courbe à gauche</i>		393.350
Hook Punch 15° up milled <i>Poinçon crochet mors angulé 15°</i>	45° curved right <i>45° courbe à droite</i>		395.350
Hook Punch 15° up milled <i>Poinçon crochet mors angulé 15°</i>	45° curved left <i>45° courbe à gauche</i>		397.350
Hook Punch 15° up milled <i>Poinçon crochet mors angulé 15°</i>	7° curved up <i>7° courbe en haut</i>		399.350
Hook Punch 15° up milled <i>Poinçon crochet mors angulé 15°</i>	7° curved down <i>7° courbe en bas</i>		401.350
Hook Punch 15° up milled <i>Poinçon crochet mors angulé 15°</i>	15° curved up <i>15° courbe en haut</i>		403.350
Hook Punch 15° up milled <i>Poinçon crochet mors angulé 15°</i>	15° curved down <i>15° courbe en bas</i>		405.350

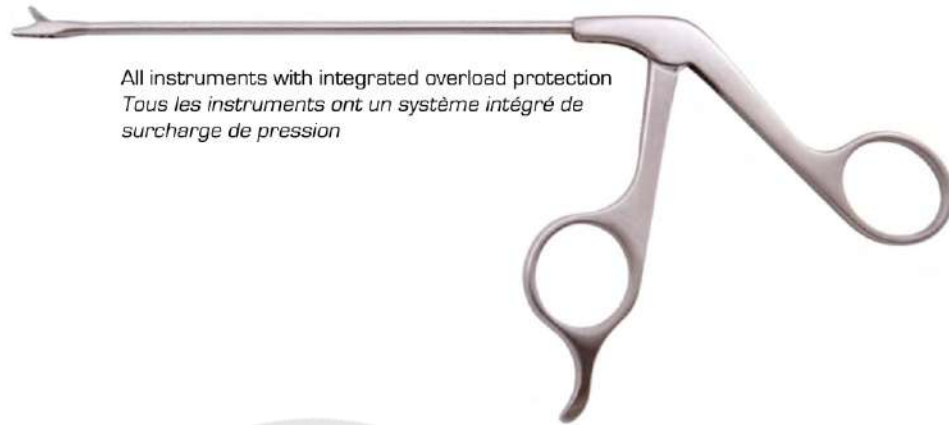

All instruments with integrated overload protection
Tous les instruments ont un système intégré de surcharge de pression



Ø3.5mm

Wide Jaw Punch large <i>Large poinçon grand mors</i>	straight <i>droit</i>		490.350
Wide Jaw Punch large <i>Large poinçon grand mors</i>	30° curved right <i>30° courbe à droite</i>		491.350
Wide Jaw Punch large <i>Large poinçon grand mors</i>	30° curved left <i>30° courbe à gauche</i>		493.350
Wide Jaw Punch large <i>Large poinçon grand mors</i>	45° curved right <i>45° courbe à droite</i>		495.350
Wide Jaw Punch large <i>Large poinçon grand mors</i>	45° curved left <i>45° courbe à gauche</i>		497.350
Wide Jaw Punch large <i>Large poinçon grand mors</i>	7° curved up <i>7° courbe en haut</i>		499.350
Wide Jaw Punch large <i>Large poinçon grand mors</i>	7° curved down <i>7° courbe en bas</i>		501.350
Wide Jaw Punch large <i>Large poinçon grand mors</i>	15° curved up <i>15° courbe en haut</i>		503.350
Wide Jaw Punch large <i>Large poinçon grand mors</i>	15° curved down <i>15° courbe en bas</i>		505.350



All instruments with integrated overload protection
Tous les instruments ont un système intégré de surcharge de pression

SURGICAL INSTRUMENTS



				Ø3.5mm
Wide Jaw Punch medium Large poinçon mors moyen	straight droit		560.350	
Wide Jaw Punch medium Large poinçon mors moyen	30° curved right 30° courbe à droite		561.350	
Wide Jaw Punch medium Large poinçon mors moyen	30° curved left 30° courbe à gauche		563.350	
Wide Jaw Punch medium Large poinçon mors moyen	45° curved right 45° courbe à droite		565.350	
Wide Jaw Punch medium Large poinçon mors moyen	45° curved left 45° courbe à gauche		567.350	
Wide Jaw Punch medium Large poinçon mors moyen	7° curved up 7° courbe en haut		569.350	
Wide Jaw Punch medium Large poinçon mors moyen	7° curved down 7° courbe en bas		571.350	
Wide Jaw Punch medium Large poinçon mors moyen	15° curved up 15° courbe en haut		573.350	
Wide Jaw Punch medium Large poinçon mors moyen	15° curved down 15° courbe en bas		575.350	



All instruments with integrated overload protection
Tous les instruments ont un système intégré de surcharge de pression



Ø3.5mm

Wide Jaw Punch small Large poinçon petit mors	straight droit		630.350
Wide Jaw Punch small Large poinçon petit mors	30° curved right 30° courbe à droite		631.350
Wide Jaw Punch small Large poinçon petit mors	30° curved left 30° courbe à gauche		633.350
Wide Jaw Punch small Large poinçon petit mors	45° curved right 45° courbe à droite		635.350
Wide Jaw Punch small Large poinçon petit mors	45° curved left 45° courbe à gauche		637.350
Wide Jaw Punch small Large poinçon petit mors	7° curved up 7° courbe en haut		639.350
Wide Jaw Punch small Large poinçon petit mors	7° curved down 7° courbe en bas		641.350
Wide Jaw Punch small Large poinçon petit mors	15° curved up 15° courbe en haut		643.350
Wide Jaw Punch small Large poinçon petit mors	15° curved down 15° courbe en bas		645.350



All instruments with integrated overload protection
Tous les instruments ont un système intégré de surcharge de pression

SURGICAL INSTRUMENTS

Ø3.5mm



Wide Jaw Punch Large, 15° up <i>Large poinçon, grand mors angulé 15°</i>	straight <i>droit</i>		530.350
Wide Jaw Punch Large, 15° up <i>Large poinçon, grand mors angulé 15°</i>	30° curved right <i>30° courbe à droite</i>		531.350
Wide Jaw Punch Large, 15° up <i>Large poinçon, grand mors angulé 15°</i>	30° curved left <i>30° courbe à gauche</i>		533.350
Wide Jaw Punch Large, 15° up <i>Large poinçon, grand mors angulé 15°</i>	45° curved right <i>45° courbe à droite</i>		535.350
Wide Jaw Punch Large, 15° up <i>Large poinçon, grand mors angulé 15°</i>	45° curved left <i>45° courbe à gauche</i>		537.350
Wide Jaw Punch Large, 15° up <i>Large poinçon, grand mors angulé 15°</i>	7° curved up <i>7° courbe en haut</i>		539.350
Wide Jaw Punch Large, 15° up <i>Large poinçon, grand mors angulé 15°</i>	7° curved down <i>7° courbe en bas</i>		541.350
Wide Jaw Punch Large, 15° up <i>Large poinçon, grand mors angulé 15°</i>	15° curved up <i>15° courbe en haut</i>		543.350
Wide Jaw Punch Large, 15° up <i>Large poinçon, grand mors angulé 15°</i>	15° curved down <i>15° courbe en bas</i>		545.350

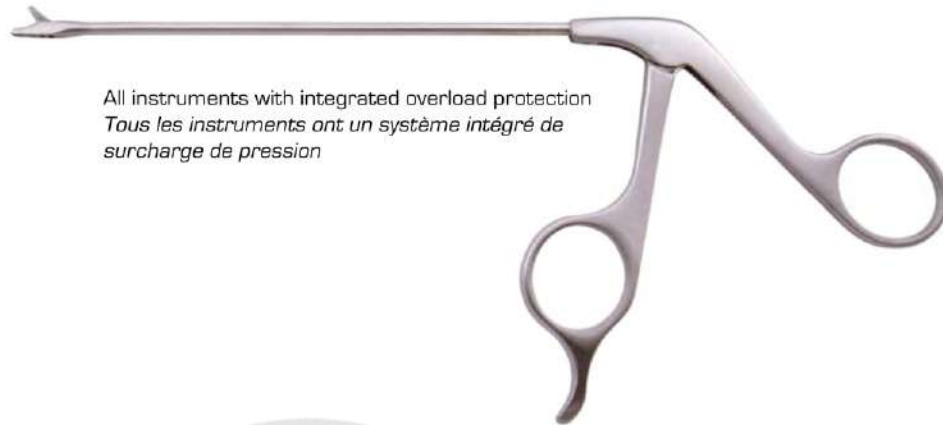







All instruments with integrated overload protection
Tous les instruments ont un système intégré de surcharge de pression



5.0 x 3.5mm

Ø3.5mm

Wide Jaw Punch Medium, 15° up <i>Large poinçon, mors moyen angulé 15°</i>	straight <i>droit</i>		600.350
Wide Jaw Punch Medium, 15° up <i>Large poinçon, mors moyen angulé 15°</i>	30° curved right <i>30° courbe à droite</i>		601.350
Wide Jaw Punch Medium, 15° up <i>Large poinçon, mors moyen angulé 15°</i>	30° curved left <i>30° courbe à gauche</i>		603.350
Wide Jaw Punch Medium, 15° up <i>Large poinçon, mors moyen angulé 15°</i>	45° curved right <i>45° courbe à droite</i>		605.350
Wide Jaw Punch Medium, 15° up <i>Large poinçon, mors moyen angulé 15°</i>	45° curved left <i>45° courbe à gauche</i>		607.350
Wide Jaw Punch Medium, 15° up <i>Large poinçon, mors moyen angulé 15°</i>	7° curved up <i>7° courbe en haut</i>		609.350
Wide Jaw Punch Medium, 15° up <i>Large poinçon, mors moyen angulé 15°</i>	7° curved down <i>7° courbe en bas</i>		611.350
Wide Jaw Punch Medium, 15° up <i>Large poinçon, mors moyen angulé 15°</i>	15° curved up <i>15° courbe en haut</i>		613.350
Wide Jaw Punch Medium, 15° up <i>Large poinçon, mors moyen angulé 15°</i>	15° curved down <i>15° courbe en bas</i>		615.350











All instruments with integrated overload protection
Tous les instruments ont un système intégré de surcharge de pression

Ø3.5mm

SURGICAL INSTRUMENTS

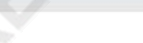
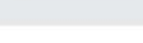

Wide Jaw Punch Small, 15° up <i>Large poinçon, petit mors angulé 15°</i>	straight <i>droit</i>		680.350
Wide Jaw Punch Small, 15° up <i>Large poinçon, petit mors angulé 15°</i>	30° curved right <i>30° courbe à droite</i>		681.350
Wide Jaw Punch Small, 15° up <i>Large poinçon, petit mors angulé 15°</i>	30° curved left <i>30° courbe à gauche</i>		683.350
Wide Jaw Punch Small, 15° up <i>Large poinçon, petit mors angulé 15°</i>	45° curved right <i>45° courbe à droite</i>		685.350
Wide Jaw Punch Small, 15° up <i>Large poinçon, petit mors angulé 15°</i>	45° curved left <i>45° courbe à gauche</i>		687.350
Wide Jaw Punch Small, 15° up <i>Large poinçon, petit mors angulé 15°</i>	7° curved up <i>7° courbe en haut</i>		689.350
Wide Jaw Punch Small, 15° up <i>Large poinçon, petit mors angulé 15°</i>	7° curved down <i>7° courbe en bas</i>		691.350
Wide Jaw Punch Small, 15° up <i>Large poinçon, petit mors angulé 15°</i>	15° curved up <i>15° courbe en haut</i>		693.350
Wide Jaw Punch Small, 15° up <i>Large poinçon, petit mors angulé 15°</i>	15° curved down <i>15° courbe en bas</i>		695.350

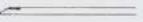

Wide Jaw Punch Small, 45° up <i>Large poinçon, petit mors angulé 45°</i>	straight <i>droit</i>		698.350
---	--------------------------	---	---------

All instruments with integrated overload protection
Tous les instruments ont un système intégré de surcharge de pression



Ø3.5mm



45° Hook Scissors
Ciseaux crochet 45° right angled
angulé à droite

270.350



45° Hook Scissors
Ciseaux crochet 45° left angled
angulé à gauche

280.350



45° Punch with Scoop
Poinçon 45° avec pelle right angled
angulé à droite

420.350



45° Punch with Scoop
Poinçon 45° avec pelle left angled
angulé à gauche

440.350



45° Punch blunt
Poinçon 45°, arrondi right angled
angulé à droite

410.350



45° Punch blunt
Poinçon 45°, arrondi left angled
angulé à gauche

430.350









SURGICAL INSTRUMENTS



All instruments with integrated overload protection
Tous les instruments ont un système intégré de surcharge de pression

SURGICAL INSTRUMENTS

Ø3.5mm

 4.5 x 1.6mm	90° Punch with scoop <i>Poinçon 90° avec pelle</i>	small <i>petit</i>	right angled <i>angulé à droite</i>	450.350
 4.5 x 1.6mm	90° Punch with scoop <i>Poinçon 90° avec pelle</i>	small <i>petit</i>	left angled <i>angulé à gauche</i>	470.350
 4.5 x 1.6mm	90° Punch blunt <i>Poinçon 90°, arrondi</i>	small <i>petit</i>	right angled <i>angulé à droite</i>	460.350
 4.5 x 1.6mm	90° Punch blunt <i>Poinçon 90°, arrondi</i>	small <i>petit</i>	left angled <i>angulé à gauche</i>	480.350
 7.0 x 1.8mm	90° Wide Jaw Punch <i>Large poinçon 90°</i>	medium <i>moyen</i>	right angled <i>angulé à droite</i>	760.350
 7.0 x 1.8mm	90° Wide Jaw Punch <i>Large poinçon 90°</i>	medium <i>moyen</i>	left angled <i>angulé à gauche</i>	770.350
 7.0 x 3.0mm	90° Wide Jaw Punch <i>Large poinçon 90°</i>	large <i>grand</i>	right angled <i>angulé à droite</i>	740.350
 7.0 x 3.0mm	90° Wide Jaw Punch <i>Large poinçon 90°</i>	large <i>grand</i>	left angled <i>angulé à gauche</i>	750.350



All instruments with integrated overload protection
Tous les instruments ont un système intégré de surcharge de pression



5.0 x 0.8mm

Ø3.5mm

Scissors Punch <i>Poinçon ciseaux</i>	straight <i>droit</i>		700.350
Scissors Punch <i>Poinçon ciseaux</i>	30° curved right <i>30° courbe à droite</i>		701.350
Scissors Punch <i>Poinçon ciseaux</i>	30° curved left <i>30° courbe à gauche</i>		703.350
Scissors Punch <i>Poinçon ciseaux</i>	45° curved right <i>45° courbe à droite</i>		705.350
Scissors Punch <i>Poinçon ciseaux</i>	45° curved left <i>45° courbe à gauche</i>		707.350
Scissors Punch <i>Poinçon ciseaux</i>	7° curved up <i>7° courbe en haut</i>		709.350
Scissors Punch <i>Poinçon ciseaux</i>	7° curved down <i>7° courbe en bas</i>		711.350
Scissors Punch <i>Poinçon ciseaux</i>	15° curved up <i>15° courbe en haut</i>		713.350
Scissors Punch <i>Poinçon ciseaux</i>	15° curved down <i>15° courbe en bas</i>		715.350



All instruments with integrated overload protection
Tous les instruments ont un système intégré de surcharge de pression

SURGICAL INSTRUMENTS

Ø3.5mm



Scissors Punch 15° up milled <i>Poinçon ciseaux, mors angulé 15°</i>	straight <i>droit</i>		720.350
Scissors Punch 15° up milled <i>Poinçon ciseaux, mors angulé 15°</i>	30° curved right <i>30° courbe à droite</i>		721.350
Scissors Punch 15° up milled <i>Poinçon ciseaux, mors angulé 15°</i>	30° curved left <i>30° courbe à gauche</i>		723.350
Scissors Punch 15° up milled <i>Poinçon ciseaux, mors angulé 15°</i>	45° curved right <i>45° courbe à droite</i>		725.350
Scissors Punch 15° up milled <i>Poinçon ciseaux, mors angulé 15°</i>	45° curved left <i>45° courbe à gauche</i>		727.350
Scissors Punch 15° up milled <i>Poinçon ciseaux, mors angulé 15°</i>	7° curved up <i>7° courbe en haut</i>		729.350
Scissors Punch 15° up milled <i>Poinçon ciseaux, mors angulé 15°</i>	7° curved down <i>7° courbe en bas</i>		731.350
Scissors Punch 15° up milled <i>Poinçon ciseaux, mors angulé 15°</i>	15° curved up <i>15° courbe en haut</i>		733.350
Scissors Punch 15° up milled <i>Poinçon ciseaux, mors angulé 15°</i>	15° curved down <i>15° courbe en bas</i>		735.350



All instruments with integrated overload protection
 Tous les instruments ont un système intégré de surcharge de pression

Ø3.5mm



Cut left
 Coupe à gauche

straight
 droit

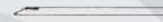

780.350



Cut right
 Coupe à droite

straight
 droit



790.350

SURGICAL INSTRUMENTS





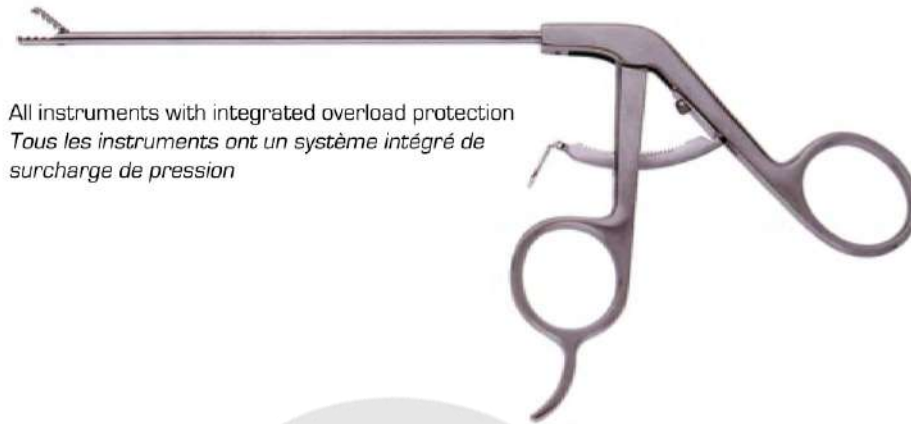

All instruments with integrated overload protection
Tous les instruments ont un système intégré de surcharge de pression

SURGICAL INSTRUMENTS

		Ø2.7mm	Ø3.5mm
	Grasping Forceps <i>Pince préhensive</i>	800.270	800.350
	Grasping Forceps, 1 x 2 teeth, fine <i>Pince préhensive, 1 x 2 dents, fine</i>		820.350
	Grasping Forceps, 1 x 2 teeth <i>Pince préhensive, 1 x 2 dents</i>		840.350
	Grasping and Biopsy Forceps <i>Pince préhensive à biopsie</i>		860.350
	Biopsy Spoon Forceps <i>Pince curette à biopsie</i>		880.350
			Ø4.5mm
	Bulldog Grasping Forceps, 1 x 2 teeth <i>Pince préhensive Bulldog, 1 x 2 dents</i>		845.350



All instruments with integrated overload protection
Tous les instruments ont un système intégré de surcharge de pression

	Ø2.7mm	Ø3.5mm	
	Grasping Forceps <i>Pince préhensive</i>	800.270.R	800.350.R
	Grasping Forceps, 1 x 2 teeth, fine <i>Pince préhensive, 1 x 2 dents, fine</i>		820.350.R
	Grasping Forceps, 1 x 2 teeth <i>Pince préhensive, 1 x 2 dents</i>		840.350.R
	Grasping and Biopsy Forceps <i>Pince préhensive à biopsie</i>		860.350.R
	Biopsy Spoon Forceps <i>Pince curette à biopsie</i>		880.350.R
			Ø4.5mm
	Bulldog Grasping Forceps, 1 x 2 teeth <i>Pince préhensive Bulldog, 1 x 2 dents</i>		845.350.R

All instruments with integrated overload protection
Tous les instruments ont un système intégré de surcharge de pression



170.001

Mini Grasping Forceps, 1 x 2 teeth, working length 130mm, ergonomic handle with ratchet, dismountable

Mini pince préhensive, 1 x 2 dents, distance de travail 130mm, manche ergonomique avec crémaillère, démontable



All instruments with integrated overload protection
Tous les instruments ont un système intégré de surcharge de pression



190.001

Meniscus Grasping Forceps, strong jaws 4.5 x 15mm, working length 120mm, ergonomic handle, dismountable

Pince préhensive à ménisque, mors robuste 4.5 x 15mm, distance de travail 120mm, manche ergonomique, démontable



180.001

Tendon Grasping Forceps, straight, ergonomic handle with ratchet, overall length 190mm

Pince préhensive pour tendons, droite, manche ergonomique avec crémaillère, longueur totale 190mm



180.002

Tendon Grasping Forceps, right, with ratchet

Pince préhensive pour tendons, à droite, avec crémaillère



180.003

Tendon Grasping Forceps, left, with ratchet

Pince préhensive pour tendons, à gauche, avec crémaillère



180.001.01

Caroll Tendon Grasping Forceps

Pince préhensive Caroll pour tendons

All instruments with integrated overload protection
Tous les instruments ont un système intégré de surcharge de pression



All instruments with integrated overload protection
Tous les instruments ont un système intégré de surcharge de pression

SURGICAL INSTRUMENTS

Ø3.5mm

	Suture Grasping Forceps, straight <i>Pince préhensive pour suture, droite</i>	890.350
	Suture Grasping Forceps, 45° sharp up milled <i>Pince préhensive pour suture, mors 45° coupant en haut</i>	893.350
	Suture Grasping Forceps, 10° sharp up milled <i>Pince préhensive pour suture, mors 10° coupant en haut</i>	895.350
	Suture Pierce sharp, straight <i>Pince Pierce pour suture, droite</i>	900.350
	Pointed Suture Forceps, straight <i>Pince pointue pour suture, droite</i>	901.350



Sheath Ø4.5mm, Working Length 130mm
Tige Ø4.5mm, distance de travail 130mm

All instruments with integrated overload protection
Tous les instruments ont un système intégré de surcharge de pression



199.001

Punch up cutting
Poinçon coupant en haut



199.002

Hook Punch
Poinçon crochet

SURGICAL INSTRUMENTS

GRASPERS

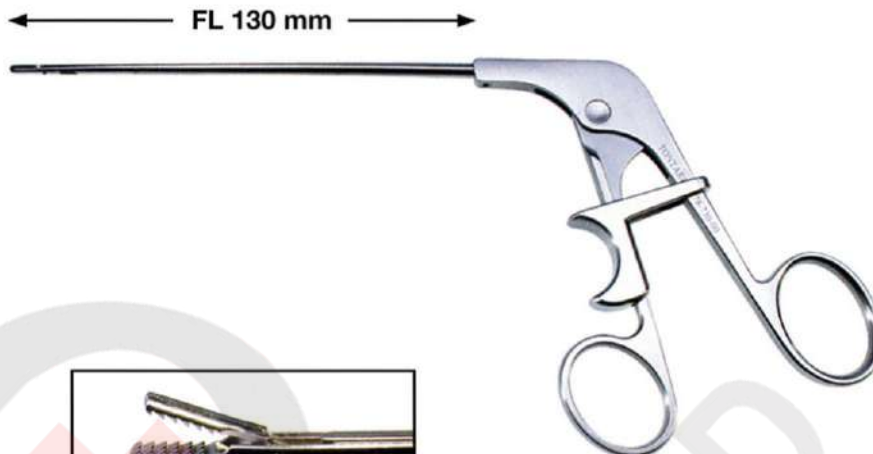

Grasper Alligator;
maximum; locking handle



Art. Nr.	Description	Sheath versions	Tip profile	Jaw wide
578-720-00	straight		3,20 mm	3,50 mm
578-720-02	curved up 15°		3,20 mm	3,50 mm

Grasper Alligator;
fine; locking handle



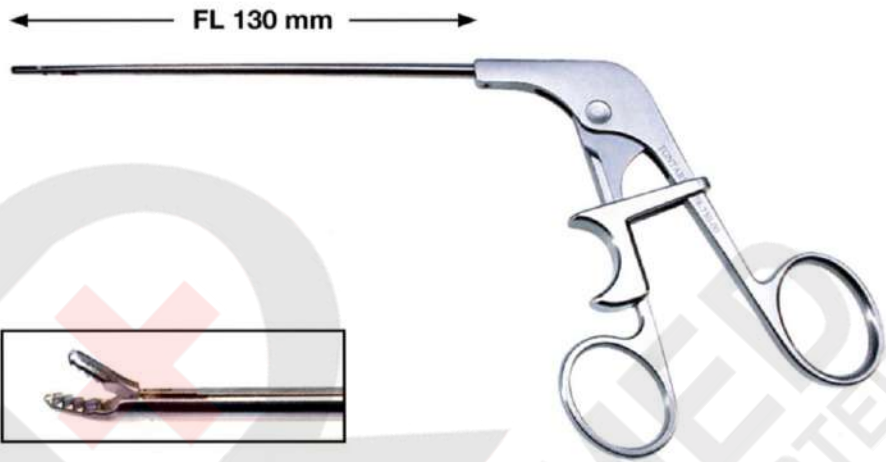

Art. Nr.	Description	Sheath versions	Tip profile	Jaw wide
578-715-00	straight; fine		2,70 mm	3,00 mm
578-715-02	curved up 15°; fine		2,70 mm	3,00 mm

GRASPERS



Grasper Alligator;
upbiter fine; locking handle

Art. Nr.	Description	Sheath versions	Tip profile	Jaw wide
578-715-10	upbiter straight; fine		2,70 mm	3,00 mm
578-715-12	upbiter curved up 15°; fine		2,70 mm	3,00 mm

Grasper;
1 x 2 teeth; locking handle



Art. Nr.	Description	Sheath versions	Jaw wide
578-710-00	straight		3,45 mm

GRASPERS

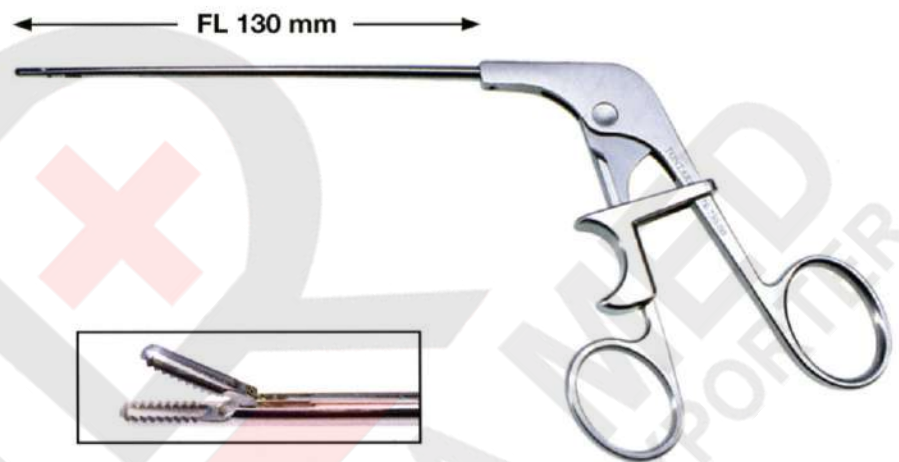

Grasper cupped;
locking handle

Art. Nr.	Description	Sheath versions	Jaw wide
578-730-00	straight		2,70 mm
578-735-00	straight		3,40 mm



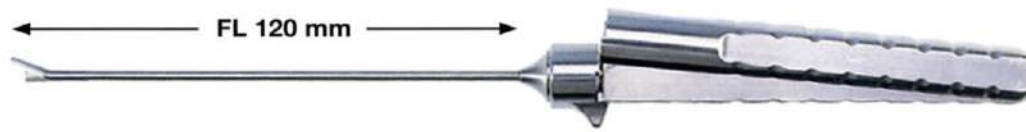

SURGICAL INSTRUMENTS



Instruments with rotating function | **AXIAL handle**







AXIAL handle with locking;
basket punch 90°



Art. Nr.	Description	Sheath versions	Bite wide
578-810-30	90° jaw left		2,20 mm
578-815-40	90° jaw right		2,20 mm
578-820-30	90° jaw left		3,40 mm
578-825-40	90° jaw right		3,40 mm

AXIAL handle with locking;
scissors



Art. Nr.	Description	Sheath versions
578-910-30	20° scissors jaw left	
578-915-40	20° scissors jaw right	
578-920-30	20° serrated scissors jaw left	
578-925-40	20° serrated scissors jaw right	
578-930-30	60° scissors jaw left	
578-935-40	60° scissors jaw right	

FL 120 mm



Instruments with rotating function | **Standard handle**

Standard handle;
basket punch 90°



Art. Nr.	Description	Sheath versions	Bite wide
578-810-39	90° jaw left		2,20 mm
578-815-49	90° jaw right		2,20 mm
578-820-39	90° jaw left		3,40 mm
578-825-49	90° jaw right		3,40 mm

Standard handle;
scissors



Art. Nr.	Description	Sheath versions
578-910-39	20° scissors jaw left	
578-915-49	20° scissors jaw right	
578-920-39	20° serrated scissors jaw left	
578-925-49	20° serrated scissors jaw right	
578-930-39	60° scissors jaw left	
578-935-49	60° scissors jaw right	

Small joint instruments; graspers;
with locking handle

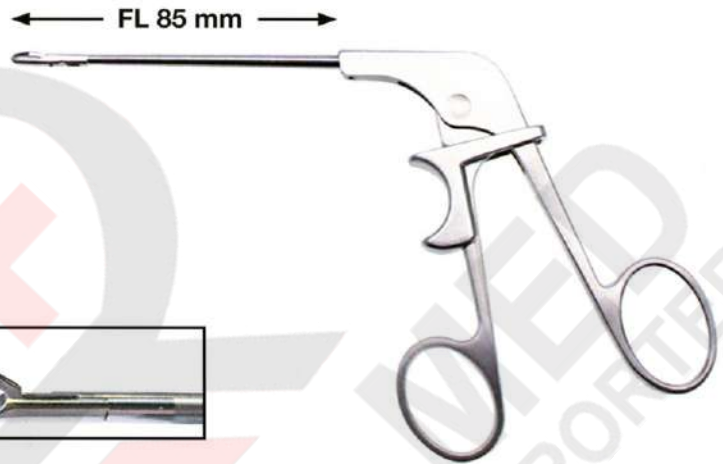

Grasper Alligator



Art. Nr.	Description	Sheath versions	Tip profile
578-994-00	straight		2,00 mm











Grasper;
1 x 2 teeth



Art. Nr.	Description	Sheath versions	Tip profile
578-995-00	straight		2,00 mm

Instruments bits for **adaptable handles**

Art.Nr.	Description	Size	Spez.
573-100-00	handle; only		
573-100-05	meniscus hook-probe pointed; bit		
573-100-10	meniscus hook-probe; graduated; bit	2,5 mm	
573-100-15	meniscus hook-probe; graduated; bit	3,5 mm	
573-100-17	meniscus hook-probe; graduated; bit	5,0 mm	
573-100-20	bayonet-knife; bit		
573-100-25	scalpel-knife; bit		
573-100-30	SMILLIE meniscotome; bit	3,0 mm	
573-100-35	SMILLIE meniscotome; bit	5,0 mm	
573-100-40	SMILLIE meniscotome; bit	7,0 mm	







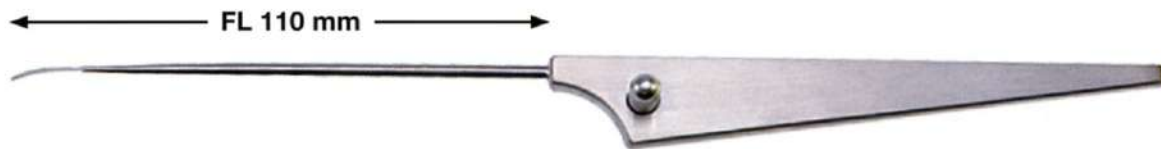



Art.Nr.	Description	Size	Spez.
573-100-00	handle; only		
	 <p>FL 125 mm</p>		
573-100-45	ring-curette 30°; bit	Ø 3,0 mm	
573-100-47	ring-curette 15°; bit	Ø 5,0 mm	
573-100-50	ring-curette 30°; bit	Ø 7,0 mm	
573-100-55	spoon; 30° curved; bit	Ø 3,0 mm	
573-100-60	banana-knife; smooth; bit		
573-100-65	banana-knife; serrated; bit		
573-100-70	hook-knife; bit	Ø 3,0 mm	
573-100-75	knife 45°; retrograde; bit	Ø 5,0 mm	
573-100-80	sickle-knife; bit		
573-100-85	rosette-knife; toothed; straight; bit		
573-100-90	cartilage-file; fine; bit		
573-100-95	cartilage-file; rough; bit		

SURGICAL INSTRUMENTS

Instruments with **triangular handles**

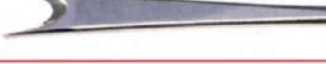

SURGICAL INSTRUMENTS

Art.Nr.	Description	Size	Spez.
573-200-05	meniscus hook-probe; pointed; handle		
573-200-10	meniscus hook-probe; graduated; handle;	3,0 mm	
573-200-15	meniscus hook-probe; graduated; handle	5,0 mm	
573-200-20	bayonet-knife; handle		
573-200-25	scalpel-knife; handle		
573-200-30	SMILLIE meniscotome; handle	3,0 mm	
573-200-35	SMILLIE meniscotome; handle	5,0 mm	
573-200-37	SMILLIE meniscotome; handle	7,0 mm	
573-200-40	ring-curette; 30° curved; handle	3,0 mm	
573-200-42	ring-curette; 15° curved; handle	5,0 mm	
573-200-45	ring-curette; 30° curved; handle	7,0 mm	

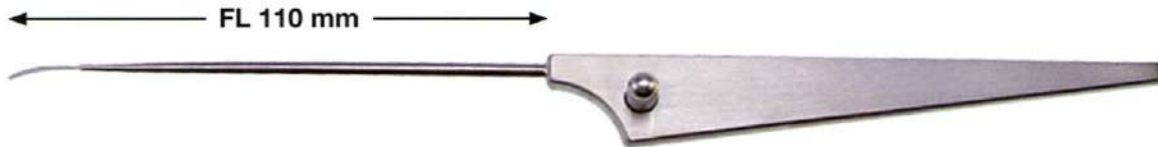

Art.Nr.	Description	Size	Spez.
573-200-50	spoon; 30° curved; handle	3,0 mm	
573-200-55	banana-knife; smooth; handle		
573-200-57	banana-knife; serrated; handle		
573-200-60	hook-knife; handle	3,0 mm	
573-200-70	knife 45°; retrograde; toothed; handle		
573-200-75	sickle-knife; handle		
573-200-80	rosette-knife; handle	3,0 mm	
573-200-85	cartilage-file; fine; handle		
573-200-87	cartilage-file; rough; handle		

SURGICAL INSTRUMENTS

Instruments with **knurled handle**

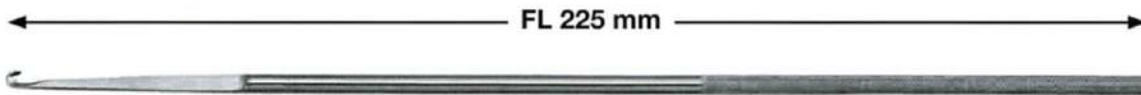

SURGICAL INSTRUMENTS

Art.Nr.	Description	Size	Spez.
573-150-10	meniscus hook-probe; graduated; handle		3,5 mm
573-150-15	meniscus hook-probe; handle	4,0 mm	
573-150-25	scalpel-knife; handle		
573-150-30	SMILLIE meniscotome; handle	3,0 mm	
573-150-35	SMILLIE meniscotome; handle	5,0 mm	
573-150-37	SMILLIE meniscotome; handle	7,0 mm	
573-150-40	ring-curette; 30° curved; handle	3,0 mm	

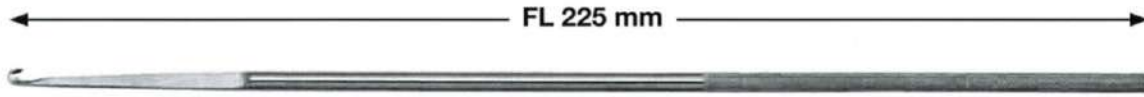

Art.Nr.	Description	Size	Spez.
573-150-50	spoon; 30° curved; handle	3,0 mm	
573-150-55	banana-knife; smooth; handle		
573-150-57	banana-knife; serrated; handle		
573-150-60	hook-knife; handle	3,0 mm	
573-150-70	knife 45°; retrograde; handle		
573-150-75	sickle-knife; handle		
573-150-80	rosette-knife; toothed; handle	3,0 mm	
573-150-85	cartilage-file; fine; handle		
573-150-87	cartilage-file; rough; handle		

SURGICAL INSTRUMENTS

Arthroscopic needle electrodes; **monopolar**;
Ø 4,0 mm; 90° angled



SURGICAL INSTRUMENTS

Art.Nr.	Description	Size	Spez.
283-035-04	needle electrode with handle; reusable; autoclavable 134°	Ø 0,6 x 1,5 mm; FL 115 mm	
283-040-04	needle electrode with handle; reusable; autoclavable 134°	Ø 0,6 x 4,0 mm; FL 115 mm	
283-050-04	button electrode with handle; reusable; autoclavable 134°	Ø 1,5 x 4,0 mm; FL 115 mm	
283-060-04	needle electrode with handle; reusable; autoclavable 134°	Ø 0,6 x 1,5 mm; FL 170 mm	
283-065-04	needle electrode with handle; reusable; autoclavable 134°	Ø 0,6 x 4,0 mm; FL 170 mm	
283-075-04	button electrode with handle; reusable; autoclavable 134°	Ø 1,5 x 4,0 mm; FL 170 mm	

Arthroscopic knife electrodes; **monopolar**
 Ø 4,0 mm; 45° angled



Art.Nr.	Description	Size	Spez.
283-045-04	knife electrode 45° with handle; reusable; autoclavable 134°	4,0 mm	FL 115 mm

283-070-04	knife electrode 45° with handle; reusable; autoclavable 134°	4,0 mm	FL 170 mm
------------	---	--------	-----------

Arthroscopic ball electrodes; **monopolar**
 Ø 4,0 mm





Art.Nr.	Description	Size	Spez.
283-055-04	ball electrode with handle; reusable; autoclavable 134°	Ø 3,0 mm	FL 115 mm

283-080-04	ball electrode with handle; reusable; autoclavable 134°	Ø 3,0 mm	FL 170 mm
------------	--	----------	-----------

SURGICAL INSTRUMENTS

Rinsing cannulas

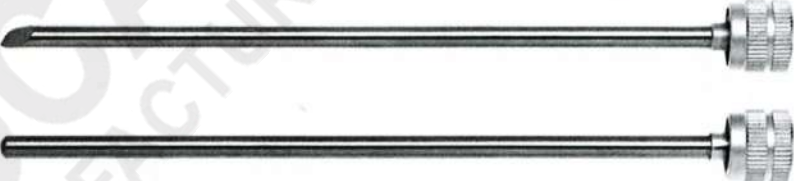
Art.Nr.	Description	Size	Spez.
579-260-00	set cannula for irrigation rinsing; with stopcock (only available as SET)	Ø 3,2 mm	FL 70 mm
	trocar; pyramidal		
	obturator; blunt		
579-270-00	set cannula for irrigation rinsing; with stopcock (only available as SET)	Ø 4,5 mm	FL 70 mm
	trocar; pyramidal		
	obturator; blunt		

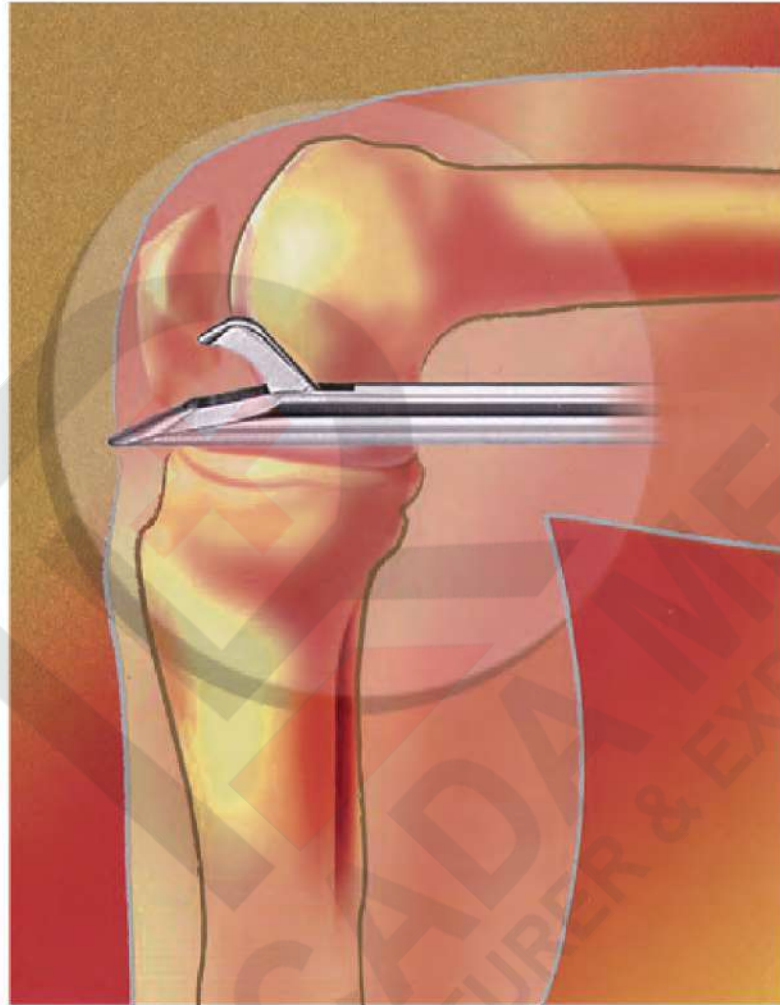

Arthroscopy

SURGICAL INSTRUMENTS

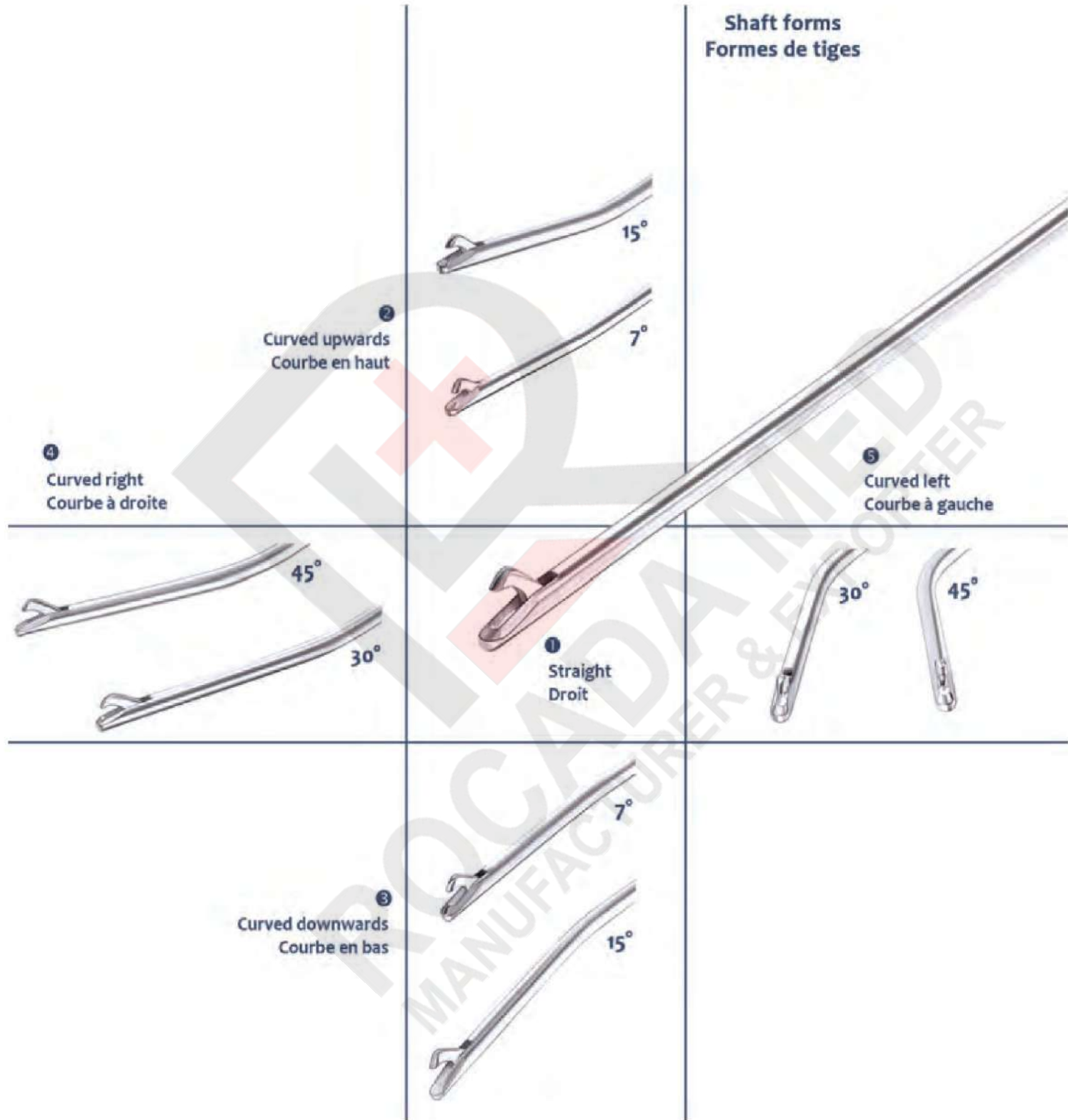

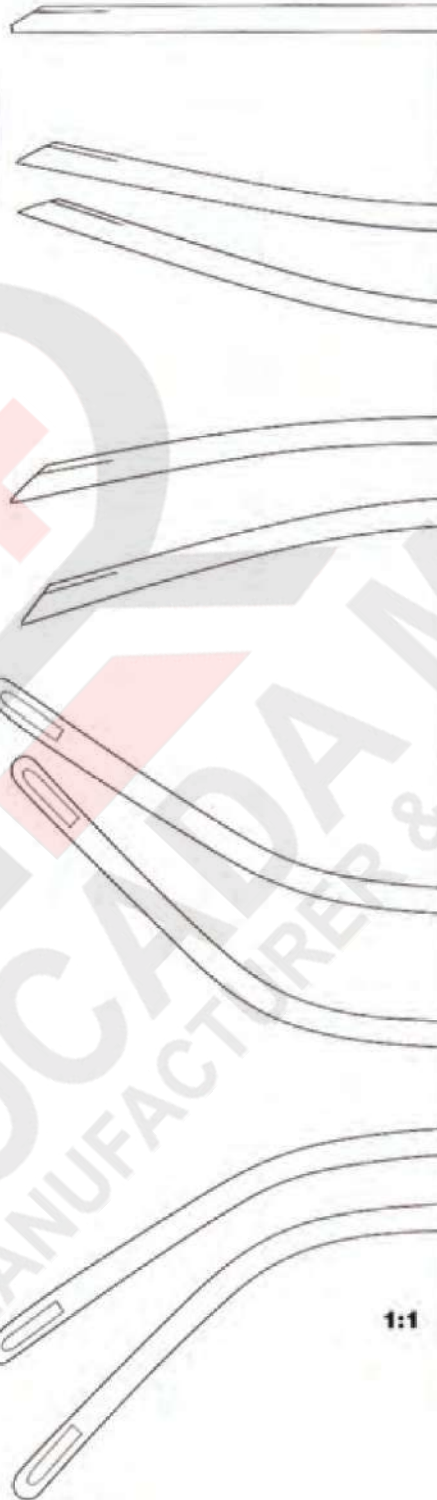

- ①
Straight
Droites
- ②
Curved upwards
Courbe en haut
- ③
Curved downwards
Courbe en bas
- ④
Curved right
Courbe à droite
- ⑤
Curved left
Courbe à gauche

1:1

We offers a comprehensive choice of Arthroscopy instruments for the joints of knee, shoulder, jaw and finger

Nous offrons un grand assortiment d'instruments pour l'arthroscopie de l'articulation du genou, épaule, maxillaire ou doigt.

SURGICAL INSTRUMENTS

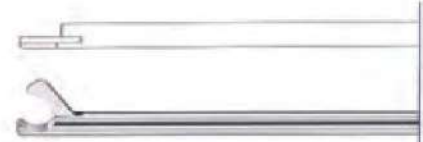
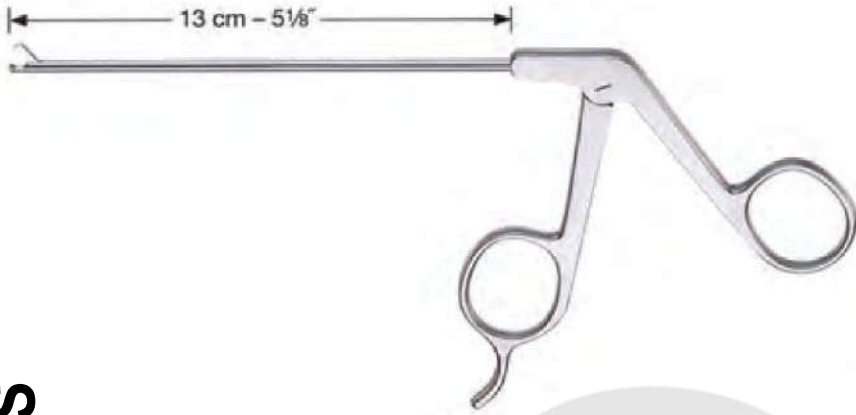

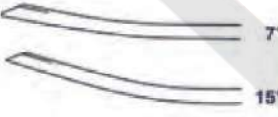
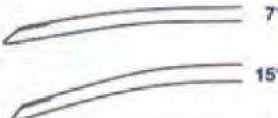
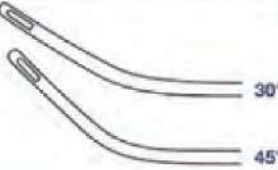
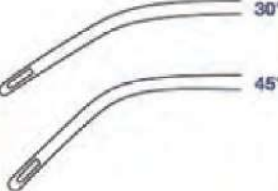
		∅ : 2,8 mm	∅ : 3,4 mm
	straight droit	77.88.27	77.88.35
	curved upwards courbe en haut	77.88.30	77.88.32
		77.88.47	77.88.55
	curved downwards courbe en bas	77.88.36	77.88.38
		77.88.40	77.88.42
	curved right courbe à droite	77.88.67	77.88.45
		77.88.44	77.88.46
	curved left courbe à gauche	77.88.87	77.88.95
		77.88.48	77.88.50

	without scoop sans pelle		with scoop avec pelle	
	1,2 mm 4 mm	1,8 mm 5 mm	1,2 mm 4 mm	1,8 mm 5 mm
	∅ 2,8 mm	∅ 3,4 mm	∅ 2,8 mm	∅ 3,4 mm
straight droit	77.85.02	77.84.35	77.85.27	77.85.05
curved upwards courbe en haut	77.85.07	77.84.37	77.85.17	77.85.19
	77.85.01	77.84.55	77.85.47	77.85.55
curved downwards courbe en bas	77.85.09	77.84.39	77.85.21	77.85.23
	77.85.11	77.84.41	77.85.25	77.85.29
curved right courbe à droite	77.85.04	77.84.75	77.85.67	77.85.75
	77.85.13	77.84.42	77.85.31	77.85.33
curved left courbe à gauche	77.85.03	77.84.95	77.85.87	77.85.95
	77.85.15	77.84.44	77.85.35	77.85.37

13 cm - 5 1/8"



15° angled upwards
15° coudées en haut

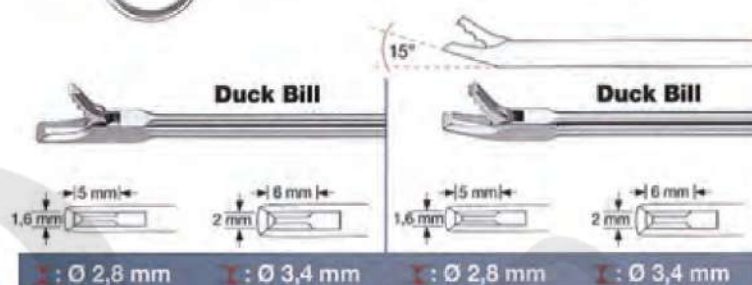

SURGICAL INSTRUMENTS

		Ø 2,8 mm	Ø 3,4 mm	Ø 2,8 mm	Ø 3,4 mm
	straight droit	77.89.27	77.89.35	77.89.21	77.89.23
	curved upwards courbe en haut	77.89.01	77.89.03	77.89.25	77.89.29
		77.89.47	77.89.55	77.89.31	77.89.33
	curved downwards courbe en bas	77.89.05	77.89.07	77.89.37	77.89.39
		77.89.09	77.89.11	77.89.41	77.89.43
	curved right courbe à droite	77.89.67	77.89.75	77.89.45	77.89.49
		77.89.13	77.89.15	77.89.54	77.89.57
	curved left courbe à gauche	77.89.87	77.89.95	77.89.51	77.89.53
		77.89.17	77.89.19	77.89.59	77.89.61

15° angled upwards
15° coudées en haut

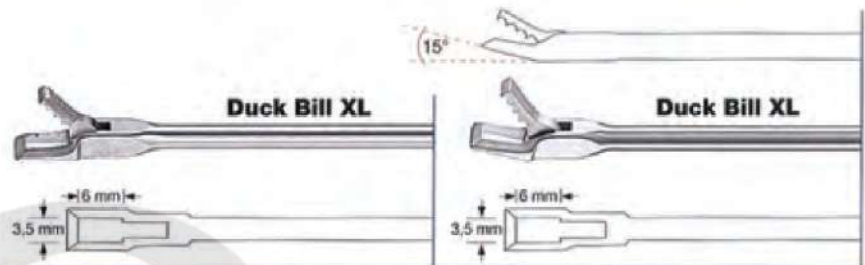

	\varnothing : 3,4 mm	\varnothing : 3,4 mm
straight droit	77.95.35	77.96.35
curved upwards courbe en haut	77.95.40	77.96.40
	77.95.55	77.96.55
curved downwards courbe en bas	77.95.42	77.96.42
	77.95.44	77.96.44
curved right courbe à droite	77.95.75	77.96.75
	77.95.65	77.96.65
curved left courbe à gauche	77.95.95	77.96.95
	77.95.85	77.96.85

SURGICAL INSTRUMENTS



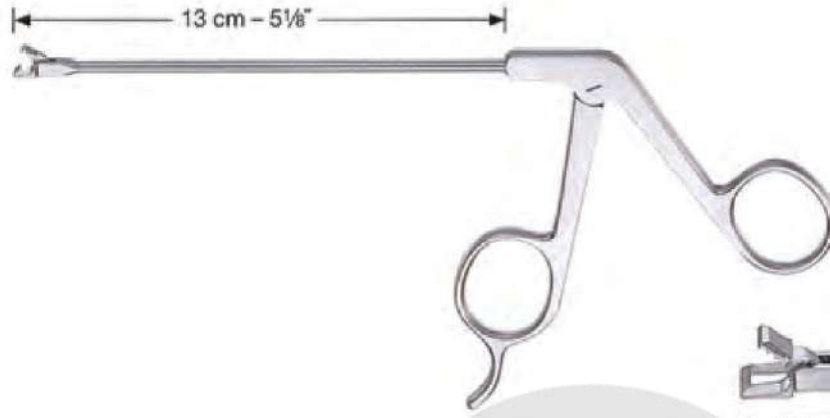



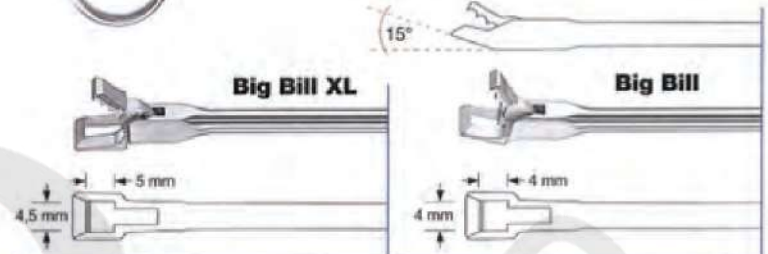

SURGICAL INSTRUMENTS



13 cm - 5 1/8"

15° angled upwards
15° coudées en haut



		Big Bill XL	Big Bill
		∅ 3,4 mm	∅ 3,4 mm
	straight droit	77.94.35	77.93.35
	curved upwards courbe en haut	77.94.40	77.93.40
		77.94.55	77.93.55
	curved downwards courbe en bas	77.94.42	77.93.42
		77.94.44	77.93.44
	curved right courbe à droite	77.94.75	77.93.75
		77.94.65	77.93.65
	curved left courbe à gauche	77.94.95	77.93.95
		77.94.85	77.93.85

	right droite	left gauche
	Big Bill	Big Bill
	∅ 3,4 mm	∅ 3,4 mm
straight droit	77.90.35	77.91.35
curved upwards courbe en haut	77.90.40	77.91.40
	77.90.55	77.91.55
curved downwards courbe en bas	77.90.42	77.91.42
	77.90.44	77.91.44
curved right courbe à droite	77.90.75	77.91.75
	77.90.65	77.91.65
curved left courbe à gauche	77.90.95	77.91.95
	77.90.85	77.91.85

SURGICAL INSTRUMENTS

SURGICAL INSTRUMENTS

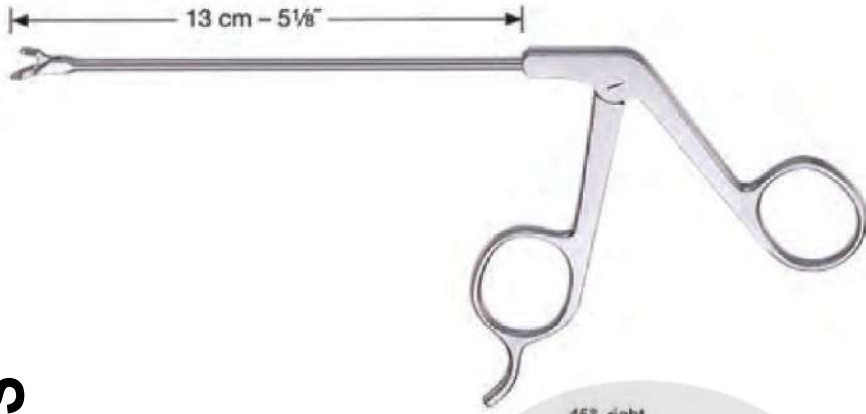

	<p>45°, right 45°, droite</p> <p>∅ : Ø 3,4 mm</p>	<p>45°, left 45°, gauche</p> <p>∅ : Ø 3,4 mm</p>
<p>straight, with scoop droites, avec pelle</p>	<p>77.95.01</p>	<p>77.95.05</p>
	<p>45°, right 45°, droite</p> <p>∅ : Ø 3,4 mm</p>	<p>45°, left 45°, gauche</p> <p>∅ : Ø 3,4 mm</p>
<p>straight, without scoop droites, sans pelle</p>	<p>77.95.03</p>	<p>77.95.07</p>

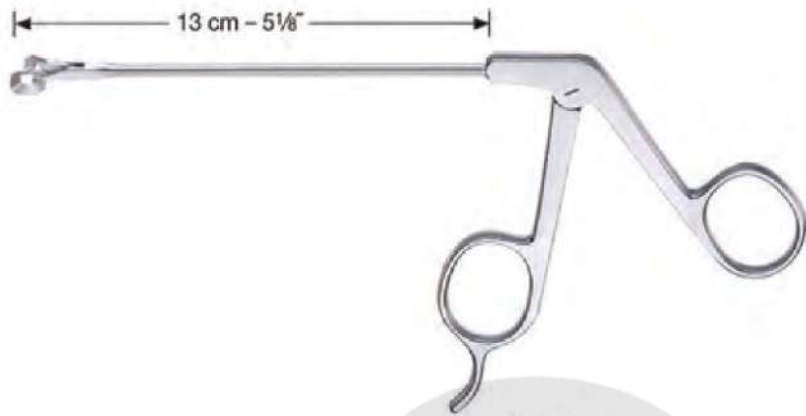

	<p>90°, right 90°, droite</p> <p>1,6 mm 5 mm</p> <p>∅ : 3,4 mm</p>	<p>90°, left 90°, gauche</p> <p>1,6 mm 5 mm</p> <p>∅ : 3,4 mm</p>
<p>straight, with scoop droites, avec pelle</p>	<p>77.95.09</p>	<p>77.95.13</p>
	<p>90°, right 90°, droite</p> <p>1,6 mm 5 mm</p> <p>∅ : 3,4 mm</p>	<p>90°, left 90°, gauche</p> <p>1,6 mm 5 mm</p> <p>∅ : 3,4 mm</p>
<p>straight, without scoop droites, sans pelle</p>	<p>77.95.11</p>	<p>77.95.15</p>

SURGICAL INSTRUMENTS

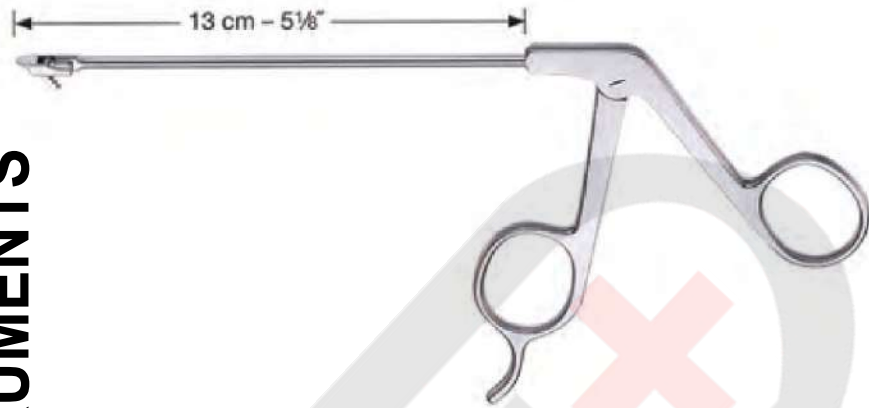

retrograde cutting, right
coupant en arrière, à droite

retrograde cutting, left
coupant en arrière, à gauche

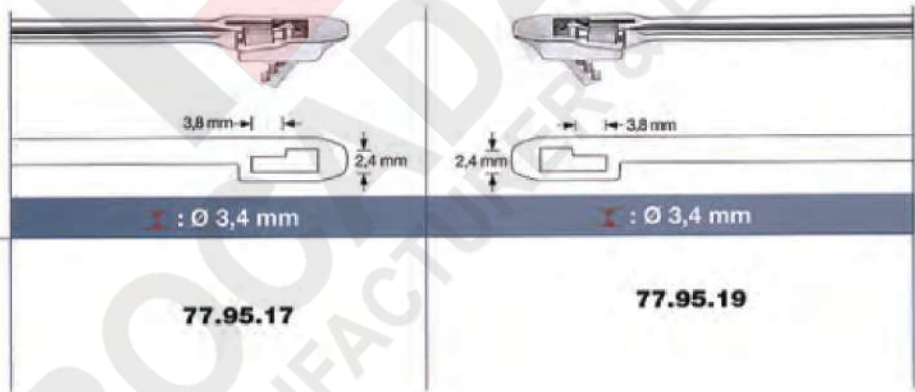

straight
droites

13 cm - 5 1/8"



1x2 teeth
1x2 dents

Alligator

	Ø 2,8 mm	Ø 3,4 mm	Ø 2,8 mm	Ø 3,4 mm
straight droites	77.91.13	77.91.12	77.91.46	77.91.45
	77.91.18	77.91.17	77.91.51	77.91.50

Biopsy forceps
Pincés pour biopsie

Biopsy forceps
Pincés pour biopsie

	Ø 2,8 mm	Ø 3,4 mm	Ø 2,8 mm	Ø 3,4 mm
straight droites	77.91.57	77.91.56	77.91.69	77.91.70
	77.91.61	77.91.60		



Shaft diameter
Tige diamètre



SURGICAL INSTRUMENTS

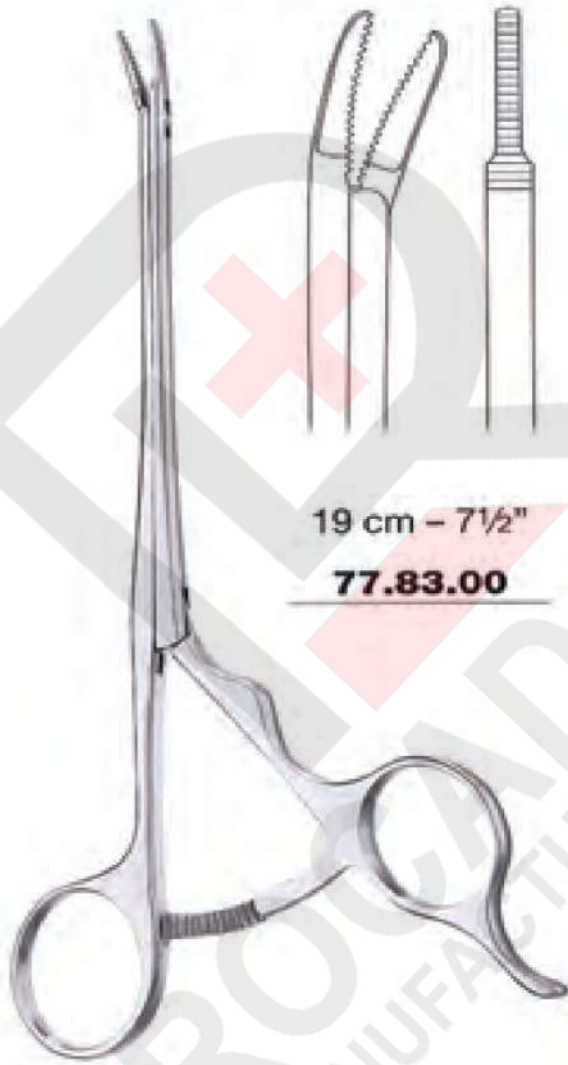

19 cm - 7 1/2"

77.83.00

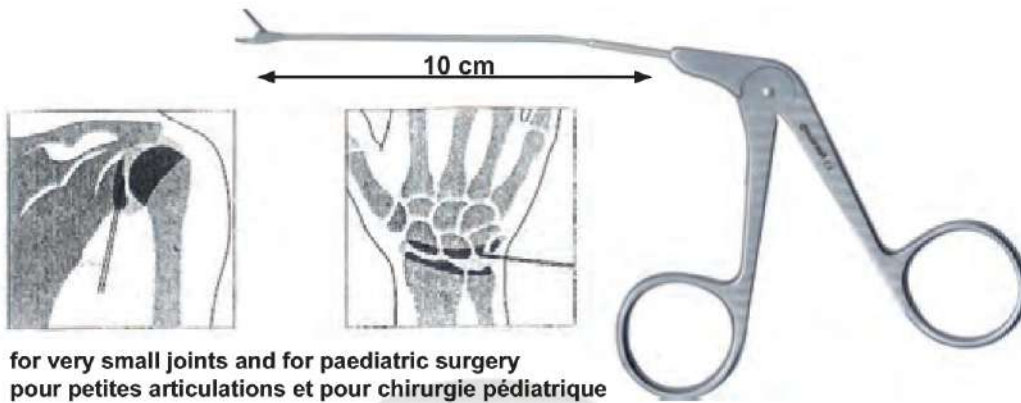

A.80.450

Mini-Basket Forceps for incising of fibro-cartilage
Pince à petit panier pour débridement du fibro-cartilage



A.80.529

Mini-Scissors downward cutting to facilitate the cutting of the synovium
Mini-ciseaux angulés vers le bas pour faciliter la coupe du synovium



A.80.550

Mini-Biopsy Forceps to obtain specimen of tissue
Mini-pince à biopsie pour obtenir un échantillon de tissu



A.80.555

Mini-Grasping Forceps to remove loose particles or larger pieces of fibro-cartilage or bone particles
Mini-pince à préhension pour enlever les particules libres ou de plus gros morceaux de fibro-cartilage ou particules d'os



A.80.560

Mini-Biopsy Forceps, serrated cup to remove loose particles or larger pieces of fibro-cartilage or bone particles
Mini-pince à biopsie, à mors striés pour enlever les particules libres ou de plus gros morceaux de fibro-cartilage ou particules d'os

Arthroscopy-Instruments with anatomically designed handle and overload protection
Instruments d'arthroscopie avec manche conçu anatomiquement et protection de surcharge

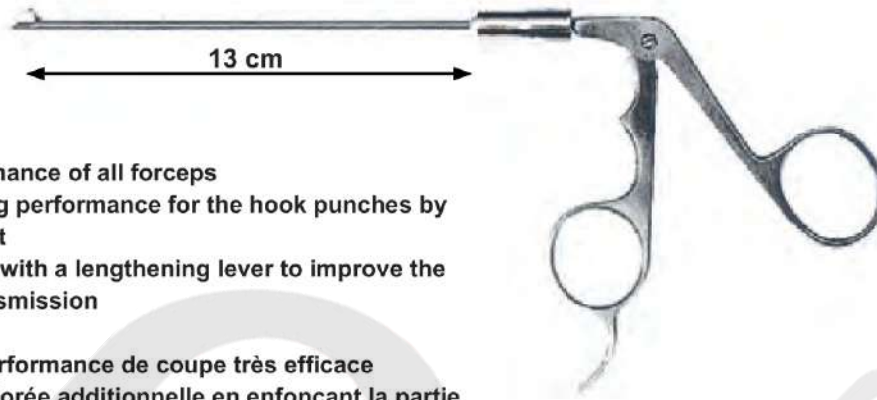

- very efficient cutting performance of all forceps
- additionally improved cutting performance for the hook punches by caving the moveable jaw part
- ergonomic designed handle with a lengthening lever to improve the handling and the power transmission
- toutes les pinces ont une performance de coupe très efficace
- performance de coupe améliorée additionnelle en enfonçant la partie du mors amovible des poinçons du crochet
- manche ergonomique avec levier en longueur pour améliorer la préhension et la puissance de transmission

Grasping forceps Pince à préhension		Ø 2,7 mm	A.93.430
		Ø 3,4 mm	A.93.480
		Ø 4,5 mm	A.93.530
Grasping forceps with ratchet Pince à préhension avec crémaillère		Ø 2,7 mm	A.93.436
		Ø 3,4 mm	A.93.486
		Ø 4,5 mm	A.93.536
Hook scissors Pince-ciseaux		Ø 2,7 mm	A.93.424
		Ø 3,4 mm	A.93.474
		Ø 4,5 mm	A.93.524
Hook punch, mini jaw Pince, forme crochet, mini-mors		Ø 2,7 mm	A.93.418
		Ø 3,4 mm	A.93.468
		Ø 4,5 mm	A.93.518

SURGICAL INSTRUMENTS

Arthroscopy-Instruments with anatomically designed handle and overload protection
 Instruments d'arthroscopie avec manche conçu anatomiquement et protection de surcharge

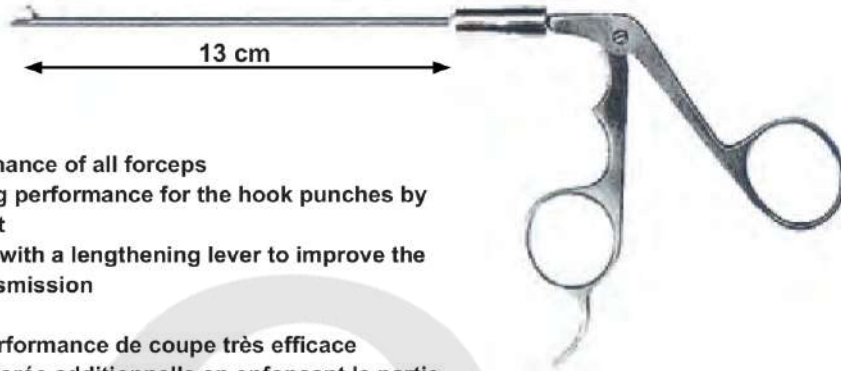

- very efficient cutting performance of all forceps
- additionally improved cutting performance for the hook punches by caving the moveable jaw part
- ergonomic designed handle with a lengthening lever to improve the handling and the power transmission

- toutes les pinces ont une performance de coupe très efficace
- performance de coupe améliorée additionnelle en enfonçant la partie du mors amovible des poinçons du crochet
- manche ergonomique avec levier en longueur pour améliorer la préhension et la puissance de transmission

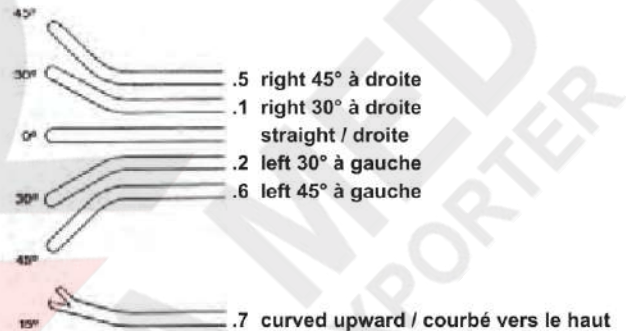

Square Punch
Pince, forme carré



Hook punch with Scoop
Pince, forme crochet



Basket Punch
Pince, forme corbeille



Hook Punch
Pince, forme crochet





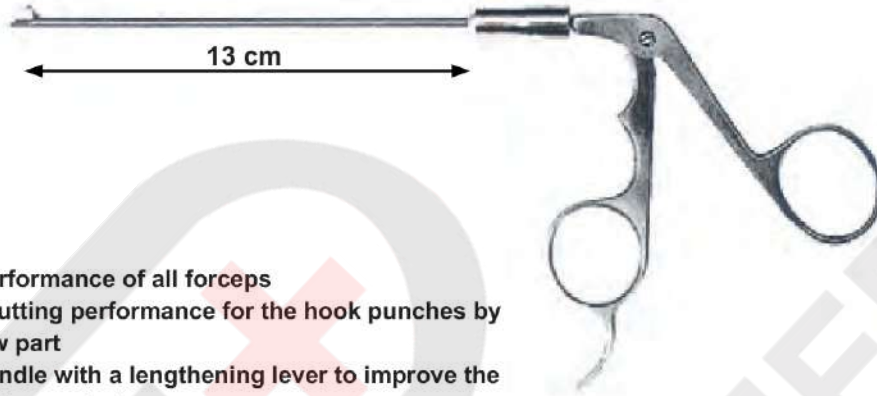

Arthroscopy-Instruments with anatomically designed handle and overload protection
Instruments d'arthroscopie avec manche conçu anatomiquement et protection de surcharge



- very efficient cutting performance of all forceps
- additionally improved cutting performance for the hook punches by caving the moveable jaw part
- ergonomic designed handle with a lengthening lever to improve the handling and the power transmission

- toutes les pinces ont une performance de coupe très efficace
- performance de coupe améliorée additionnelle en enfonçant la partie du mors amovible des poinçons du crochet
- manche ergonomique avec levier en longueur pour améliorer la préhension et la puissance de transmission

SURGICAL INSTRUMENTS

		"Duckbill" Punch Pince "Duckbill"	
			
		straight droit	15° upward 15° vers le haut
straight droit	3.5	A.93.630	A.93.632
	3.5	A.93.630.1	A.93.632.1
	3.5	A.93.630.2	A.93.632.2
15° upward 15° vers le haut	3.5	A.93.630.7	A.93.632.7